



G E N E R A L C A T A L O G U E



 **VERGNANO**

8 0 - E N

w w w . v e r g n a n o . c o m



Index

INTRODUCTION	2
New Products Catalogue Nr. 80	6
Product Range	8
Guide to Tap Application Table	10
Guide to Tap Datasheets	11
Guide to Thread Mills Datasheets	12
Guide to Tapping Attachments Datasheets	13
Tap Application Table	14
"A" SERIES - TAPS FOR GENERIC APPLICATIONS	
M ISO Metric coarse thread - DIN 13	34
EG-M ISO Metric coarse thread (for wire inserts) - DIN 8140-2	76
MF ISO Metric fine thread - DIN 13	78
UNC Unified coarse thread - ASME B1.1	101
UNF Unified fine thread - ASME B1.1	109
8-UN Unified constant pitch series thread - ASME B1.1	117
G Gas Whitworth thread - EN ISO 228	119
Rp Rp thread (BSPP) - DIN EN 10226-1	127
Rc Conical gas thread (BSPT), taper 1:16 - BS 21 and DIN EN 10226-2	128
BSW Whitworth thread - BS 84	129
NPT National pipe thread, taper 1:16 - ASME/ANSI B1.20.1	132
NPTF Dryseal National pipe thread, taper 1:16 - ASME/ANSI B1.20.3	134
"P" SERIES - HIGH PERFORMANCE TAPS	
M ISO Metric coarse thread - DIN 13	138
MF ISO Metric fine thread - DIN 13	158
UNC Unified coarse thread - ASME B1.1	171
UNF Unified fine thread - ASME B1.1	174
G Gas Whitworth thread - EN ISO 228	177
"S" SERIES - SYNCHRONOUS TAPS	
M ISO Metric coarse thread - DIN 13	186
MF ISO Metric fine thread - DIN 13	190
"H" SERIES - SOLID CARBIDE TAPS	
M ISO Metric coarse thread - DIN 13	194
MF ISO Metric fine thread - DIN 13	198
"F" SERIES - DIES	
M ISO Metric coarse thread - DIN 13	202
MF ISO Metric fine thread - DIN 13	203
UNC Unified coarse thread - ASME B1.1	206
UNF Unified fine thread - ASME B1.1	207
G Gas Whitworth thread - EN ISO 228	208
BSW Whitworth thread - BS 84	209
NPT National pipe thread, taper 1:16 - ASME/ANSI B1.20.1	219
"VR" SERIES - THREAD MILLS	
ISO Thread milles carbide	215
UN Thread milles carbide	218
GAS Thread milles carbide	221
"VA" SERIES - SYNCHRONOUS TAPPING ATTACHMENTS	
Synchronous Tapping Attachments	226
Accessories	230
TECHNICAL INFORMATION	233

ARTICLE LEGEND

A...	Taps for Generic Applications
P...	High Performance Taps
S...	Synchronous Taps
H...	Solid Carbide Taps
B...	Taps with internal coolant supply
... FC	Taps for blind holes
... FP	Taps for through holes
... S	Taps with increased relief
... L	Taps with long shank
... N	Forming taps with oil grooves
... R	Forming taps with internal coolant supply and radial outlet
... E	Taps with short chamfer (Form E)
... EG	Taps for wire thread inserts
... LH	Taps with left hand thread
... AZ	Taps with interrupted thread

SERIES

MATERIAL

CHAMFER FORM

TYPE OF HOLE

COATING

LUBRICATION

TAP MATERIAL

HSS	Conventional high speed steel
HSSE	Conventional high speed steel
HSSK	Powder metallurgy high speed steel
HSSZ	Powder metallurgy high speed steel
HSSP	Powder metallurgy high speed steel
HM	Solid Carbide

LUBRICATION

E	Emulsion
O	Oil
MQL	Minimum quantity lubrication

TAP APPLICATION TABLE LEGEND

A1 34 Product code / page

● 20-25 Ideal tap / cutting speed m/min

○ 15-20 Suitable tap / cutting speed m/min

M	4H
	6H/6HX
	6G/6GX
	7G/7GX
	6H+0,1
EG-M	6H MOD
MF	6H/6HX
	6G/6GX
UNC	2B/2BX
	3B
UNF	2B/2BX
	3B
8-UN	2B
G	ISO 5969/X
Rp(BSPP)	--
Rc(BSPT)	--
BSW	mc
NPT	--
NPTF	--

ISO513	Material	Group	Application	R. N/mm ²	Lubrication
P	Steel	P.1	Mild / magnetic steel	200 - 400	E, O, MQL
		P.2	Construction steel, case hardening steel	350 - 700	E, O, MQL
		P.3	Carbon steel	350 - 850	E, O, MQL
		P.4	Alloyed steel / tempered steel	500 - 850	E, O, MQL
		P.5	Alloyed steel / tempered steel	850 - 1200	E, O, MQL
		P.6	Alloyed steel / high strength steel	1200 - 1600	O
		P.7	Ferritic stainless steel, martensitic stainless steel, precipitation hardening	< 1000	E, O, MQL
M	Stainless steel	M.1	Austenitic stainless steel	< 850	E, O, MQL
		M.2	Ferritic+austenitic (Duplex)	< 1000	O, MQL
K	Cast iron	K.1	Grey cast iron	< 1000	E, O, MQL
		K.2	Nodular cast iron, malleable cast iron, tempered cast iron	< 1000	E, O, MQL
		K.3	Austempered ductile iron (ADI)	< 1400	O, MQL
N	Aluminium Aluminium alloys	N.1	Pure aluminium	< 300	E, O, MQL
		N.2	Aluminium wrought and die cast alloys with Si < 0,5% (long chipping)	< 500	E, O, MQL
		N.3	Aluminium wrought and die cast alloys with Si < 10% (medium chipping)	< 500	E, O, MQL
		N.4	Aluminium die cast alloys with Si > 10% (short chipping)	< 600	E, O, MQL
	Copper Copper alloys Brass Bronze	N.5	Pure copper	250 - 350	E, O, MQL
		N.6	Copper alloys (long chipping), soft brass	< 700	E, O, MQL
		N.7	Copper alloys (short chipping), hard brass	< 700	E, O, MQL
		N.8	High strength bronze	700 - 1500	O
	Magnesium Magnesium alloys	N.9	Pure magnesium, magnesium alloys	120 - 300	E, O, MQL
		N.10	High strength magnesium alloys	240 - 400	E, O, MQL
S	Titanium Titanium alloys	S.1	Pure titanium	400 - 600	E, O, MQL
		S.2	Titanium alloys	600 - 1000	O, MQL
	Nickel Nickel alloys	S.3	Pure nickel	400 - 600	E, O, MQL
		S.4	Nickel alloys	600 - 1000	O, MQL
H	Hardened materials	H.1	Alloyed steel, hardness HRC 44-55	-	O
		H.2	Alloyed steel, hardness HRC 56-63	-	O

G E N E R A L C A T A L O G U E



8 0 - E N

w w w . v e r g n a n o . c o m



About us

With more than 80 years of experience in the cutting tool industry, Vergnano is one of the world's leading manufacturers of high quality precision threading taps, hobs, end mills.

While keeping a firm foothold in the honoured tradition of the Vergnano brand, Vergnano has established itself internally and is renowned for quality, reliability, flexibility, innovation and commitment.



Strengths

Flexibility, readiness, quality

- Short decision-making processes.
- Rapid response times at all stages of the process.
- Flexibility in satisfying client requests for changes.
- Efficient and reliable technical support.
- Continuous employee training.
- Consistent product quality 100% guaranteed by qualified personnel.



Each manufacturing step takes place internally at the Vergnano production plant

Starting from the steel bar through to the final PVD coating process of the finished tool.

The quality of Vergnano tools is the consequence of strict controls of processes and products, constant research in new technical solutions and continuous investments in state-of-the-art technology.



Certifications



ISO 9001

Quality certificate

Thanks to the commitment on the research of high efficiency standards, Vergnano obtained ISO 9001 certification, according to UNI EN ISO 9001:2015.



ISO 14001

Sustainability certificate

Vergnano obtained Environmental Management System Certificate ISO 14001 putting Sustainability at the heart of its ethics.



Highlights

Expansion of high-performance cutting taps range for UNC and UNF threads:

- P19 / P20 for through holes
- P60 / P61 for deep blind holes
- Multilayer TiH1 coating
- Powder metallurgy steel for extended tool life



P SERIES



P SERIES



Expansion of high-performance cutting taps range for stainless steels:

- P151 for through holes for MF threads
- P170E for deep blind holes with short chamfer form E
- BP170 for deep blind holes with axial internal cooling
- P171 for deep blind holes for MF threads

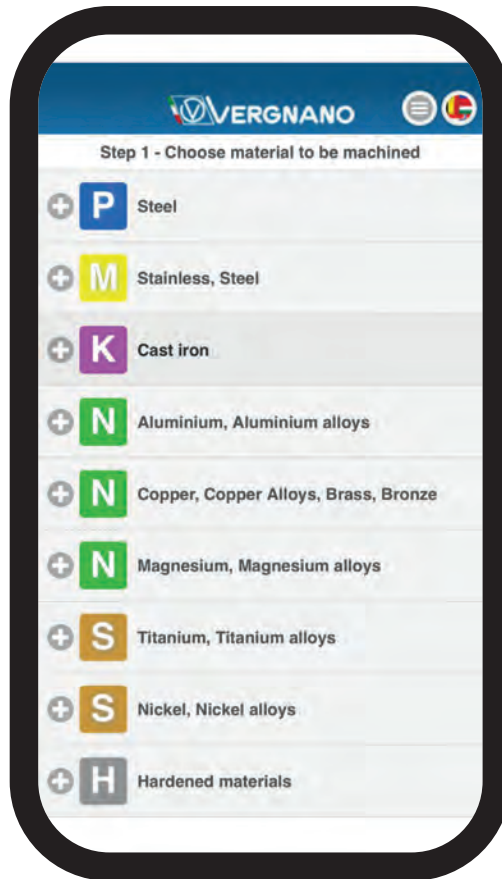

Exploit the full potential of Vergnano taps in a few simple steps

Search for best suited tool based on application data

Browse through tool technical specifications and cutting data for each search result



Download
TAppFinder
for iOS and Android



Programm overview

A



A SERIES

TAPS FOR GENERAL APPLICATIONS
The renowned Vergnano A-Series provides tapping solutions for almost all types of general applications.

P



P SERIES

TAPS FOR HIGH PERFORMANCE
P-Series comprises high performance taps for the highest demands in terms of productivity.

S



S SERIES

TAPS FOR SYNCHRONOUS TAPPING
S-Series are specifically designed for synchronous/rigid tapping and high speed machining.

H



H SERIES

SOLID CARBIDE TAPS
Solid carbide H Series taps offer extremely high productivity both in terms of tool life and cutting speeds.

F



F SERIES

DIES FOR GENERAL APPLICATIONS

F Series dies provide solutions for machining external threads in almost all types of general applications.

VR



VR SERIES

SOLID CARBIDE THREAD MILLS

Solid carbide thread mills for high productivity demands and optimal quality-price ratio.

VA



VA SERIES

MODULAR TAPPING ATTACHMENTS

VA Series modular tapping attachments offer good flexibility on synchronous tapping applications.

CONSULTATION GUIDE

Tap application table

ARTICLE LEGEND

- A... Taps for Generic Applications
- P... High Performance Taps
- S... Synchronous Taps
- H... Solid Carbide Taps
- B... Taps with internal coolant supply

- ... FC Taps for blind holes
- ... FP Taps for through holes
- ... S Taps with increased relief
- ... L Taps with long shank
- ... N Forming taps with oil grooves
- ... R Forming taps with internal coolant supply
- ... E Taps with short chamfer (Form E)
- ... EG Taps for wire thread inserts
- ... LH Taps with left hand thread
- ... AZ Taps with interrupted thread

TAP MATERIAL

- HSS Conventional high speed steel
- HSSE Conventional high speed steel
- HSSK Powder metallurgy high speed steel
- HSSZ Powder metallurgy high speed steel
- HSSP Powder metallurgy high speed steel
- HM Solid Carbide

LUBRICATION

- E Emulsion
- O Oil
- MQL Minimum quantity lubrication

TAP APPLICATION TABLE LEGEND

- A1 34 Product code / page
- 20-25 Ideal tap / cutting speed m/min
- 15-20 Suitable tap / cutting speed m/min

ISO 513	Material	Group			
P	Steel	P.1	Mild / magnetic steel		
		P.2	Construction steel, ca		
		P.3	Carbon steel		
		P.4	Alloyed steel / temper		
		P.5	Alloyed steel / temper		
		P.6	Alloyed steel / high st		
		P.7	Ferritic stainless steel		
M	Stainless steel	M.1	Austenitic stainless s		
		M.2	Ferritic-austenitic (D		
K	Cast iron	K.1	Grey cast iron		
		K.2	Nodular cast iron, ma		
		K.3	Austempered ductile		
N	Aluminium Aluminium alloys	N.1	Pure aluminium		
		N.2	Aluminium wrought an		
		N.3	Aluminium wrought an		
		N.4	Aluminium die cast al		
	N	Copper Copper alloys	N.5	Pure copper	
			N.6	Copper alloys (long ch	
			N.7	Copper alloys (short c	
		N	Brass Bronze	N.8	High strength bronze
				N.9	Pure magnesium, ma
				N.10	High strength magne
S	Titanium Titanium alloys	S.1	Pure titanium		
		S.2	Titanium alloys		
	S	Nickel Nickel alloys	S.3	Pure nickel	
			S.4	Nickel alloys	
H	Hardened materials	H.1	Alloyed steel, hardne		
		H.2	Alloyed steel, hardne		

*For specific material examples see "Technical Information" section o

TAP APPLICA

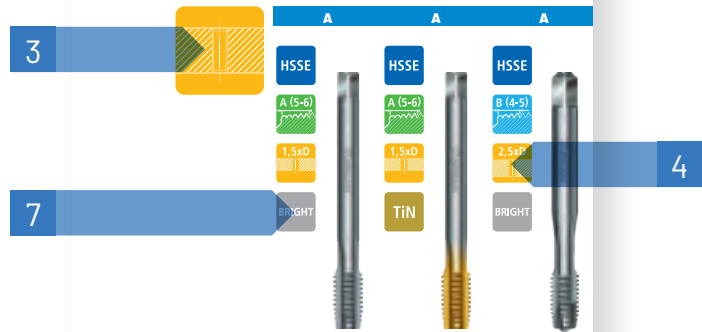

		4H			A15 S	47
6	M	6H/6HX			A15 S	45
		6G/6GX			A15 S	48
		7G/7GX			A15 S	49
		6H +0,1				
EG-M		6H MOD			A17 S	86
		6H/6HX			A17 S	90
MF		6G/6GX			A19 S	104
		2B/2BX	A27 FP	102	A27 FP	102
UNC		3B			A20 S	112
		2B/2BX	A28 FP	110	A28 FP	110
UNF		3B			A19 S	104
		2B/2BX	A28 FP	110	A28 FP	110
8-UN		2B			A119	117
		2B			A18 S	122
5	G	ISO 5969/X	A26 FP	120		
		Rp (BSPP)	--			
		Rc (BSPT)	--			
		BSW	mc	A24 FP	130	
		NPT	--			
		NPTF	--			
		ISO 513	Group			
P	P	P.1	○ 12-15	● 20-25	○ 18-20	
		P.2	● 10-12	● 15-20	● 20-25	
		P.3	● 8-10	● 12-15	● 15-20	
		P.4			● 12-15	
		P.5			○ 3-5	
		P.6				
		P.7			○ 5-7	
M	M	M.1			○ 5-7	
		M.2			○ 2-3	
K	K	K.1				
		K.2	● 8-10	● 12-15	● 15-20	
		K.3				
N	N	N.1	○ 12-15	● 20-25	○ 18-20	
		N.2	○ 10-12	○ 15-20	● 20-25	
		N.3	○ 10-12	○ 15-20	● 20-25	
		N.4				
		N.5	○ 10-12	● 15-20	○ 15-18	
		N.6	○ 8-10	○ 12-15	● 15-18	
		N.7				
		N.8				
		N.9				
		N.10				
S	S	S.1			○ 8-10	
		S.2				
		S.3			○ 8-10	
		S.4				
H	H	H.1				
		H.2				

In order to select the correct tap, follow steps 1 to 9.

- 1 Material
- 2 Material subgroup
- 3 Hole type
- 4 Thread depth
- 5 Thread type
- 6 Tolerance
- 7 Coating
- 8 Tool code (page)
- 9 Cutting parameters

CONSULTATION GUIDE

Tap datasheet

1

MF

DIN 13 HIGH PERFORMANCE MACHINE TAPS for blind and through holes
Straight flutes / for cast iron

15

2

HSSP

P45 V-MAXX **BP45** V-MAXX **P45 E** V-MAXX **BP45 E** V-MAXX

14

3

DIN 374

13

4

APPLICATION RANGE - CUTTING SPEED m/min

ISO	MG	P45 V-MAXX	BP45 V-MAXX	P45 E V-MAXX	BP45 E V-MAXX
K	K.1	• 40-50	• 40-50	• 40-50	• 40-50
	N.4	• 40-50	• 40-50	• 40-50	• 40-50
N	N.7	• 40-50	• 40-50	• 40-50	• 40-50
	N.9-10	• 45-55	• 45-55	• 45-55	• 45-55

12

5

ISO	MG	P45 V-MAXX	BP45 V-MAXX	P45 E V-MAXX	BP45 E V-MAXX
K	K.1	• 40-50	• 40-50	• 40-50	• 40-50
	N.4	• 40-50	• 40-50	• 40-50	• 40-50
N	N.7	• 40-50	• 40-50	• 40-50	• 40-50
	N.9-10	• 45-55	• 45-55	• 45-55	• 45-55

11

6

ISO	MG	P45 V-MAXX	BP45 V-MAXX	P45 E V-MAXX	BP45 E V-MAXX
K	K.1	• 40-50	• 40-50	• 40-50	• 40-50
	N.4	• 40-50	• 40-50	• 40-50	• 40-50
N	N.7	• 40-50	• 40-50	• 40-50	• 40-50
	N.9-10	• 45-55	• 45-55	• 45-55	• 45-55

10

7

€ P.47

9

8

Ød ₁	P	L ₁ js16	L ₂	L ₃	Ød ₂ h9	a h12	z	z	P45 V-MAXX ...0455A1AV0	BP45 V-MAXX ...0455M1AV0	P45 E V-MAXX ...0455A3AV0	BP45 E V-MAXX ...0455M3AV0
M8	1	90	16	-	6	4,9	4	7	A08100...	A08100...	A08100...	A08100...
10	1	90	18	-	7	5,5	4	9	A10100...	A10100...	A10100...	A10100...
10	1,25	100	18	-	7	5,5	4	8,8	A10125...	A10125...	A10125...	A10125...
12	1,25	100	22	-	9	7	4	10,8	A12125...	A12125...	A12125...	A12125...
12	1,5	100	22	-	9	7	4	10,5	A12150...	A12150...	A12150...	A12150...
14	1,25	100	22	-	11	9	4	12,8	A14125...	A14125...	A14125...	A14125...
14	1,5	100	22	-	11	9	4	12,5	A14150...	A14150...	A14150...	A14150...
16	1,5	100	22	-	12	9	4	14,5	A16150...	A16150...	A16150...	A16150...
20	1,5	125	25	-	16	12	4	18,5	A20150...	A20150...	A20150...	A20150...

8

- 1 Thread type
- 2 Application characteristics
- 3 Dimensional standard
- 4 Recommended application range
- 5 Sizes
- 6 Order example
- 7 Price list page reference
- 8 Standard execution

- 9 Through coolant
- 10 Direction of cut
- 11 Hole type
- 12 Chamfer form
- 13 Tolerance
- 14 Coating
- 15 Tool code

CONSULTATION GUIDE

Thread mill datasheet

1

ISO
DIN 13

VERGNANO

SOLID CARBIDE THREAD MILLS
Spiral flutes

12

2

INT HM VR40 TIAN VR45 TIAN

11

3

11

4

APPLICATION RANGE

ISO	VR40 TIAN	VR45 TIAN
P	•	•
M	•	•
K	•	•
N	•	•
S	•	•

For cutting data see page 213

10

INT INT

2xD 3xD

RH RH

9

8

5

P	M	ØD ₂ h6 [mm]	ØD [mm]	z	L ₂ [mm]	L ₁ [mm]	VR40 TIAN	VR45 TIAN
0.3	M1.4	3	1.05	3	4	39		VR45010I0300400
0.35	M1.6	3	1.2	3	4.8	39		VR45012I0350400
0.4	M2	6	1.53	3	4.5	58	VR40015I0400400	
0.4	M2	3	1.53	3	6	39		VR45015I0400600
0.5	M3	6	2.37	3	6.5	58	VR40023I0500600	
0.5	M3	6	2.37	3	9.5	58		VR45023I0500900
0.5	M3	6	2.37	3	9.5	105		VR45023I050090L
0.7	M4	6	3.1	3	9	58	VR40031I0700900	
0.7	M4	6	3.1	3	12.5	58		VR45031I0701200
0.7	M4	6	3.1	3	12.5	105		VR45031I070120L
0.8	M5	6	3.8	3	12.5	58	VR40038I0801200	
0.8	M5	6	3.8	3	16	58		VR45038I0801600
0.8	M5	6	3.8	3	16	105		VR45038I080160L
1	M6	6	4.65	3	14	58	VR40046I1001400	
1	M6	6	4.65	3	20	58		VR45046I1002000
1	M6	6	4.65	3	20	105		VR45046I100200L
1.25	M8	6	5.95	3	18	58	VR40059I1251800	
1.25	M8	6	5.95	3	24	58		VR45060I1252400
1.5	M10	8	7.8	3	23	64	VR40078I1502300	
1.75	M12	10	9	3	26	73	VR40090I1752600	
2	M16	12	11.8	4	35	84	VR40118I2003500	

7

6

€ P.63

6

VR SERIES

- | | |
|-------------------------------|--------------------|
| 1 Thread type | 7 Tool code |
| 2 Application characteristics | 8 Direction of cut |
| 3 Technical Drawing | 9 Hole type |
| 4 Application range | 10 Thread |
| 5 Sizes | 11 Coating |
| 6 Price list page reference | 12 Tool code |

CONSULTATION GUIDE

Tapping attachment datasheet



SYNCHRONOUS ER TAPPING ATTACHMENT with QUICK-CHANGE TAP ADAPTOR
With internal through coolant capability (1)

1



DIN 69893 HSK A

2

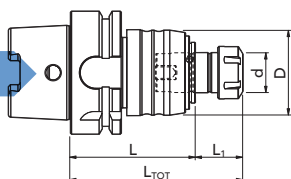

3

Article Code	Attachment	Tap Size	L	ø D	ø d	ER collet	L ₁	L _{TOT}
			[mm]	[mm]	[mm]		[mm]	[mm]
VA01A06302CH160	HSK-A63	M3 - M8	64	43	20	ER 16	20,5	84,5
VA01A06302CH250	HSK-A63	M6 - M20	97	60	32	ER 25	23,5	120,5
VA01A10002CH400	HSK-A100	M14 - M33	115	87	50	ER 40	28,5	143,5

4

SYNCHRONOUS ER TAPPING ATTACHMENT with QUICK-CHANGE TAP ADAPTOR
With internal through coolant capability (1)



DIN 1835 B+E

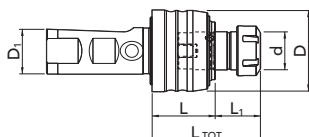

VA SERIES

Article Code	Attachment	Tap Size	L	ø D	ø d	ER collet	L ₁	L _{TOT}
	ø D ₁ [mm]		[mm]	[mm]	[mm]		[mm]	[mm]
VA01C02502CH160	25	M3 - M8	34	43	20	ER 16	20,5	54,5
VA01C02502CH250	25	M6 - M20	56	60	32	ER 25	23,5	79,5
VA01C04002CH400	40	M14 - M33	80	87	50	ER 40	28,5	108,5

(*) For coolant pressure above 50 bars a special nut screw is available on request

226| vergnano

€ P.66

6

- 1 Application characteristics
- 2 Technical Drawing
- 3 Size

- 4 Tool code
- 5 Price list page reference

TAP APPLICATION TABLE

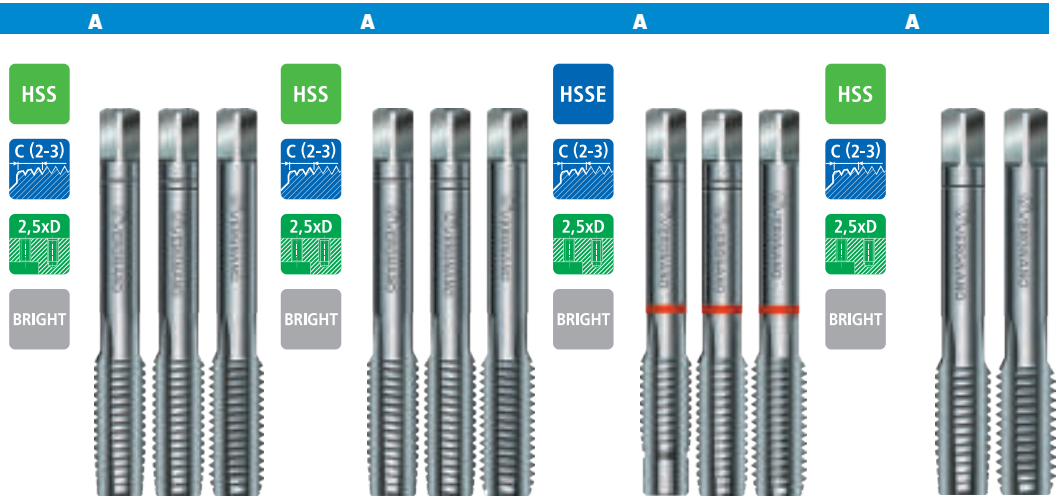

M	4H				
	6H/6HX	A1	34	A1LH	36
	6G/6GX				
	7G/7GX				
	6H+0,1				
EG-M	6H MOD				
MF	6H/6HX				A2 78
	6G/6GX				
UNC	2B/2BX	A7	101		
	3B				
UNF	2B/2BX				A8 109
	3B				
8-UN	2B				
G	ISO 5969/X				A5 119
Rp (BSPP)	--				
Rc (BSPT)	--				
BSW	mc	A4	129		
NPT	--				
NPTF	--				
ISO 513	Group				
P	P.1	●		●	
	P.2	●		●	
	P.3	●		●	
	P.4	●		●	
	P.5				●
	P.6				
	P.7	●		●	
M	M.1	○		○	
	M.2	○		○	
K	K.1	○		○	
	K.2	●		●	
	K.3				●
N	N.1	●		●	
	N.2	●		●	
	N.3	●		●	
	N.4	○		○	
	N.5	●		●	
	N.6	●		●	
	N.7	●		●	
	N.8				●
	N.9				
	N.10				●
S	S.1	○		○	
	S.2				○
	S.3	○		○	
	S.4				○
H	H.1				
	H.2				

TAP APPLICATION TABLE

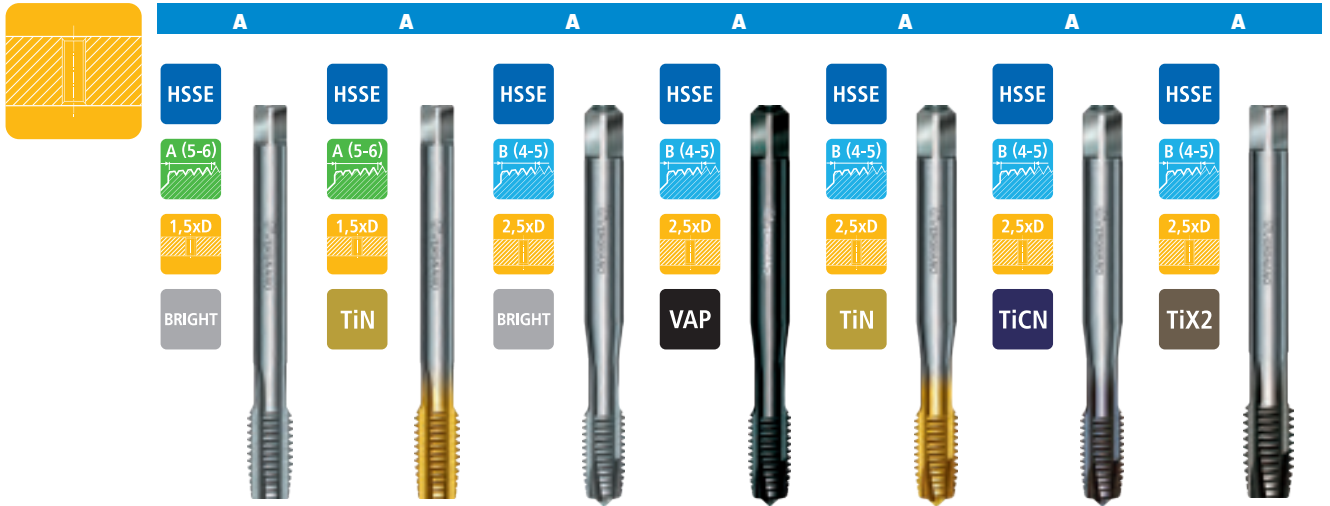

M	4H			A15 S	47			A15 S	47		
	6H/6HX			A15 S	45	A15 S	45	A15 S	45	A15 S	45
	6G/6GX			A15 S	48			A15 S	48		
	7G/7GX			A15 S	49			A15 S	49		
	6H +0,1										
EG-M	6H MOD										
MF	6H/6HX			A17 S	86	A17 S	86	A17 S	86	A17 S	86
	6G/6GX			A17 S	90			A17 S	90		
UNC	2B/2BX	A27 FP	102	A27 FP	102	A19 S	104		A19 S	104	A19 S
	3B			A19 S	104						
UNF	2B/2BX	A28 FP	110	A28 FP	110	A20 S	112		A20 S	112	A20 S
	3B			A20 S	112						
8-UN	2B			A119	117			A119	117		
G	ISO 5969/X	A26 FP	120			A18 S	122			A18 S	122
Rp(BSPP)	--										
Rc(BSPT)	--										
BSW	mc	A24 FP	130								
NPT	--										
NPTF	--										
ISO 513	Group										
P	P.1	○ 12-15	● 20-25	○ 18-20	○ 18-20	○ 30-35	○ 30-35				
	P.2	● 10-12	● 15-20	● 20-25	● 20-25	● 30-35	● 30-35				
	P.3	● 8-10	● 12-15	● 15-20	● 15-20	● 25-30	● 25-30				
	P.4			● 12-15	● 12-15	● 20-25	● 20-25				
	P.5			○ 3-5	○ 3-5	● 10-15	● 10-15				
	P.6										
	P.7						● 8-10	● 8-10	● 10-12		
M	M.1					● 8-10	● 8-10	● 10-12			
	M.2										
K	K.1										
	K.2	● 8-10	● 12-15	● 15-20	● 15-20	● 25-30	● 25-30				
	K.3										
N	N.1	○ 12-15	● 20-25	○ 18-20	○ 18-20	○ 30-35	○ 30-35				
	N.2	○ 10-12	○ 15-20	● 20-25	● 20-25	● 30-35	● 30-35				
	N.3	○ 10-12	○ 15-20	● 20-25	● 20-25	● 30-35	● 30-35				
	N.4										
	N.5	○ 10-12	● 15-20	○ 15-18	○ 15-18	○ 25-30	○ 25-30				
	N.6	○ 8-10	○ 12-15	● 15-18	● 15-18	● 25-30	● 25-30				
	N.7										
	N.8										
	N.9										
	N.10										
S	S.1			○ 8-10	○ 8-10						
	S.2										
	S.3			○ 8-10	○ 8-10	○ 12-15	○ 12-15				
	S.4										
H	H.1										
	H.2										

TAP APPLICATION TABLE

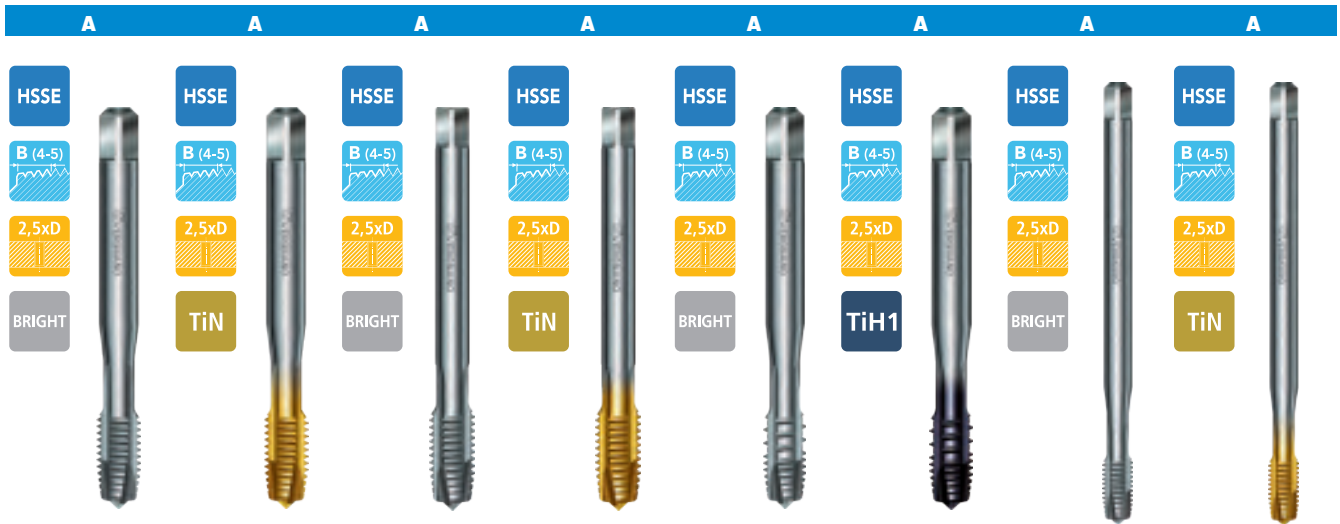

A		A		A		A		A		A		A			
A15 SLH	50	A15 SLH	50	A16 S	51	A16 S	51	A15 AZ	52	A15 AZ	52	A15 L	53	A15 L	53

○ 18-20	○ 30-35	○ 18-20	○ 30-35	● 18-20	● 30-35	● 18-20	● 30-35	● 18-20	● 30-35
● 20-25	● 30-35	● 20-25	● 30-35			● 15-18	● 25-30	● 15-18	● 25-30
● 15-20	● 25-30	● 15-20	● 25-30			● 12-15	● 20-25	○ 10-12	○ 15-20
● 12-15	● 20-25	● 12-15	● 20-25						
○ 3-5	● 10-15	○ 3-5	● 10-15						
	● 8-10		● 8-10						○ 6-8
	● 8-10		● 8-10						○ 6-8
● 15-20	● 25-30	● 15-20	● 25-30					○ 12-15	○ 20-25
○ 18-20	○ 30-35	○ 18-20	○ 30-35	● 18-20	● 30-40	● 18-20	○ 30-35		
● 20-25	● 30-35	● 20-25	● 30-35	● 15-18	● 30-40	● 15-18	● 25-30		
● 20-25	● 30-35	● 20-25	● 30-35			○ 15-18	○ 25-30		
○ 15-18	○ 25-30	○ 15-18	○ 25-30	● 15-18	● 30-35	● 15-18	○ 25-30		
● 15-18	● 25-30	● 15-18	● 25-30	● 12-15	● 30-35	● 12-15	● 20-25		
○ 8-10		○ 8-10		○ 6-8		○ 6-8			
○ 8-10	○ 12-15	○ 8-10	○ 12-15	○ 6-8		○ 8-10			

TAP APPLICATION TABLE

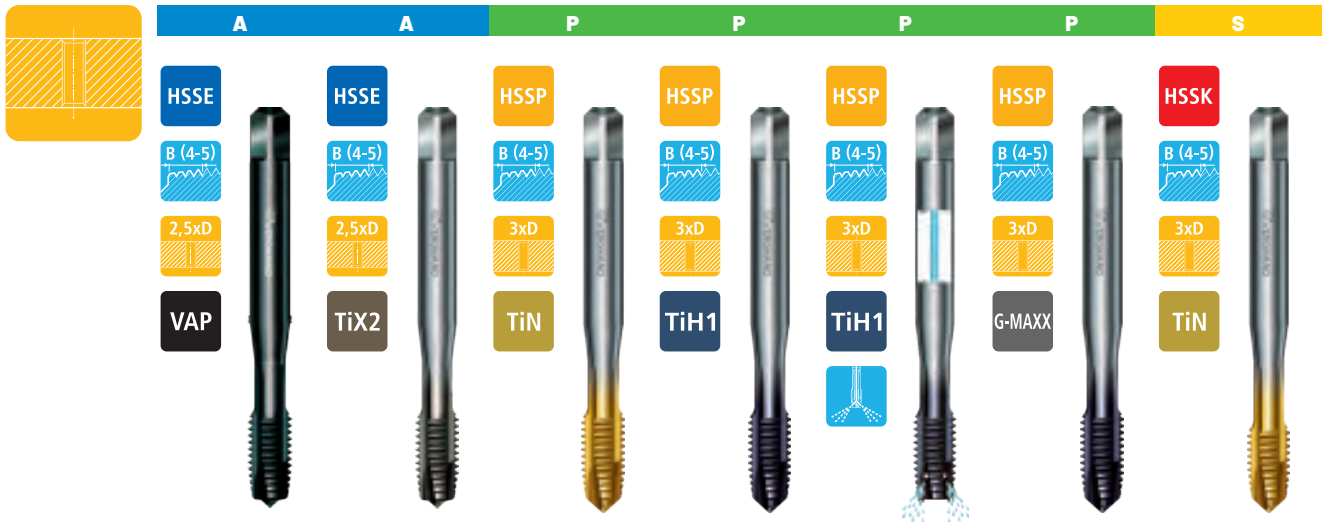

		A		A		P		P		P		P		S	
		Material	Coating	Material	Coating	Material	Coating	Material	Coating	Material	Coating	Material	Coating	Material	Coating
M	4H														
	6H/6HX	A150	54	A150	54	P15	140	P15	140	BP15	140	P150	141	S15	187
	6G/6GX							P15	140						
	7G/7GX														
6H+0,1															
EG-M	6H MOD														
MF	6H/6HX					P17	159	P17	174	BP17	159	P151	160	S17	191
	6G/6GX							P17	174						
UNC	2B/2BX							P19	171						
	3B														
UNF	2B/2BX							P20	175						
	3B														
8-UN	2B														
G	ISO 5969/X					P18	177	P18	177						
Rp(BSPP)	--														
Rc(BSPT)	--														
BSW	mc														
NPT	--														
NPTF	--														
ISO 513	Group														
P	P.1														● 50-60
	P.2					○ 30-40	○ 30-40	○ 30-40							● 50-60
	P.3					● 25-35	● 25-35	● 25-30							● 45-55
	P.4					● 20-30	● 20-30	● 20-30							● 40-50
	P.5					● 10-20	● 10-20	● 10-20							● 15-25
	P.6					● 8-10	● 8-10	● 8-10							
	P.7	● 10-12	● 10-15	● 10-15	● 10-15	● 10-15	● 10-15	● 10-15	● 10-15	● 15-20	● 15-25				
M	M.1	● 10-12	● 10-15	● 10-15	● 10-15	● 10-15	● 10-15	● 10-15	● 15-20	● 15-25					
	M.2		○ 8-10	● 6-8	● 6-8	● 6-8	● 6-8	● 6-8	● 10-12	● 10-20					
K	K.1														
	K.2					● 25-35	● 25-35	● 25-35						● 45-55	
	K.3														
N	N.1													● 50-60	
	N.2					● 30-40	● 30-40	● 30-40						● 45-55	
	N.3					● 30-40	● 30-40	● 30-40						● 45-55	
	N.4														
	N.5													● 40-50	
	N.6					● 25-30	● 25-30	● 25-30						● 35-45	
	N.7														
	N.8														
	N.9														
	N.10														
S	S.1														
	S.2							○ 12-18	○ 12-18						
	S.3													● 15-25	
	S.4					○ 12-18	○ 12-18	○ 12-18						○ 10-20	
H	H.1														
	H.2														

TAP APPLICATION TABLE

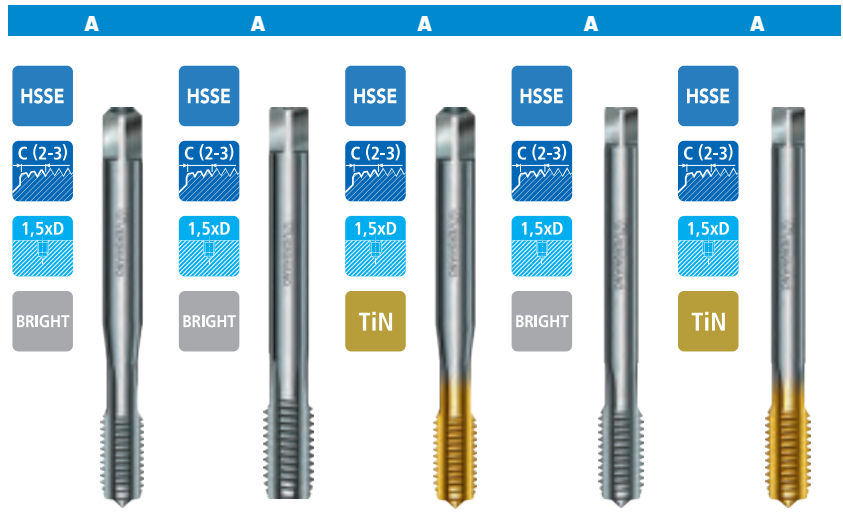
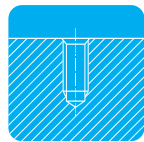

S15	187	BS15	187

A21 FC	38			A21 FC	38	A22 FC	40	A22 FC	40
A190	76								
A23 FC	82	A23 FC LH	82	A23 FC	82				
A27 FC	102			A27 FC	102				
A28 FC	110			A28 FC	110				
A26 FC	120								
A24 FC	130								

● 50-60	● 50-60
● 50-60	● 50-60
● 45-55	● 45-55
● 40-50	● 40-50
● 15-25	● 15-25
● 15-25	● 15-25
● 15-25	● 15-25
● 10-20	● 10-20
● 45-55	● 45-55
● 50-60	● 50-60
● 45-55	● 45-55
● 45-55	● 45-55
● 40-50	● 40-50
● 35-45	● 35-45
● 15-25	● 15-25
○ 10-20	○ 10-20
● 15-25	● 15-25
○ 10-20	○ 10-20

○ 12-15	○ 12-15	● 20-25	○ 12-15	● 20-25
● 10-12	● 10-12	● 15-20	● 10-12	● 15-20
● 8-10	● 8-10	● 12-15	● 8-10	● 12-15
● 8-10	● 8-10	● 12-15	● 8-10	● 12-15
○ 12-15	○ 12-15	● 20-25	○ 12-15	● 20-25
○ 10-12	○ 10-12	○ 15-20	○ 10-12	○ 15-20
○ 10-12	○ 10-12	○ 15-20	○ 10-12	○ 15-20
○ 10-12	○ 10-12	● 15-20	○ 10-12	● 15-20
○ 8-10	○ 8-10	○ 12-15	○ 8-10	○ 12-15

TAP APPLICATION TABLE

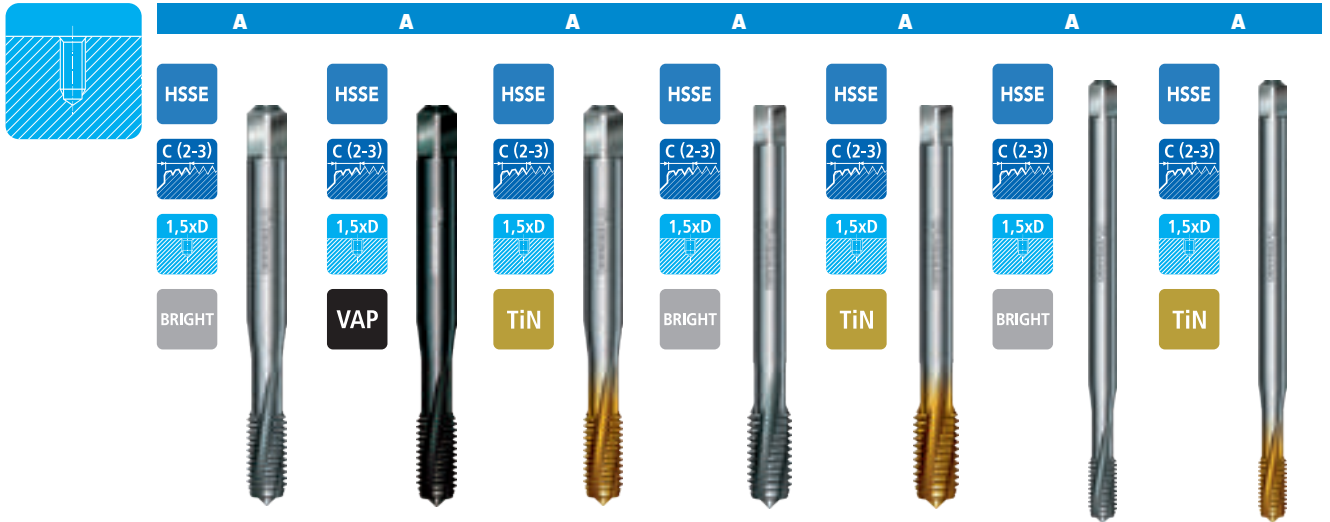

M	4H														
	6H/6HX	A29	55	A29	55	A29	55	A29 376	58	A29 376	58	A29 L	59	A29 L	59
	6G/6GX	A29	57			A29	57								
	7G/7GX														
	6H +0,1														
EG-M	6H MOD														
MF	6H/6HX	A30	91			A30	91								
	6G/6GX														
UNC	2B/2BX	A33	106			A33	106								
	3B	A33	106												
UNF	2B/2BX	A34	114			A34	114								
	3B	A34	114												
8-UN	2B														
G	ISO 5969/X	A32	123			A32	123								
Rp(BSPP)	--														
Rc(BSPT)	--														
BSW	mc	A31	131			A31	131								
NPT	--														
NPTF	--														
ISO 513	Group														
P	P.1	●	18-20	●	18-20	●	30-35	●	18-20	●	30-35	●	18-20	●	30-35
	P.2	●	15-18	●	15-18	●	25-30	●	15-18	●	25-30	●	15-18	●	25-30
	P.3	●	12-15	●	12-15	●	20-25	●	12-15	●	20-25	●	12-15	●	20-25
	P.4	●	10-12	●	10-12	●	15-20	●	10-12	●	15-20	●	10-12	●	15-20
	P.5					●	5-10			●	5-10			●	5-10
	P.6														
	P.7														
M	M.1														
	M.2														
K	K.1														
	K.2	●	12-15	●	12-15	●	20-25	●	12-15	●	20-25	●	12-15	●	20-25
	K.3														
N	N.1	●	18-20	●	18-20	○	30-35	●	18-20	○	30-35	●	18-20	○	30-35
	N.2	●	15-18	●	15-18	●	25-30	●	15-18	●	25-30	●	15-18	●	25-30
	N.3	●	15-18	●	15-18	●	25-30	●	15-18	●	25-30	●	15-18	●	25-30
	N.4														
	N.5	●	15-18	●	15-18	○	25-30	●	15-18	○	25-30	●	15-18	○	25-30
	N.6	●	12-15	●	12-15	●	20-25	●	12-15	●	20-25	●	12-15	●	20-25
	N.7														
	N.8														
	N.9														
	N.10														
S	S.1	○	6-8	○	6-8			○	6-8			○	6-8		
	S.2														
	S.3	○	6-8	○	6-8	○	8-10	○	6-8	○	8-10	○	6-8	○	8-10
	S.4														
H	H.1														
	H.2														

TAP APPLICATION TABLE

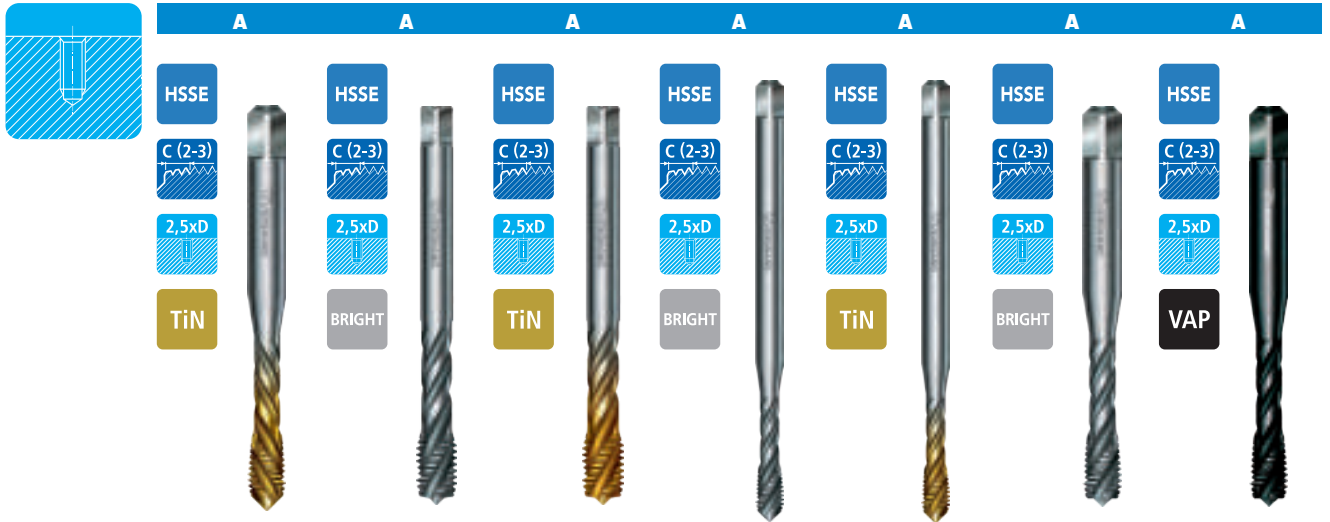

M	4H														
	6H/6HX	A70 SLH	66	A76 S	67	A76 S	67	A70 L	68	A70 L	68	A120	69	A120	69
	6G/6GX														
	7G/7GX														
	6H +0,1														
EG-M	6H MOD														
MF	6H/6HX														
	6G/6GX														
UNC	2B/2BX														
	3B														
UNF	2B/2BX														
	3B														
8-UN	2B														
G	ISO 5969/X														
Rp(BSPP)	--														
Rc(BSPT)	--														
BSW	mc														
NPT	--														
NPTF	--														
ISO 513	Group														
P	P.1							● 12-15		● 25-30		● 12-15		● 12-15	
	P.2	● 25-30		● 15-20		● 25-30		● 10-15		● 20-25		● 10-15		● 10-15	
	P.3	● 20-25		● 12-15		● 20-25	○ 8-10		○ 15-20		○ 8-10		○ 8-10		
	P.4	● 15-20		● 10-12		● 15-20									
	P.5	● 5-10		○ 6-8		● 5-10									
	P.6														
	P.7	● 6-8				● 6-8									
M	M.1	● 6-8				● 6-8									
	M.2														
K	K.1														
	K.2	● 20-25		● 12-15		● 20-25	○ 8-10		○ 15-20		○ 8-10		○ 8-10		
	K.3														
N	N.1							● 12-15		○ 25-30		● 12-15		● 12-15	
	N.2	○ 30-35		○ 18-20		○ 30-35		● 12-15		● 25-30		● 12-15		● 12-15	
	N.3	● 25-30		● 15-18		● 25-30	○ 10-12		○ 20-25		○ 10-12		○ 10-12		
	N.4														
	N.5							● 10-12		○ 20-25		● 10-12		● 10-12	
	N.6	● 25-30		● 15-18		● 25-30		● 10-12		● 20-25		● 10-12		● 10-12	
	N.7														
	N.8														
	N.9														
	N.10														
S	S.1			○ 6-8											
	S.2														
	S.3	○ 8-10		○ 6-8		○ 8-10									
	S.4														
H	H.1														
	H.2														

TAP APPLICATION TABLE



A120	69	A170	70	A170	70	A62	71	A62	71	A72	72	A72	72	P29	142
														P30	161
						A65	108								
						A66	116								

● 25-30								● 12-15	● 25-30						
● 20-25														● 15-18	
○ 15-20														● 12-15	
														● 8-10	
		● 6-8	● 8-10											● 3-5	
		● 6-8	● 8-10											● 8-10	
			○ 5-7												
○ 15-20														● 15-18	
○ 25-30						● 12-15	● 25-30	● 12-15	● 25-30						
● 25-30						● 12-15	● 25-30	● 12-15	● 25-30						
○ 20-25						○ 10-12	○ 20-25	● 10-12	● 20-25					● 15-18	
○ 20-25						● 10-12	● 20-25	● 10-12	● 20-25					● 15-18	
● 20-25						● 10-12	● 20-25	● 10-12	● 20-25					● 12-15	
						● 6-8	● 10-12								
						● 6-8	● 10-12							● 2-3	
														● 2-3	

TAP APPLICATION TABLE

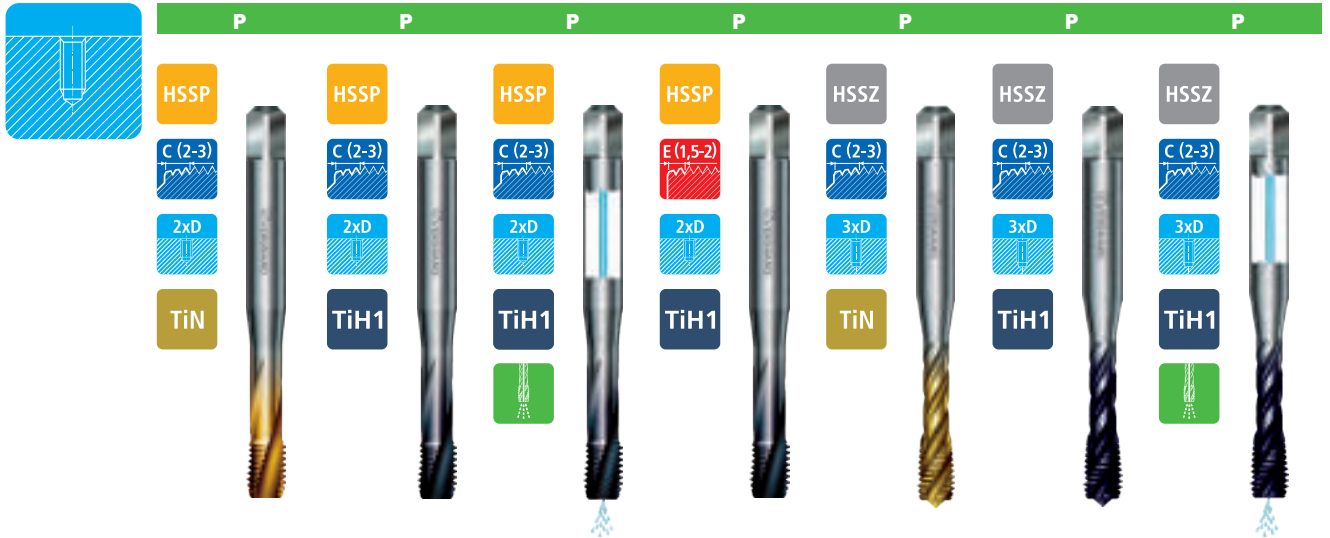

M	4H														
	6H/6HX	P29	142	P29	142	BP29	142	P29 E	143	P70	144	P70	144	BP70	145
	6G/6GX									P70	144				
	7G/7GX									P70	144				
	6H +0,1														
EG-M	6H MOD														
MF	6H/6HX	P30	161	P30	161	BP30	161	P30 E	162	P71	163	P71	163	BP71	163
	6G/6GX									P71	163				
UNC	2B/2BX									P60	172				
	3B														
UNF	2B/2BX									P61	175				
	3B														
8-UN	2B														
G	ISO 5969/X							P59	178	P59	178	BP59	178		
Rp(BSPP)	--														
Rc(BSPT)	--														
BSW	mc														
NPT	--														
NPTF	--														
ISO 513	Group														
P	P.1									○ 25-35	○ 25-35	○ 25-35			
	P.2														
	P.3	● 25-30	● 25-30	● 25-30	● 25-30	● 25-30	● 25-30	● 25-30	● 25-30	● 20-30	● 20-30	● 20-30	● 20-30	● 20-30	
	P.4	● 20-25	● 20-25	● 20-25	● 20-25	● 20-25	● 20-25	● 20-25	● 20-25	● 15-25	● 15-25	● 15-25	● 15-25	● 15-25	
	P.5	● 10-15	● 10-15	● 10-15	● 10-15	● 10-15	● 10-15	● 10-15	● 10-15	● 5-15	● 5-15	● 5-15	● 5-15	● 5-15	
	P.6	● 5-10	● 5-10	● 5-10	● 5-10	● 5-10	● 5-10	● 5-10	● 5-10	○ 5-8	○ 5-8	○ 5-8	○ 5-8	○ 5-8	
	P.7	● 10-15	● 10-15	● 10-15	● 10-15	● 10-15	● 10-15	● 10-15	● 10-15	● 8-10	● 8-10	● 8-10	● 8-10	● 8-10	
M	M.1									● 8-10	● 8-10	● 8-10	● 8-10	● 8-10	
	M.2									● 5-7	● 5-7	● 5-7	● 5-7	● 5-7	
K	K.1														
	K.2	● 25-30	● 25-30	● 25-30	● 25-30	● 25-30	● 25-30	● 25-30	● 25-30	● 20-30	● 20-30	● 20-30	● 20-30	● 20-30	
	K.3														
N	N.1														
	N.2									○ 30-40	○ 30-40	○ 30-40	○ 30-40	○ 30-40	
	N.3	● 25-30	● 25-30	● 25-30	● 25-30	● 25-30	● 25-30	● 25-30	● 25-30	● 25-35	● 25-35	● 25-35	● 25-35	● 25-35	
	N.4														
	N.5														
	N.6	● 25-30	● 25-30	● 25-30	● 25-30	● 25-30	● 25-30	● 25-30	● 25-30	● 25-35	● 25-35	● 25-35	● 25-35	● 25-35	
	N.7	● 20-25	● 20-25	● 20-25	● 20-25	● 20-25	● 20-25	● 20-25	● 20-25						
	N.8														
	N.9														
	N.10														
S	S.1										● 10-15	● 10-15	● 10-15	● 10-15	
	S.2		● 2-3	● 2-3	● 2-3	● 2-3	● 2-3	● 2-3	● 2-3						
	S.3									● 10-15	● 10-15	● 10-15	● 10-15	● 10-15	
	S.4	● 2-3	● 2-3	● 2-3	● 2-3	● 2-3	● 2-3	● 2-3	● 2-3						
H	H.1														
	H.2														

TAP APPLICATION TABLE

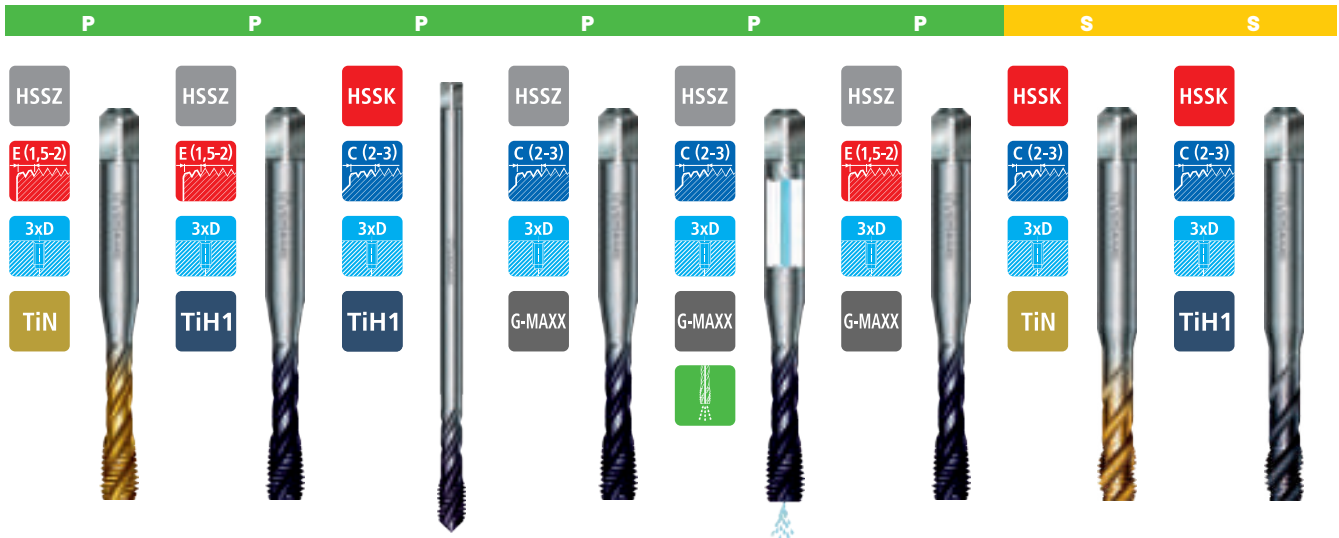

P70 E	146	P70 E	146	P76 L	147	P170	148	BP170	148	P170 E	148	S70	188	S70	188
		P70 E	146												
		P71 E	164			P171	165					S71	192		
		P71 E	164												

		P59 E	179												

○	25-35	○	25-35	○	25-35							●	45-55	●	45-55
●	20-30	●	20-30	●	20-30							●	45-55	●	45-55
●	15-25	●	15-25	●	15-25							●	40-50	●	40-50
●	5-15	●	5-15	●	5-15							●	35-45	●	35-45
○	5-8	○	5-8	○	5-8							●	15-20	●	15-20
●	8-10	●	8-10	●	8-10	●	10-15	●	10-15	●	10-15	●	15-20	●	15-20
●	8-10	●	8-10	●	8-10	●	10-15	●	10-15	●	10-15	●	15-20	●	15-20
●	5-7	●	5-7	●	5-7	●	6-8	●	6-8	●	6-8				
●	20-30	●	20-30	●	20-30							●	40-50	●	40-50
○	30-40	○	30-40	○	30-40							●	45-55	●	45-55
●	25-35	●	25-35	●	25-35							●	40-50	●	40-50
												●	35-45	●	35-45
●	25-35	●	25-35	●	25-35							●	30-40	●	30-40
		●	10-15	●	10-15									●	15-20
●	10-15	●	10-15	●	10-15							●	15-20	●	15-20
												○	5-15	○	5-15

TAP APPLICATION TABLE

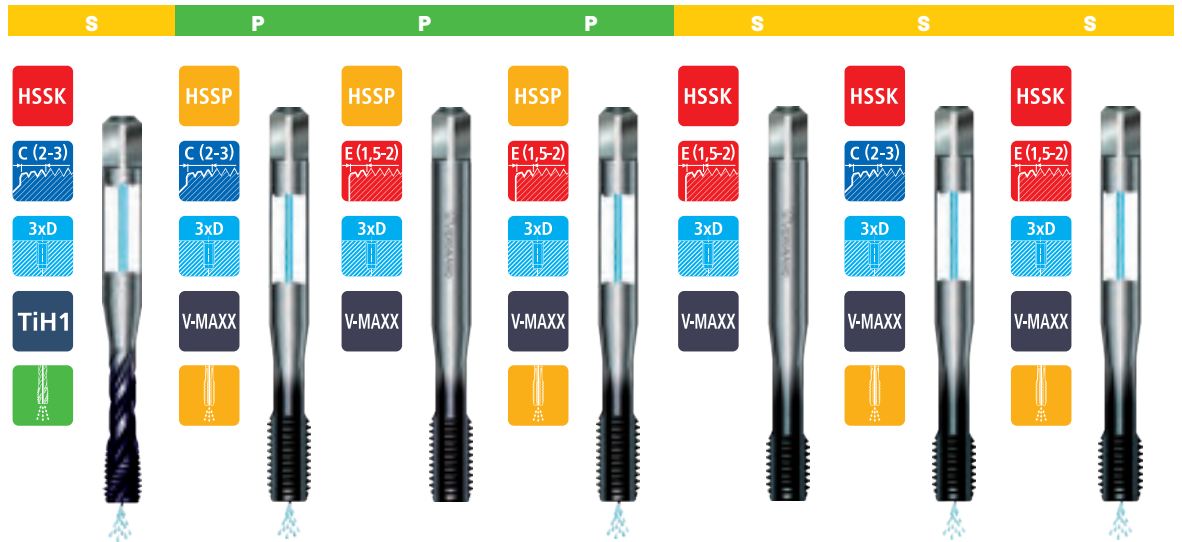

M	4H														
	6H/6HX	BS70	188	BP43	138	P43 E	138	BP43 E	138	S43 E	186	BS43	186	BS43 E	186
	6G/6GX														
	7G/7GX														
6H +0,1															
EG-M	6H MOD														
MF	6H/6HX			BP45	158	P45 E	152	BP45 E	158			BS45	190		
	6G/6GX														
UNC	2B/2BX														
	3B														
UNF	2B/2BX														
	3B														
8-UN	2B														
G	ISO 5969/X														
Rp(BSPP)	--														
Rc(BSPT)	--														
BSW	mc														
NPT	--														
NPTF	--														
ISO 513	Group														
P	P.1	●	45-55												
	P.2	●	45-55												
	P.3	●	40-50												
	P.4	●	35-45												
	P.5	●	15-20												
	P.6														
	P.7	●	15-20												
M	M.1	●	15-20												
	M.2														
K	K.1	●	40-50	●	40-50	●	40-50	●	55-65	●	55-65	●	55-65		
	K.2	●	40-50												
	K.3	○	10-20	○	10-20	○	10-20	○	20-30	○	20-30	○	20-30		
N	N.1	●	45-55												
	N.2	●	40-50												
	N.3	●	40-50												
	N.4			●	40-50	●	40-50	●	40-50	●	55-65	●	55-65	●	55-65
	N.5	●	35-45												
	N.6	●	30-40												
	N.7			●	40-50	●	40-50	●	40-50	●	55-65	●	55-65	●	55-65
	N.8														
	N.9			●	45-55	●	45-55	●	45-55	●	55-65	●	55-65	●	55-65
	N.10			●	45-55	●	45-55	●	45-55	●	55-65	●	55-65	●	55-65
S	S.1	●	15-20												
	S.2	○	5-15												
	S.3	●	15-20												
	S.4	○	5-15												
H	H.1														
	H.2														

TAP APPLICATION TABLE

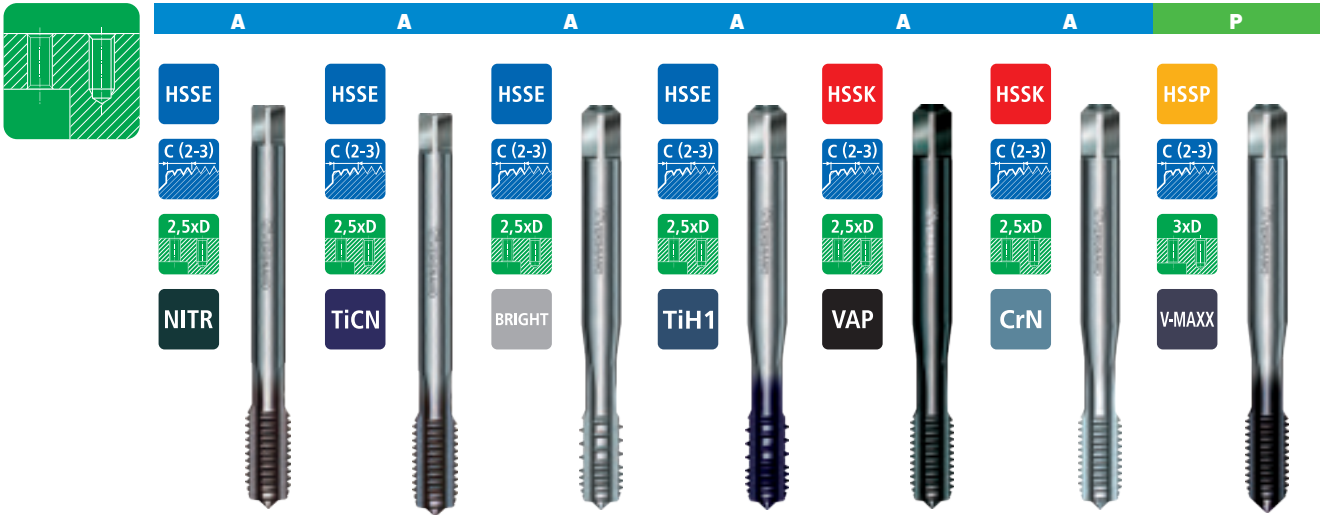

M	4H														
	6H/6HX	A44	42	A44	42	A67	43	A67	43	A110	44	A110	44	P43	138
	6G/6GX														
	7G/7GX														
	6H +0,1														
EG-M	6H MOD														
MF	6H/6HX													P45	158
	6G/6GX														
UNC	2B/2BX														
UNF	3B														
	2B/2BX														
8-UN	2B														
G	ISO 5969/X														
Rp(BSPP)	--														
Rc(BSPT)	--														
BSW	mc														
NPT	--														
NPTF	--														
ISO 513	Group														
P	P.1					●	12-15	●	20-25						
	P.2														
	P.3														
	P.4														
	P.5														
	P.6														
	P.7														
M	M.1														
	M.2														
K	K.1	●	15-20	●	40-45									●	40-50
	K.2														
	K.3													○	10-20
N	N.1					●	12-15	●	20-25						
	N.2					●	10-12	●	15-20						
	N.3														
	N.4	●	15-20	●	40-45									●	40-50
	N.5					●	10-12	●	15-20						
	N.6					●	8-10	●	12-15						
	N.7	●	15-20	●	40-45									●	40-50
	N.8														
	N.9	●	20-25	●	45-50									●	45-55
	N.10	●	20-25	●	45-50									●	45-55
S	S.1									●	6-8	●	10-12		
	S.2									●	3-5	●	6-8		
	S.3														
	S.4														
H	H.1														
	H.2														

TAP APPLICATION TABLE

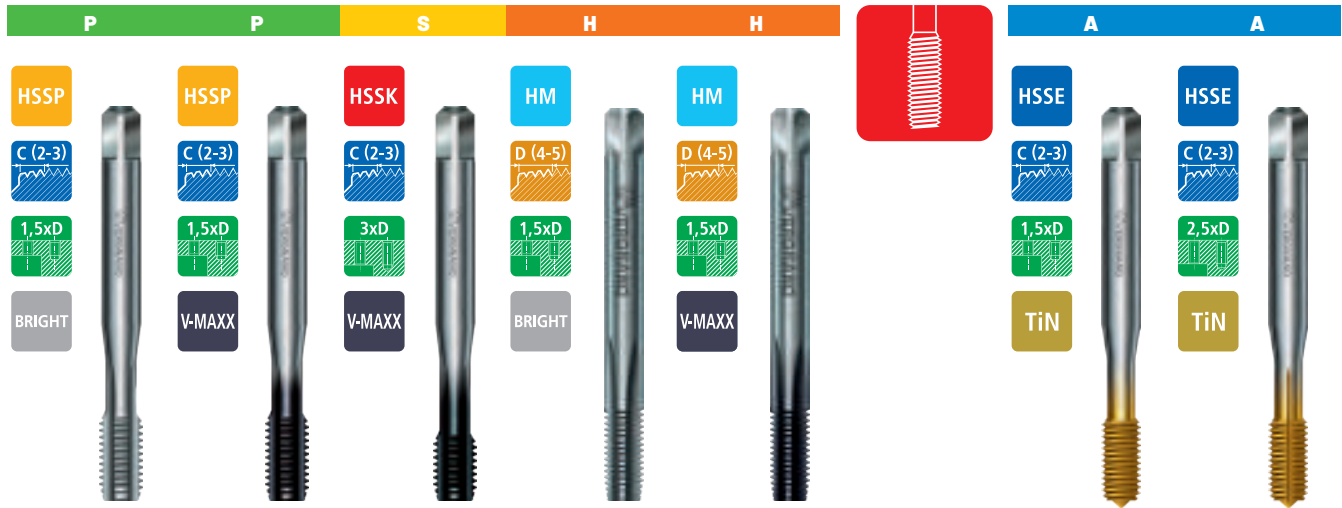

P130	139	P130	139	S43	186	H130	196	H130	196

				S45	190				

● 2-3		● 5-8				○ 2-5		○ 5-10	
				● 55-65					
				○ 20-30					
				● 55-65					
				● 55-65					
● 3-5		● 8-10							
				● 55-65					
				● 55-65					
						● 2-3		● 3-6	
						● 1-2		● 2-4	

A80	74	A80 N	75
A80	74	A80 N	75

A81	99	A81 N	100
A81	99	A81 N	100

		A82 N	126

● 20-25		● 20-25	
● 20-25		● 20-25	
● 15-20		● 15-20	
● 20-25		● 20-25	
● 20-25		● 20-25	
● 15-20		● 15-20	
● 20-25		● 20-25	
● 20-25		● 20-25	

TAP APPLICATION TABLE

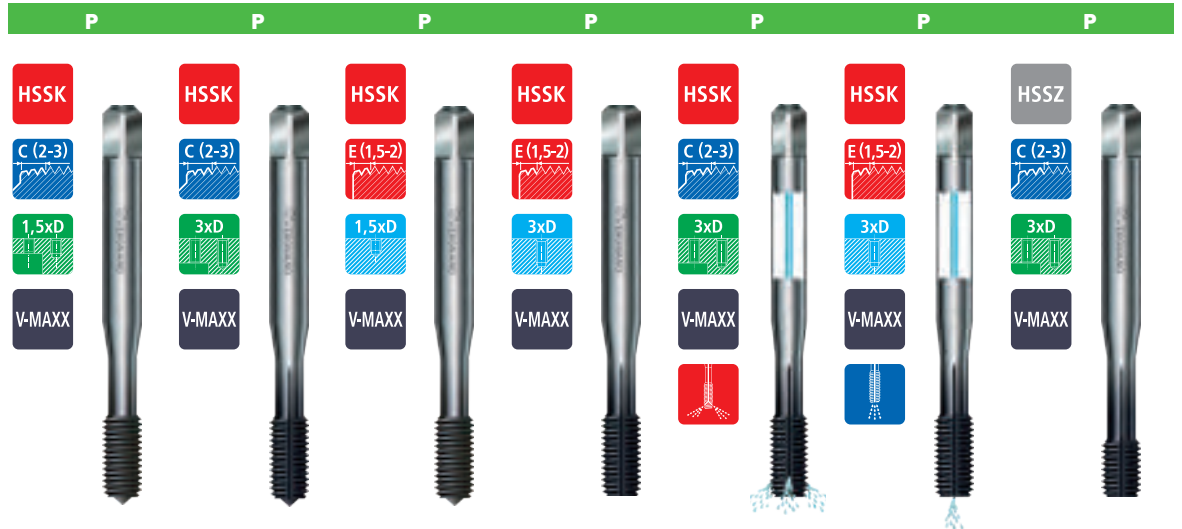

M	4H														
	6H/6HX	P80	149	P80 N	150	P80 E	151	P80 NE	151	BP80 N R	152	BP80 NE	152	P900 N	153
	6G/6GX	P80	149	P80 N	150			P80 NE	151						
	7G/7GX	P80	149	P80 N	150										
6H+0,1															
EG-M	6H MOD														
MF	6H/6HX	P81	166	P81 N	167									P901 N	168
	6G/6GX	P81	166	P81 N	167										
UNC	2B/2BX														
	3B														
UNF	2B/2BX														
	3B														
8-UN	2B														
G	ISO 5969/X			P82N	180								P902 N	181	
Rp(BSPP)	--														
Rc(BSPT)	--														
BSW	mc														
NPT	--														
NPTF	--														
ISO 513	Group														
P	P.1	●	20-25	●	20-25	●	20-25	●	20-25	●	20-25	●	20-25	●	40-45
	P.2	●	20-25	●	20-25	●	20-25	●	20-25	●	20-25	●	20-25	●	40-45
	P.3	●	15-20	●	15-20	●	15-20	●	15-20	●	15-20	●	15-20	●	35-40
	P.4														●
	P.5														●
	P.6														
	P.7														●
M	M.1														●
	M.2														●
K	K.1														
	K.2														
	K.3														
N	N.1	●	20-25	●	20-25	●	20-25	●	20-25	●	20-25	●	20-25	●	40-45
	N.2	●	20-25	●	20-25	●	20-25	●	20-25	●	20-25	●	20-25	●	40-45
	N.3	●	15-20	●	15-20	●	15-20	●	15-20	●	15-20	●	15-20	●	35-40
	N.4														
	N.5	●	20-25	●	20-25	●	20-25	●	20-25	●	20-25	●	20-25	●	40-45
	N.6	●	20-25	●	20-25	●	20-25	●	20-25	●	20-25	●	20-25	●	40-45
	N.7														
	N.8														
	N.9														
	N.10														
S	S.1														
	S.2														
	S.3														
	S.4														●
H	H.1														
	H.2														

TAP APPLICATION TABLE

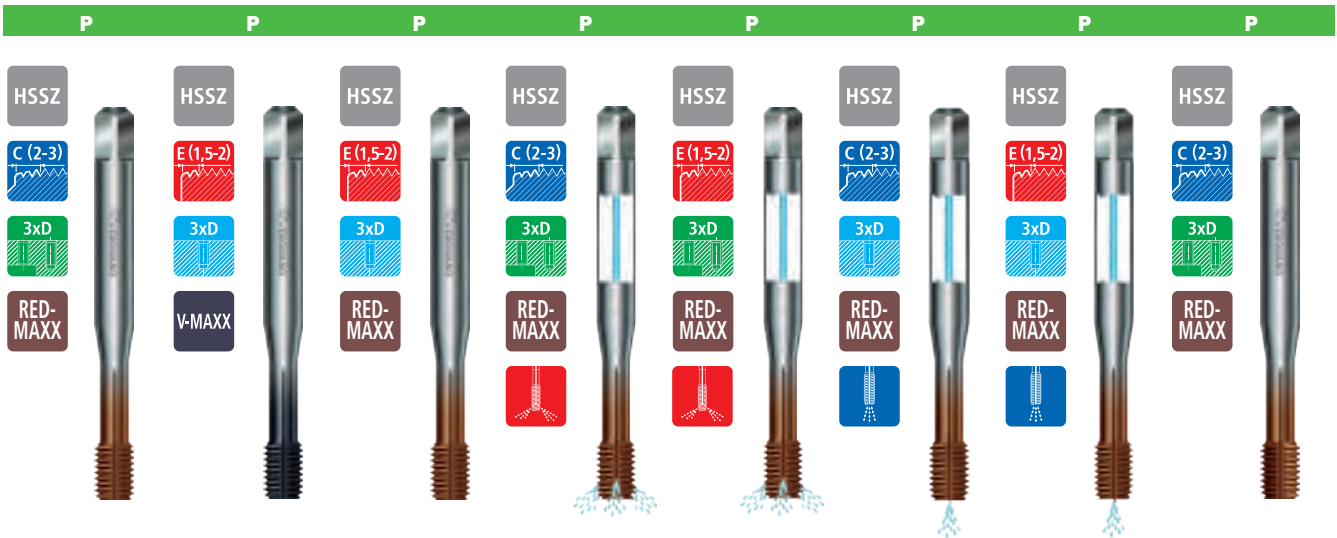

P900 N	153	P900 NE	154	P900 NE	154	BP900 N R	155	BP900 N RE	155	BP900 N	155	BP900 NE	155	P900 N LH	156
P900 N	153			P900 NE	154										
P900 N	153														

P901 N	168	P901 NE	169	P901 NE	169	BP901 N R	170								
P901 N	168			P901 NE	169										
		P903 NE	173	P903 NE	176										

		P904 NE	176	P904 NE	162										
--	--	---------	-----	---------	-----	--	--	--	--	--	--	--	--	--	--

P902 N	181	P902 NE	182	P902 NE	182	BP902 N R	183								
--------	-----	---------	-----	---------	-----	-----------	-----	--	--	--	--	--	--	--	--

●	40-45	●	40-45	●	40-45	●	40-45	●	40-45	●	40-45	●	40-45	●	40-45
●	40-45	●	40-45	●	40-45	●	40-45	●	40-45	●	40-45	●	40-45	●	40-45
●	35-40	●	35-40	●	35-40	●	35-40	●	35-40	●	35-40	●	35-40	●	35-40
●	30-35	●	30-35	●	30-35	●	30-35	●	30-35	●	30-35	●	30-35	●	30-35
●	15-20	●	15-20	●	15-20	●	15-20	●	15-20	●	15-20	●	15-20	●	15-20

○	10-15	●	10-15	○	10-15	○	10-15	○	10-15	○	10-15	○	10-15	○	10-15
○	10-15	●	10-15	○	10-15	○	10-15	○	10-15	○	10-15	○	10-15	○	10-15

●	40-45	●	40-45	●	40-45	●	40-45	●	40-45	●	40-45	●	40-45	●	40-45
●	40-45	●	40-45	●	40-45	●	40-45	●	40-45	●	40-45	●	40-45	●	40-45
●	35-40	●	35-40	●	35-40	●	35-40	●	35-40	●	35-40	●	35-40	●	35-40

●	40-45	●	40-45	●	40-45	●	40-45	●	40-45	●	40-45	●	40-45	●	40-45
●	40-45	●	40-45	●	40-45	●	40-45	●	40-45	●	40-45	●	40-45	●	40-45

●	10-15	●	10-15	●	10-15	●	10-15	●	10-15	●	10-15	●	10-15	●	10-15
---	-------	---	-------	---	-------	---	-------	---	-------	---	-------	---	-------	---	-------

TAP APPLICATION TABLE



		P		S		S		S		H		H		OLIO DA TAGLIO
M	4H													VTO-100 Suitable for tapping with cutting or forming taps on all materials. Available only in EU countries.
	6H/6HX	P900 NL	157	S80 N	189	S80 N	189	BS80 NR	189	HB80 NR	197	HB80 NRE	197	
	6G/6GX			S80 N	189									
	7G/7GX													
	6H +0,1													
EG-M	6H MOD													
MF	6H/6HX											HB81 NRE	199	€ P.74
	6G/6GX													
UNC	2B/2BX													
	3B													
UNF	2B/2BX													
	3B													
8-UN	2B													
G	ISO 5969/X													
Rp(BSPP)	--													
Rc(BSPT)	--													
BSW	mc													
NPT	--													
NPTF	--													
ISO 513	Group													
P	P.1	●	40-45	●	50-60	●	50-60	●	50-60	●	40-50	●	40-50	
	P.2	●	40-45	●	50-60	●	50-60	●	50-60	●	40-50	●	40-50	
	P.3	●	35-40	●	45-55	●	45-55	●	45-55	●	35-45	●	35-45	
	P.4	●	30-35	●	40-50	●	40-50	●	40-50	●	30-40	●	30-40	
	P.5	●	15-20	●	20-30	●	20-30	●	20-30	●	15-25	●	15-25	
	P.6													
M	P.7	○	10-15	●	10-20	●	10-20	●	10-20	●	10-20	●	10-20	
	M.1	○	10-15	●	10-20	●	10-20	●	10-20	●	10-20	●	10-20	
K	M.2													
	K.1													
	K.2													
N	K.3													
	N.1	●	40-45	●	50-60	●	50-60	●	50-60	●	40-50	●	40-50	
	N.2	●	40-45	●	50-60	●	50-60	●	50-60	●	40-50	●	40-50	
	N.3	●	35-40	●	45-55	●	45-55	●	45-55	●	35-45	●	35-45	
	N.4													
	N.5	●	40-45	●	50-60	●	50-60	●	50-60	●	40-50	●	40-50	
	N.6	●	40-45	●	50-60	●	50-60	●	50-60	●	40-50	●	40-50	
	N.7													
	N.8													
	N.9													
S	N.10													
	S.1													
	S.2													
	S.3	●	10-15	●	10-20	●	10-20	●	10-20	●	10-20	●	10-20	
H	S.4													
	H.1													
	H.2													



A SERIES

TAPS FOR GENERIC APPLICATIONS





A1
ROUGHING

A1
SECOND

A1
FINISHING

A1
SET

A SERIES

DIN 352
≤ M6

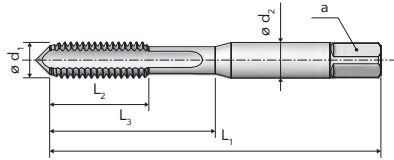

DIN 352
≥ M7

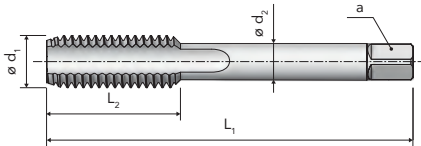

APPLICATION RANGE - CUTTING SPEED m/min

ISO	MG	A1 ROUGHING	A1 SECOND	A1 FINISHING	A1 SET
P	P.1-4	•	•	•	•
	P.7	•	•	•	•
K	K.2	•	•	•	•
N	N.1-3	•	•	•	•
	N.5-7	•	•	•	•

—	—	ISO2 6H	ISO2 6H
A (5-6)	D (4-5)	C (2-3)	C (2-3)
2,5xD	2,5xD	2,5xD	2,5xD
RH	RH	RH	RH

Ød ₁	P	L ₁ js 16	L ₂	L ₃	Ød ₂ h9	a h12	Z	z	Ø	A1 ROUGHING ...0011A1AA0	A1 SECOND ...0011A2AA0	A1 FINISHING ...0011A3AA0	A1 SET ...0011ASAA0
[mm]	[mm]	[mm]	[mm]	[mm]	[mm]	[mm]	[-]	[mm]	[mm]				
M 2	0,4	36	7,5	12	2,8	2,1	3	1,6		A00020...	A00020...	A00020...	A00020...
2,2	0,45	36	8,5	13,5	2,8	2,1	3	1,75		A00022...	A00022...	A00022...	A00022...
2,3	0,4	36	8,5	13,5	2,8	2,1	3	1,9		A00023...	A00023...	A00023...	A00023...
2,5	0,45	40	8,5	14,5	2,8	2,1	3	2,05		A00025...	A00025...	A00025...	A00025...
2,6	0,45	40	8,5	14,5	2,8	2,1	3	2,1		A00026...	A00026...	A00026...	A00026...
3	0,5	40	10	18	3,5	2,7	3	2,5		A00030...	A00030...	A00030...	A00030...
3,5	0,6	45	11	20	4	3	3	2,9		A00035...	A00035...	A00035...	A00035...
4	0,7	45	12	21	4,5	3,4	3	3,3		A00040...	A00040...	A00040...	A00040...
4,5	0,75	50	13	23	6	4,9	3	3,7		A00045...	A00045...	A00045...	A00045...
5	0,8	50	14	24	6	4,9	3	4,2		A00050...	A00050...	A00050...	A00050...
6	1	56	16	28	6	4,9	3	5		A00060...	A00060...	A00060...	A00060...
7	1	56	19	-	6	4,9	3	6		A00070...	A00070...	A00070...	A00070...
8	1,25	63	22	-	6	4,9	3	6,8		A00080...	A00080...	A00080...	A00080...
9	1,25	63	22	-	7	5,5	3	7,8		A00090...	A00090...	A00090...	A00090...
10	1,5	70	24	-	7	5,5	3	8,5		A00100...	A00100...	A00100...	A00100...
11	1,5	70	24	-	8	6,2	3	9,5		A00110...	A00110...	A00110...	A00110...
12	1,75	75	28	-	9	7	4	10,2		A00120...	A00120...	A00120...	A00120...
14	2	80	30	-	11	9	4	12		A00140...	A00140...	A00140...	A00140...
16	2	80	32	-	12	9	4	14		A00160...	A00160...	A00160...	A00160...
18	2,5	95	34	-	14	11	4	15,5		A00180...	A00180...	A00180...	A00180...
20	2,5	95	34	-	16	12	4	17,5		A00200...	A00200...	A00200...	A00200...
22	2,5	100	34	-	18	14,5	4	19,5		A00220...	A00220...	A00220...	A00220...
24	3	110	38	-	18	14,5	4	21		A00240...	A00240...	A00240...	A00240...
27	3	110	38	-	20	16	4	24		A00270...	A00270...	A00270...	A00270...
30	3,5	125	45	-	22	18	4	26,5		A00300...	A00300...	A00300...	A00300...
33	3,5	125	50	-	25	20	4	29,5		A00330...	A00330...	A00330...	A00330...





A1
ROUGHING

A1
SECOND

A1
FINISHING

A1
SET

DIN 352

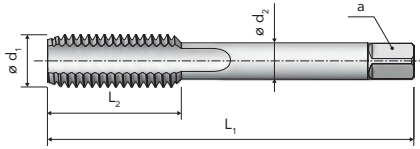

APPLICATION RANGE - CUTTING SPEED m/min

ISO	MG	A1 ROUGHING	A1 SECOND	A1 FINISHING	A1 SET
P	P.1-4	•	•	•	•
	P.7	•	•	•	•
K	K.2	•	•	•	•
N	N.1-3	•	•	•	•
	N.5-7	•	•	•	•

—	—	ISO2 6H	ISO2 6H

A SERIES

Ød ₁	P	L ₁ js16	L ₂	L ₃	Ød ₂ h9	a h12	z		A1 ROUGHING ...0011A1AA0	A1 SECOND ...0011A2AA0	A1 FINISHING ...0011A3AA0	A1 SET ...0011ASAA0
[mm]	[mm]	[mm]	[mm]	[mm]	[mm]	[mm]	[-]	[mm]				
M 36	4	150	56	-	28	22	4	32	A00360...	A00360...	A00360...	A00360...
39	4	150	60	-	32	24	4	35	A00390...	A00390...	A00390...	A00390...
42	4,5	150	60	-	32	24	4	37,5	A00420...	A00420...	A00420...	A00420...
45	4,5	160	65	-	36	29	4	40,5	A00450...	A00450...	A00450...	A00450...
48	5	180	70	-	36	29	4	43	A00480...	A00480...	A00480...	A00480...
52	5	180	70	-	40	32	5	47	A00520...	A00520...	A00520...	A00520...
56	5,5	180	70	-	40	32	5	50,5	A00560...	A00560...	A00560...	A00560...



A1LH
ROUGHING

A1LH
SECOND

A1LH
FINISHING

A1LH
SET

A SERIES

DIN 352
≤ M6

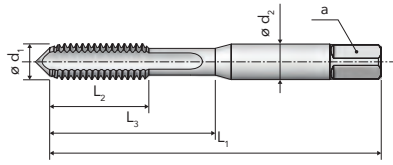

DIN 352
≥ M8

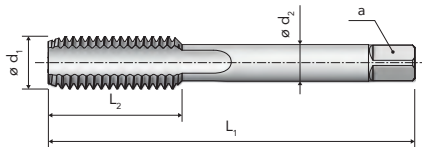

APPLICATION RANGE - CUTTING SPEED m/min

ISO	MG	A1LH ROUGHING	A1LH SECOND	A1LH FINISHING	A1LH SET
P	P.1-4	•	•	•	•
	P.7	•	•	•	•
K	K.2	•	•	•	•
N	N.1-3	•	•	•	•
	N.5-7	•	•	•	•

—	—	ISO2 6H	ISO2 6H
A (5-6)	D (4-5)	C (2-3)	C (2-3)
2,5xD	2,5xD	2,5xD	2,5xD
LH	LH	LH	LH

Ød ₁	P	L ₁ js 16	L ₂	L ₃	Ød ₂ h9	a h12	Z		A1LH ROUGHING ...0011C1AA0	A1LH SECOND ...0011C2AA0	A1LH FINISHING ...0011C3AA0	A1LH SET ...0011CSAA0
[mm]	[mm]	[mm]	[mm]	[mm]	[mm]	[mm]	[-]	[mm]				
M 2,6	0,45	40	8,5	14,5	2,8	2,1	3	2,1	A00026...	A00026...	A00026...	A00026...
3	0,5	40	10	18	3,5	2,7	3	2,5	A00030...	A00030...	A00030...	A00030...
3,5	0,6	45	11	20	4	3	3	2,9	A00035...	A00035...	A00035...	A00035...
4	0,7	45	12	21	4,5	3,4	3	3,3	A00040...	A00040...	A00040...	A00040...
5	0,8	50	14	24	6	4,9	3	4,2	A00050...	A00050...	A00050...	A00050...
6	1	56	16	28	6	4,9	3	5	A00060...	A00060...	A00060...	A00060...
8	1,25	63	22	-	6	4,9	3	6,8	A00080...	A00080...	A00080...	A00080...
10	1,5	70	24	-	7	5,5	3	8,5	A00100...	A00100...	A00100...	A00100...
12	1,75	75	28	-	9	7	4	10,2	A00120...	A00120...	A00120...	A00120...
14	2	80	30	-	11	9	4	12	A00140...	A00140...	A00140...	A00140...
16	2	80	32	-	12	9	4	14	A00160...	A00160...	A00160...	A00160...
18	2,5	95	34	-	14	11	4	15,5	A00180...	A00180...	A00180...	A00180...
20	2,5	95	34	-	16	12	4	17,5	A00200...	A00200...	A00200...	A00200...
22	2,5	100	34	-	18	14,5	4	19,5	A00220...	A00220...	A00220...	A00220...
24	3	110	38	-	18	14,5	4	21	A00240...	A00240...	A00240...	A00240...
27	3	110	38	-	20	16	4	24	A00270...	A00270...	A00270...	A00270...
30	3,5	125	45	-	22	18	4	26,5	A00300...	A00300...	A00300...	A00300...



A100
ROUGHING

A100
SECOND

A100
FINISHING

A100
SET

DIN 352
≤ M6

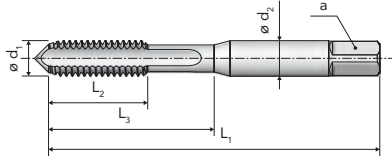

DIN 352
≥ M8

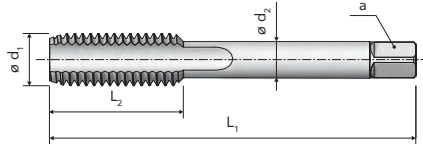

A SERIES

APPLICATION RANGE - CUTTING SPEED m/min

ISO	MG	A100 ROUGHING	A100 SECOND	A100 FINISHING	A100 SET
P	P.1-5	•	•	•	•
	P.7	•	•	•	•
M	M.1-2	•	•	•	•
K	K.1-3	•	•	•	•
N	N.1-10	•	•	•	•
S	S.1	•	•	•	•
	S.3	•	•	•	•

—	—	ISO2 6H	ISO2 6H
C (2-3)	C (2-3)	C (2-3)	C (2-3)
2,5xD	2,5xD	2,5xD	2,5xD
RH	RH	RH	RH

$\varnothing d_1$	P	L_1 js16	L_2	L_3	$\varnothing d_2$ h9	a h12	z		A100 ROUGHING ...1002A1AA0	A100 SECOND ...1002A2AA0	A100 FINISHING ...1002A3AA0	A100 SET ...1002ASAA0
[mm]	[mm]	[mm]	[mm]	[mm]	[mm]	[mm]	[-]	[mm]				
M2	0,4	36	7,5	13	2,8	2,1	3	1,6	A00020...	A00020...	A00020...	A00020...
2,5	0,45	40	9	15	2,8	2,1	3	2,05	A00025...	A00025...	A00025...	A00025...
3	0,5	40	10	18	3,5	2,7	3	2,5	A00030...	A00030...	A00030...	A00030...
3,5	0,6	45	11	18	4	3	3	2,9	A00035...	A00035...	A00035...	A00035...
4	0,7	45	12	21	4,5	3,4	3	3,3	A00040...	A00040...	A00040...	A00040...
5	0,8	50	14	24	6	4,9	3	4,2	A00050...	A00050...	A00050...	A00050...
6	1	56	16	28	6	4,9	3	5	A00060...	A00060...	A00060...	A00060...
8	1,25	63	22	-	6	4,9	4	6,8	A00080...	A00080...	A00080...	A00080...
10	1,5	70	24	-	7	5,5	4	8,5	A00100...	A00100...	A00100...	A00100...
12	1,75	75	28	-	9	7	4	10,2	A00120...	A00120...	A00120...	A00120...
14	2	80	30	-	11	9	4	12	A00140...	A00140...	A00140...	A00140...
16	2	80	32	-	12	9	4	14	A00160...	A00160...	A00160...	A00160...
18	2,5	95	34	-	14	11	4	15,5	A00180...	A00180...	A00180...	A00180...
20	2,5	95	34	-	16	12	4	17,5	A00200...	A00200...	A00200...	A00200...



A21 FC
BRIGHT

A21 FC
TiN

A SERIES

DIN 371
≤ M10

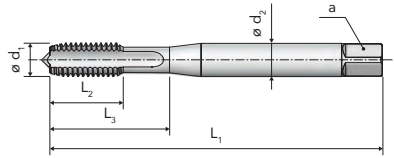

DIN 376
≥ M11

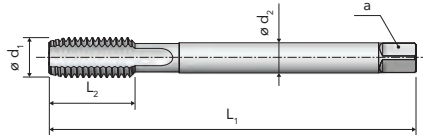

APPLICATION RANGE - CUTTING SPEED m/min

ISO	MG	A21 FC BRIGHT	A21 FC TiN
P	P.1		• 20-25
	P.2	• 10-12	• 15-20
	P.3	• 8-10	• 12-15
K	K.2	• 8-10	• 12-15
N	N.1		• 20-25
	N.5		• 15-20



Ød ₁	P	L ₁ js 16	L ₂	L ₃	Ød ₂ h9	a h12	Z		A21 FC BRIGHT ...0212A1AA0	A21 FC TiN ...0212A1ADO
[mm]	[mm]	[mm]	[mm]	[mm]	[mm]	[mm]	[-]	[mm]		
M 2	0,4	45	7	11	2,8	2,1	3	1,6	A00020...	A00020...
2,5	0,45	50	9	15	2,8	2,1	3	2,05	A00025...	A00025...
3	0,5	56	10	18	3,5	2,7	3	2,5	A00030...	A00030...
3,5	0,6	56	11	20	4	3	3	2,9	A00035...	A00035...
4	0,7	63	12	21	4,5	3,4	3	3,3	A00040...	A00040...
5	0,8	70	14	24,5	6	4,9	3	4,2	A00050...	A00050...
6	1	80	16	29	6	4,9	3	5	A00060...	A00060...
7	1	80	16	29	7	5,5	3	6	A00070...	A00070...
8	1,25	90	18	33	8	6,2	3	6,8	A00080...	A00080...
9	1,25	90	18	33	9	7	3	7,8	A00090...	A00090...
10	1,5	100	20	36	10	8	3	8,5	A00100...	A00100...
11	1,5	100	22	-	8	6,2	3	9,5	A00110...	A00110...
12	1,75	110	24	-	9	7	3	10,2	A00120...	A00120...
14	2	110	25	-	11	9	3	12	A00140...	A00140...
16	2	110	28	-	12	9	3	14	A00160...	A00160...
18	2,5	125	32	-	14	11	3	15,5	A00180...	A00180...
20	2,5	140	32	-	16	12	4	17,5	A00200...	A00200...
22	2,5	140	32	-	18	14,5	4	19,5	A00220...	A00220...
24	3	160	36	-	18	14,5	4	21	A00240...	A00240...
27	3	160	36	-	20	16	4	24	A00270...	A00270...
30	3,5	180	40	-	22	18	4	26,5	A00300...	A00300...
33	3,5	180	40	-	25	20	4	29,5	A00330...	A00330...
36	4	200	55	-	28	22	4	32	A00360...	A00360...
39	4	200	60	-	32	24	4	35	A00390...	
42	4,5	200	60	-	32	24	4	37,5	A00420...	
45	4,5	220	65	-	36	29	4	40,5	A00450...	





A21FC
BRIGHT

DIN 376

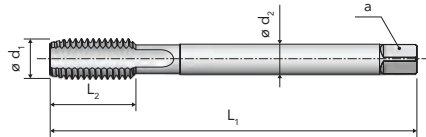

A SERIES

APPLICATION RANGE - CUTTING SPEED m/min

ISO	MG	A21FC BRIGHT			
P	P.2	• 10-12			
	P.3	• 8-10			
K	K.2	• 8-10			



$\varnothing d_1$	P	L_1 js 16	L_2	L_3	$\varnothing d_2$ h9	a h12	z		A21FC BRIGHT ...0212A1AA0			
[mm]	[mm]	[mm]	[mm]	[mm]	[mm]	[mm]	[-]	[mm]				
M 48	5	250	70	-	36	29	4	43	A00480...			
52	5	250	70	-	40	32	4	47	A00520...			



A22 FC
BRIGHT

A22 FC
TiN

A SERIES

DIN 376

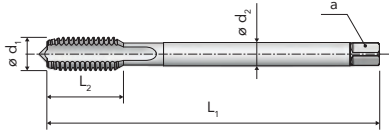

APPLICATION RANGE - CUTTING SPEED m/min

ISO	MG	A22 FC BRIGHT	A22 FC TiN
P	P.1		• 20-25
	P.2	• 10-12	• 15-20
	P.3	• 8-10	• 12-15
K	K.2	• 8-10	• 12-15
N	N.1		• 20-25
	N.5		• 15-20

ISO2
6H

ISO2
6H



Ød ₁	P	L ₁ js 16	L ₂	L ₃	Ød ₂ h9	a h12	z		A22 FC BRIGHT ...0222A1AA0	A22 FC TiN ...0222A1AD0
[mm]	[mm]	[mm]	[mm]	[mm]	[mm]	[mm]	[-]	[mm]		
M 4	0,7	63	12	-	2,8	2,1	3	3,3	A00040...	A00040...
5	0,8	70	14	-	3,5	2,7	3	4,2	A00050...	A00050...
6	1	80	16	-	4,5	3,4	3	5	A00060...	A00060...
7	1	80	16	-	5,5	4,3	3	6	A00070...	A00070...
8	1,25	90	18	-	6	4,9	3	6,8	A00080...	A00080...
9	1,25	90	18	-	7	5,5	3	7,8	A00090...	A00090...
10	1,5	100	20	-	7	5,5	3	8,5	A00100...	A00100...



A43
NITRIDED

A43
TiCN

DIN 371
≤ M10

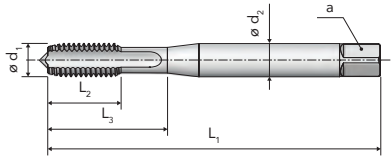

DIN 376
≥ M11

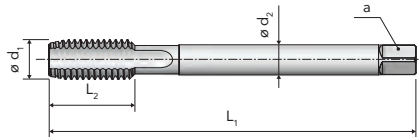

A
SERIES

APPLICATION RANGE - CUTTING SPEED m/min

ISO	MG	A43 NITRIDED	A43 TiCN
K	K.1	• 15-20	• 40-45
N	N.4	• 15-20	• 40-45
	N.7	• 15-20	• 40-45
	N.9-10	• 20-25	• 45-50



Ød ₁	P	L ₁ js16	L ₂	L ₃	Ød ₂ h9	a h12	Z		A43 NITRIDED ...0432A1ACO	A43 TiCN ...0432A1AEO
[mm]	[mm]	[mm]	[mm]	[mm]	[mm]	[mm]	[-]	[mm]		
M 3	0,5	56	10	18	3,5	2,7	3	2,5	A00030...	A00030...
3,5	0,6	56	11	20	4	3	3	2,9	A00035...	A00035...
4	0,7	63	12	21	4,5	3,4	3	3,3	A00040...	A00040...
5	0,8	70	14	24,5	6	4,9	3	4,2	A00050...	A00050...
6	1	80	16	29	6	4,9	4	5	A00060...	A00060...
7	1	80	16	29	7	5,5	4	6	A00070...	A00070...
8	1,25	90	18	33	8	6,2	4	6,8	A00080...	A00080...
9	1,25	90	18	33	9	7	4	7,8	A00090...	A00090...
10	1,5	100	20	36	10	8	4	8,5	A00100...	A00100...
11	1,5	100	22	-	8	6,2	4	9,5	A00110...	A00110...
12	1,75	110	24	-	9	7	4	10,2	A00120...	A00120...
14	2	110	25	-	11	9	4	12	A00140...	A00140...
16	2	110	28	-	12	9	4	14	A00160...	A00160...
18	2,5	125	32	-	14	11	4	15,5	A00180...	A00180...
20	2,5	140	32	-	16	12	4	17,5	A00200...	A00200...
22	2,5	140	32	-	18	14,5	4	19,5	A00220...	A00220...
24	3	160	36	-	18	14,5	5	21	A00240...	A00240...
27	3	160	36	-	20	16	5	24	A00270...	A00270...
30	3,5	180	40	-	22	18	5	26,5	A00300...	A00300...
33	3,5	180	40	-	25	20	5	29,5	A00330...	A00330...
36	4	200	55	-	28	22	5	32	A00360...	A00360...



A44
NITRIDED

A44
TiCN

A SERIES

DIN 376

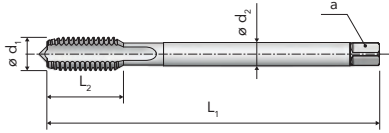

APPLICATION RANGE - CUTTING SPEED m/min

ISO	MG	A44 NITRIDED	A44 TiCN
K	K.1	• 15-20	• 40-45
	N.4	• 15-20	• 40-45
N	N.7	• 15-20	• 40-45
	N.9-10	• 20-25	• 45-50



Ød ₁	P	L ₁ js 16	L ₂	L ₃	Ød ₂ h9	a h12	z		A44 NITRIDED ...0442A1ACO	A44 TiCN ...0442A1AEO
[mm]	[mm]	[mm]	[mm]	[mm]	[mm]	[mm]	[-]	[mm]		
M 4	0,7	63	12	-	2,8	2,1	3	3,3	A00040...	A00040...
5	0,8	70	14	-	3,5	2,7	3	4,2	A00050...	A00050...
6	1	80	16	-	4,5	3,4	4	5	A00060...	A00060...
8	1,25	90	18	-	6	4,9	4	6,8	A00080...	A00080...
10	1,5	100	20	-	7	5,5	4	8,5	A00100...	A00100...



A67
BRIGHT

A67
TiH1

DIN 371
≤ M10

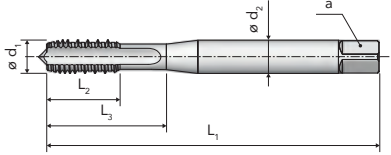

DIN 376
≥ M12

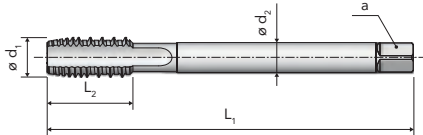

A SERIES

APPLICATION RANGE - CUTTING SPEED m/min

ISO	MG	A67 BRIGHT	A67 TiH1
P	P.1	• 12-15	• 20-25
	N.1	• 12-15	• 20-25
N	N.2	• 10-12	• 15-20
	N.5	• 10-12	• 15-20
	N.6	• 8-10	• 12-15



Ød ₁	P	L ₁ js 16	L ₂	L ₃	Ød ₂ h9	a h12	Z		A67 BRIGHT ...0672A1AA0	A67 TiH1 ...0672A1AH0
[mm]	[mm]	[mm]	[mm]	[mm]	[mm]	[mm]	[-]	[mm]		
M 3	0,5	56	10	18	3,5	2,7	3	2,5	A00030...	A00030...
4	0,7	63	12	21	4,5	3,4	3	3,3	A00040...	A00040...
5	0,8	70	14	24,5	6	4,9	3	4,2	A00050...	A00050...
6	1	80	16	29	6	4,9	3	5	A00060...	A00060...
8	1,25	90	18	33	8	6,2	3	6,8	A00080...	A00080...
10	1,5	100	20	36	10	8	3	8,5	A00100...	A00100...
12	1,75	110	24	-	9	7	3	10,2	A00120...	A00120...
14	2	110	25	-	11	9	3	12	A00140...	A00140...
16	2	110	28	-	12	9	3	14	A00160...	A00160...
18	2,5	125	32	-	14	11	3	15,5	A00180...	A00180...
20	2,5	140	32	-	16	12	3	17,5	A00200...	A00200...



A110
VAP

A110
CrN

A SERIES

DIN 371
≤ M10

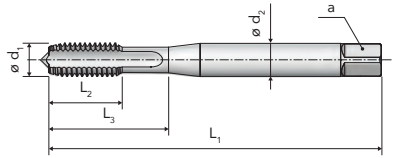

DIN 376
≥ M12

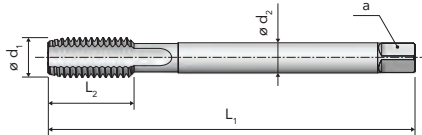

APPLICATION RANGE - CUTTING SPEED m/min

ISO	MG	A110 VAP	A110 CrN
S	S.1	• 6-8	• 10-12
	S.2	• 3-5	• 6-8



Ød ₁	P	L ₁ js 16	L ₂	L ₃	Ød ₂ h9	a h12	Z		A110 VAP ...1103A1ACO	A110 CrN ...1103A1ANO
[mm]	[mm]	[mm]	[mm]	[mm]	[mm]	[mm]	[-]	[mm]		
M 2	0,4	45	7	11	2,8	2,1	3	1,6	A00020...	A00020...
2,5	0,45	50	9	15	2,8	2,1	3	2,05	A00025...	A00025...
3	0,5	56	10	18	3,5	2,7	3	2,5	A00030...	A00030...
4	0,7	63	12	21	4,5	3,4	3	3,3	A00040...	A00040...
5	0,8	70	14	24,5	6	4,9	3	4,2	A00050...	A00050...
6	1	80	16	29	6	4,9	4	5	A00060...	A00060...
8	1,25	90	18	33	8	6,2	4	6,8	A00080...	A00080...
10	1,5	100	20	36	10	8	4	8,5	A00100...	A00100...
12	1,75	110	24	-	9	7	4	10,2	A00120...	A00120...
14	2	110	25	-	11	9	4	12	A00140...	A00140...
16	2	110	28	-	12	9	4	14	A00160...	A00160...
18	2,5	125	32	-	14	11	4	15,5	A00180...	A00180...
20	2,5	140	32	-	16	12	4	17,5	A00200...	A00200...



A15 S
BRIGHT

A15 S
VAP

A15 S
TiN

A15 S
TiCN

DIN 371
≤ M10

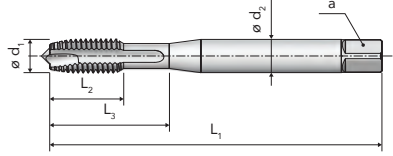

DIN 376
≥ M11

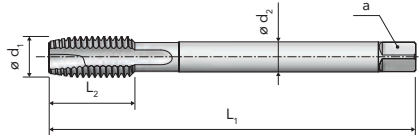

A SERIES

APPLICATION RANGE - CUTTING SPEED m/min

ISO	MG	A15 S BRIGHT	A15 S VAP	A15 S TiN	A15 S TiCN
P	P.2	● 20-25	● 20-25	● 30-35	● 30-35
	P.3	● 15-20	● 15-20	● 25-30	● 25-30
	P.4	● 12-15	● 12-15	● 20-25	● 20-25
	P.5			● 10-15	● 10-15
	P.7			● 8-10	● 8-10
M	M.1			● 8-10	● 8-10
K	K.2	● 15-20	● 15-20	● 25-30	● 25-30
N	N.2-3	● 20-25	● 20-25	● 30-35	● 30-35
	N.6	● 15-18	● 15-18	● 25-30	● 25-30



Ød ₁	P	L ₁ js16	L ₂	L ₃	Ød ₂ h9	a h12	Z		A15 S BRIGHT ...0152B2AA0	A15 S VAP ...0152B2AB0	A15 S TiN ...0152B2AD0	A15 S TiCN ...0152B2AE0
[mm]	[mm]	[mm]	[mm]	[mm]	[mm]	[mm]	[-]	[mm]				
M2	0,4	45	7	11	2,8	2,1	2	1,6	A00020...	A00020...	A00020...	A00020...
2,2	0,45	45	8	13	2,8	2,1	2	1,75	A00022...	A00022...	A00022...	
2,3	0,4	45	8	13	2,8	2,1	2	1,9	A00023...	A00023...	A00023...	
2,5	0,45	50	9	15	2,8	2,1	3	2,05	A00025...	A00025...	A00025...	A00025...
2,6	0,45	50	9	15	2,8	2,1	3	2,1	A00026...	A00026...	A00026...	
3	0,5	56	10	18	3,5	2,7	3	2,5	A00030...	A00030...	A00030...	A00030...
3,5	0,6	56	11	20	4	3	3	2,9	A00035...	A00035...	A00035...	A00035...
4	0,7	63	12	21	4,5	3,4	3	3,3	A00040...	A00040...	A00040...	A00040...
5	0,8	70	14	24,5	6	4,9	3	4,2	A00050...	A00050...	A00050...	A00050...
6	1	80	16	29	6	4,9	3	5	A00060...	A00060...	A00060...	A00060...
7	1	80	16	29	7	5,5	3	6	A00070...	A00070...	A00070...	A00070...
8	1,25	90	18	33	8	6,2	3	6,8	A00080...	A00080...	A00080...	A00080...
9	1,25	90	18	33	9	7	3	7,8	A00090...	A00090...	A00090...	A00090...
10	1,5	100	20	36	10	8	3	8,5	A00100...	A00100...	A00100...	A00100...
11	1,5	100	22	-	8	6,2	3	9,5	A00110...	A00110...	A00110...	
12	1,75	110	24	-	9	7	4	10,2	A00120...	A00120...	A00120...	A00120...
14	2	110	25	-	11	9	4	12	A00140...	A00140...	A00140...	A00140...
16	2	110	28	-	12	9	4	14	A00160...	A00160...	A00160...	A00160...
18	2,5	125	32	-	14	11	4	15,5	A00180...	A00180...	A00180...	A00180...
20	2,5	140	32	-	16	12	4	17,5	A00200...	A00200...	A00200...	A00200...
22	2,5	140	32	-	18	14,5	4	19,5	A00220...	A00220...	A00220...	A00220...
24	3	160	36	-	18	14,5	4	21	A00240...	A00240...	A00240...	A00240...
27	3	160	36	-	20	16	4	24	A00270...	A00270...	A00270...	A00270...
30	3,5	180	40	-	22	18	4	26,5	A00300...	A00300...	A00300...	A00300...
33	3,5	180	40	-	25	20	5	29,5	A00330...		A00330...	
36	4	200	55	-	28	22	5	32	A00360...		A00360...	





A15 S
BRIGHT

A SERIES

DIN 376

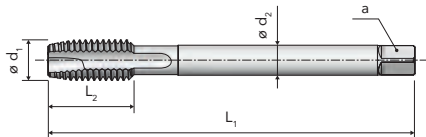

APPLICATION RANGE - CUTTING SPEED m/min

ISO	MG	A15 S BRIGHT			
P	P.2	• 20-25			
	P.3	• 15-20			
	P.4	• 12-15			
K	K.2	• 15-20			
N	N.2-3	• 20-25			
	N.6	• 15-18			



$\varnothing d_1$	P	L_1 js 16	L_2	L_3	$\varnothing d_2$ h9	a h12	Z		A15 S BRIGHT ...0152B2AA0
[mm]	[mm]	[mm]	[mm]	[mm]	[mm]	[mm]	[-]	[mm]	
M 39	4	200	60	-	32	24	5	35	A00390...
42	4,5	200	60	-	32	24	5	37,5	A00420...
45	4,5	220	65	-	36	29	5	40,5	A00450...
48	5	250	70	-	36	29	5	43	A00480...
52	5	250	70	-	40	32	5	47	A00520...



A15 S 4H
BRIGHT

A15 S 4H
TiN

DIN 371
≤ M10

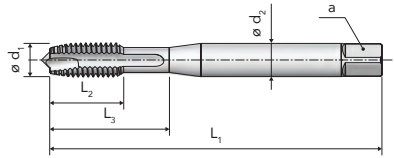

DIN 376
≥ M12

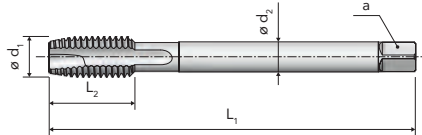

A SERIES

APPLICATION RANGE - CUTTING SPEED m/min

ISO	MG	A15 S 4H BRIGHT	A15 S 4H TiN		
P	P.2	• 20-25	• 30-35		
	P.3	• 15-20	• 25-30		
	P.4	• 12-15	• 20-25		
	P.5		• 10-15		
	P.7		• 8-10		
M	M.1		• 8-10		
K	K.2	• 15-20	• 25-30		
N	N.2-3	• 20-25	• 30-35		
	N.6	• 15-18	• 25-30		



$\varnothing d_1$	P	L_1 js16	L_2	L_3	$\varnothing d_2$ h9	a h12	Z		A15 S 4H BRIGHT ...0152B2BA0	A15 S 4H TiN ...0152B2BDO
[mm]	[mm]	[mm]	[mm]	[mm]	[mm]	[mm]	[-]	[mm]		
M 2	0,4	45	7	11	2,8	2,1	2	1,6	A00020...	A00020...
2,5	0,45	50	9	15	2,8	2,1	3	2,05	A00025...	A00025...
3	0,5	56	10	18	3,5	2,7	3	2,5	A00030...	A00030...
4	0,7	63	12	21	4,5	3,4	3	3,3	A00040...	A00040...
5	0,8	70	14	24,5	6	4,9	3	4,2	A00050...	A00050...
6	1	80	16	29	6	4,9	3	5	A00060...	A00060...
8	1,25	90	18	33	8	6,2	3	6,8	A00080...	A00080...
10	1,5	100	20	36	10	8	3	8,5	A00100...	A00100...
12	1,75	110	24	-	9	7	4	10,2	A00120...	A00120...
14	2	110	25	-	11	9	4	12	A00140...	A00140...
16	2	110	28	-	12	9	4	14	A00160...	A00160...



A15 S 6G
BRIGHT

A15 S 6G
TiN

A SERIES

DIN 371
≤ M10

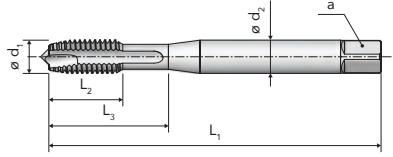

DIN 376
≥ M12

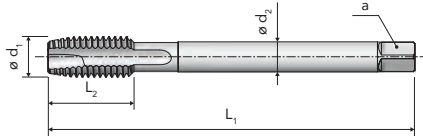

APPLICATION RANGE - CUTTING SPEED m/min

ISO	MG	A15 S 6G BRIGHT	A15 S 6G TiN
P	P.2	• 20-25	• 30-35
	P.3	• 15-20	• 25-30
	P.4	• 12-15	• 20-25
	P.5		• 10-15
	P.7		• 8-10
M	M.1		• 8-10
K	K.2	• 15-20	• 25-30
N	N.2-3	• 20-25	• 30-35
	N.6	• 15-18	• 25-30



Ød ₁	P	L ₁ js 16	L ₂	L ₃	Ød ₂ h9	a h12	Z		A15 S 6G BRIGHT ...0152B2CA0	A15 S 6G TiN ...0152B2CDD0
[mm]	[mm]	[mm]	[mm]	[mm]	[mm]	[mm]	[-]	[mm]		
M 2	0,4	45	7	11	2,8	2,1	2	1,6	A00020...	A00020...
2,5	0,45	50	9	15	2,8	2,1	3	2,05	A00025...	A00025...
3	0,5	56	10	18	3,5	2,7	3	2,5	A00030...	A00030...
4	0,7	63	12	21	4,5	3,4	3	3,3	A00040...	A00040...
5	0,8	70	14	24,5	6	4,9	3	4,2	A00050...	A00050...
6	1	80	16	29	6	4,9	3	5	A00060...	A00060...
8	1,25	90	18	33	8	6,2	3	6,8	A00080...	A00080...
10	1,5	100	20	36	10	8	3	8,5	A00100...	A00100...
12	1,75	110	24	-	9	7	4	10,2	A00120...	A00120...
14	2	110	25	-	11	9	4	12	A00140...	A00140...
16	2	110	28	-	12	9	4	14	A00160...	A00160...



A15 S 7G
BRIGHT

A15 S 7G
TiN

DIN 371
≤ M10

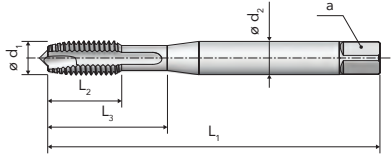

DIN 376
≥ M12

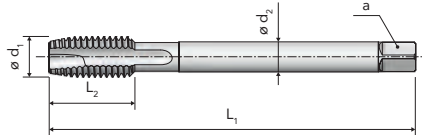

A SERIES

APPLICATION RANGE - CUTTING SPEED m/min

ISO	MG	A15 S 7G BRIGHT	A15 S 7G TiN
P	P.2	• 20-25	• 30-35
	P.3	• 15-20	• 25-30
	P.4	• 12-15	• 20-25
	P.5		• 10-15
	P.7		• 8-10
M	M.1		• 8-10
K	K.2	• 15-20	• 25-30
N	N.2-3	• 20-25	• 30-35
	N.6	• 15-18	• 25-30

7G

7G



Ød ₁	P	L ₁ js16	L ₂	L ₃	Ød ₂ h9	a h12	Z		A15 S 7G BRIGHT ...0152B2DA0	A15 S 7G TiN ...0152B2DD0
[mm]	[mm]	[mm]	[mm]	[mm]	[mm]	[mm]	[-]	[mm]		
M 3	0,5	56	10	18	3,5	2,7	3	2,5	A00030...	A00030...
4	0,7	63	12	21	4,5	3,4	3	3,3	A00040...	A00040...
5	0,8	70	14	24,5	6	4,9	3	4,2	A00050...	A00050...
6	1	80	16	29	6	4,9	3	5	A00060...	A00060...
8	1,25	90	18	33	8	6,2	3	6,8	A00080...	A00080...
10	1,5	100	20	36	10	8	3	8,5	A00100...	A00100...
12	1,75	110	24	-	9	7	4	10,2	A00120...	A00120...
14	2	110	25	-	11	9	4	12	A00140...	A00140...
16	2	110	28	-	12	9	4	14	A00160...	A00160...



A15 S LH
BRIGHT

A15 S LH
TiN

A SERIES

DIN 371
≤ M10

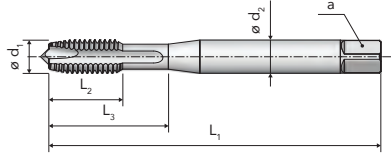

DIN 376
≥ M12

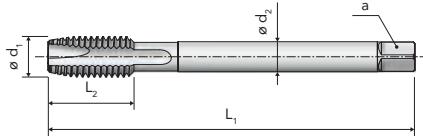

APPLICATION RANGE - CUTTING SPEED m/min

ISO	MG	A15 S LH BRIGHT	A15 S LH TiN
P	P.2	• 20-25	• 30-35
	P.3	• 15-20	• 25-30
	P.4	• 12-15	• 20-25
	P.5		• 10-15
	P.7		• 8-10
M	M.1		• 8-10
K	K.2	• 15-20	• 25-30
N	N.2-3	• 20-25	• 30-35
	N.6	• 15-18	• 25-30



Ød ₁	P	L ₁ js 16	L ₂	L ₃	Ød ₂ h9	a h12	Z		A15 S LH BRIGHT ...0152S2AA0	A15 S LH TiN ...0152S2AD0
[mm]	[mm]	[mm]	[mm]	[mm]	[mm]	[mm]	[-]	[mm]		
M 3	0,5	56	10	18	3,5	2,7	3	2,5	A00030...	A00030...
4	0,7	63	12	21	4,5	3,4	3	3,3	A00040...	A00040...
5	0,8	70	14	24,5	6	4,9	3	4,2	A00050...	A00050...
6	1	80	16	29	6	4,9	3	5	A00060...	A00060...
8	1,25	90	18	33	8	6,2	3	6,8	A00080...	A00080...
10	1,5	100	20	36	10	8	3	8,5	A00100...	A00100...
12	1,75	110	24	-	9	7	4	10,2	A00120...	A00120...
14	2	110	25	-	11	9	4	12	A00140...	A00140...
16	2	110	28	-	12	9	4	14	A00160...	A00160...
20	2,5	140	32	-	16	12	4	17,5	A00200...	A00200...



A16 S
BRIGHT

A16 S
TiN

DIN 376

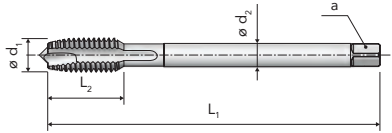

A SERIES

APPLICATION RANGE - CUTTING SPEED m/min

ISO	MG	A16 S BRIGHT	A16 S TiN
P	P.2	● 20-25	● 30-35
	P.3	● 15-20	● 25-30
	P.4	● 12-15	● 20-25
	P.5		● 10-15
	P.7		● 8-10
M	M.1		● 8-10
K	K.2	● 15-20	● 25-30
N	N.2-3	● 20-25	● 30-35
	N.6	● 15-18	● 25-30



$\varnothing d_1$	P	L_1 js16	L_2	L_3	$\varnothing d_2$ h9	a h12	z		A16 S BRIGHT ...0162B2AA0	A16 S TiN ...0162B2AD0
[mm]	[mm]	[mm]	[mm]	[mm]	[mm]	[mm]	[-]	[mm]		
M 4	0,7	63	12	-	2,8	2,1	3	3,3	A00040...	A00040...
5	0,8	70	14	-	3,5	2,7	3	4,2	A00050...	A00050...
6	1	80	16	-	4,5	3,4	3	5	A00060...	A00060...
7	1	80	16	-	5,5	4,3	3	6	A00070...	A00070...
8	1,25	90	18	-	6	4,9	3	6,8	A00080...	A00080...
9	1,25	90	18	-	7	5,5	3	7,8	A00090...	A00090...
10	1,5	100	20	-	7	5,5	3	8,5	A00100...	A00100...



A15 AZ
BRIGHT

A15 AZ
TiH1

A SERIES

DIN 371
≤ M10

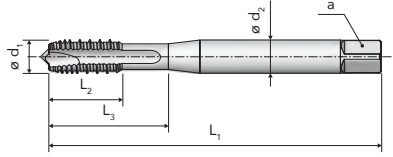

DIN 376
≥ M12

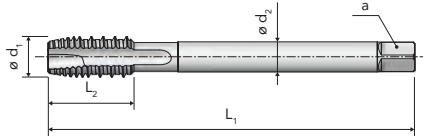

APPLICATION RANGE - CUTTING SPEED m/min

ISO	MG	A15 AZ BRIGHT	A15 AZ TiH1
P	P.1	• 18-20	• 30-35
	N.1	• 18-20	• 30-40
N	N.2	• 15-18	• 30-40
	N.5	• 15-18	• 30-35
	N.6	• 12-15	• 30-35



$\varnothing d_1$	P	L_1 js 16	L_2	L_3	$\varnothing d_2$ h9	a h12	Z		A15 AZ BRIGHT ...0152F2AA0	A15 AZ TiH1 ...0152F2AH0
[mm]	[mm]	[mm]	[mm]	[mm]	[mm]	[mm]	[-]	[mm]		
M 3	0,5	56	10	18	3,5	2,7	3	2,5	A00030...	A00030...
4	0,7	63	12	21	4,5	3,4	3	3,3	A00040...	A00040...
5	0,8	70	14	24,5	6	4,9	3	4,2	A00050...	A00050...
6	1	80	16	29	6	4,9	3	5	A00060...	A00060...
8	1,25	90	18	33	8	6,2	3	6,8	A00080...	A00080...
10	1,5	100	20	36	10	8	3	8,5	A00100...	A00100...
12	1,75	110	24	-	9	7	3	10,2	A00120...	A00120...
14	2	110	25	-	11	9	3	12	A00140...	A00140...
16	2	110	28	-	12	9	3	14	A00160...	A00160...



A15 L
BRIGHT

A15 L
TiN

NORM VERGNANO
≤ M10

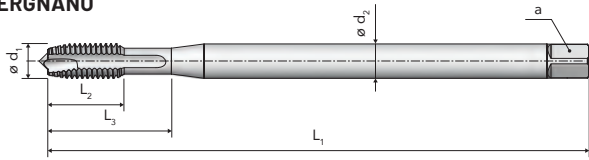

NORM VERGNANO
≥ M12

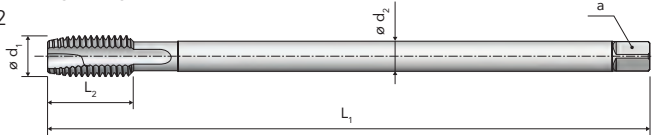

A SERIES

APPLICATION RANGE - CUTTING SPEED m/min

ISO	MG	A15 L BRIGHT	A15 L TiN
P	P.1	• 18-20	• 30-35
	P.2	• 15-18	• 25-30
	P.3	• 12-15	• 20-25
N	N.1	• 18-20	
	N.2	• 15-18	• 25-30
	N.5	• 15-18	
	N.6	• 12-15	• 20-25



Ød ₁	P	L ₁ js16	L ₂	L ₃	Ød ₂ h9	a h12	Z		A15 L BRIGHT ...0152L2AA0	A15 L TiN ...0152L2AD0
[mm]	[mm]	[mm]	[mm]	[mm]	[mm]	[mm]	[-]	[mm]		
M 2	0,4	90	7	11	2,8	2,1	2	1,6	A00020...	A00020...
2,5	0,45	100	9	15	2,8	2,1	3	2,5	A00025...	A00025...
3	0,5	112	10	18	3,5	2,7	3	2,5	A00030...	A00030...
4	0,7	112	12	21	4,5	3,4	3	3,3	A00040...	A00040...
5	0,8	125	14	24,5	6	4,9	3	4,2	A00050...	A00050...
6	1	125	16	29	6	4,9	3	5	A00060...	A00060...
8	1,25	140	18	33	8	6,2	3	6,8	A00080...	A00080...
10	1,5	160	20	36	10	8	3	8,5	A00100...	A00100...
12	1,75	180	24	-	9	7	3	10,2	A00120...	A00120...
16	2	200	28	-	12	9	3	14	A00160...	A00160...
20	2,5	225	32	-	16	12	4	17,5	A00200...	A00200...



A150
VAP

A150
TiX2

A SERIES

DIN 371
≤ M10

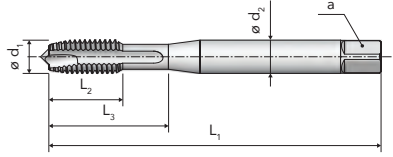

DIN 376
≥ M12

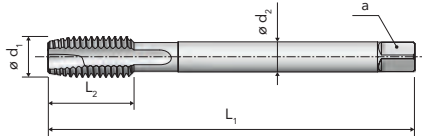

APPLICATION RANGE - CUTTING SPEED m/min

ISO	MG	A150 VAP	A150 TiX2
P	P.7	• 10-12	• 10-15
M	M.1	• 10-12	• 10-15



$\varnothing d_1$	P	L_1 js 16	L_2	L_3	$\varnothing d_2$ h9	a h12	Z		A150 VAP ...1502A2AB0	A150 TiX2 ...1502A2AL0
[mm]	[mm]	[mm]	[mm]	[mm]	[mm]	[mm]	[-]	[mm]		
M 3	0,5	56	10	18	3,5	2,7	3	2,5	A00030...	A00030...
3,5	0,6	56	11	16	4	3	3	2,9	A00035...	A00035...
4	0,7	63	12	21	4,5	3,4	3	3,3	A00040...	A00040...
5	0,8	70	14	24,5	6	4,9	3	4,2	A00050...	A00050...
6	1	80	16	29	6	4,9	3	5	A00060...	A00060...
8	1,25	90	18	33	8	6,2	3	6,8	A00080...	A00080...
10	1,5	100	20	36	10	8	3	8,5	A00100...	A00100...
12	1,75	110	24	-	9	7	3	10,2	A00120...	A00120...
14	2	110	25	-	11	9	3	12	A00140...	A00140...
16	2	110	28	-	12	9	3	14	A00160...	A00160...
18	2,5	125	32	-	14	11	4	15,5	A00180...	A00180...
20	2,5	140	32	-	16	12	4	17,5	A00200...	A00200...



A29
BRIGHT

A29
VAP

A29
TiN

DIN 371
≤ M10

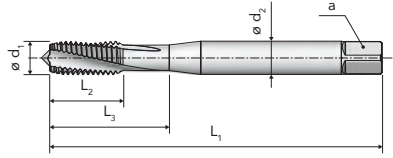

DIN 376
≥ M11

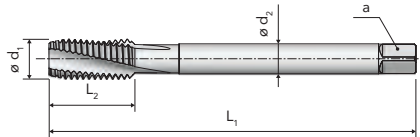

A SERIES

APPLICATION RANGE - CUTTING SPEED m/min

ISO	MG	A29 BRIGHT	A29 VAP	A29 TiN
P	P.1	• 18-20	• 18-20	• 30-35
	P.2	• 15-18	• 15-18	• 25-30
	P.3	• 12-15	• 12-15	• 20-25
	P.4	• 10-12	• 10-12	• 15-20
	P.5			• 5-10
K	K.2	• 12-15	• 12-15	• 20-25
N	N.1	• 18-20	• 18-20	
	N.2-3	• 15-18	• 15-18	• 25-30
	N.5	• 15-18	• 15-18	
	N.6	• 12-15	• 12-15	• 20-25



$\varnothing d_1$	P	L_1 js16	L_2	L_3	$\varnothing d_2$ h9	a h12	z		A29 BRIGHT ...0292A1AA0	A29 VAP ...0292A1AB0	A29 TiN ...0292A1AD0
[mm]	[mm]	[mm]	[mm]	[mm]	[mm]	[mm]	[-]	[mm]			
M2	0,4	45	7	11	2,8	2,1	3	1,6	A00020...	A00020...	A00020...
2,2	0,45	45	8	13	2,8	2,1	3	1,75	A00022...		
2,3	0,4	45	8	13	2,8	2,1	3	1,9	A00023...		
2,5	0,45	50	9	15	2,8	2,1	3	2,05	A00025...	A00025...	A00025...
2,6	0,45	50	9	15	2,8	2,1	3	2,1	A00026...		
3	0,5	56	10	18	3,5	2,7	3	2,5	A00030...	A00030...	A00030...
3,5	0,6	56	11	20	4	3	3	2,9	A00035...	A00035...	A00035...
4	0,7	63	12	21	4,5	3,4	3	3,3	A00040...	A00040...	A00040...
4,5	0,75	70	14	24,5	6	4,9	3	3,7	A00045...		
5	0,8	70	14	24,5	6	4,9	3	4,2	A00050...	A00050...	A00050...
6	1	80	16	29	6	4,9	3	5	A00060...	A00060...	A00060...
7	1	80	16	29	7	5,5	3	6	A00070...	A00070...	A00070...
8	1,25	90	18	33	8	6,2	3	6,8	A00080...	A00080...	A00080...
9	1,25	90	18	33	9	7	3	7,8	A00090...	A00090...	A00090...
10	1,5	100	20	36	10	8	3	8,5	A00100...	A00100...	A00100...
11	1,5	100	22	-	8	6,2	3	9,5	A00110...		
12	1,75	110	24	-	9	7	3	10,2	A00120...	A00120...	A00120...
14	2	110	25	-	11	9	3	12	A00140...	A00140...	A00140...
16	2	110	28	-	12	9	3	14	A00160...	A00160...	A00160...
18	2,5	125	32	-	14	11	3	15,5	A00180...	A00180...	A00180...
20	2,5	140	32	-	16	12	4	17,5	A00200...	A00200...	A00200...
22	2,5	140	32	-	18	14,5	4	19,5	A00220...	A00220...	A00220...
24	3	160	36	-	18	14,5	4	21	A00240...	A00240...	A00240...
27	3	160	36	-	20	16	4	24	A00270...	A00270...	A00270...
30	3,5	180	40	-	22	18	4	26,5	A00300...	A00300...	A00300...
33	3,5	180	40	-	25	20	5	29,5	A00330...	A00330...	A00330...





A29
BRIGHT

A SERIES

DIN 376

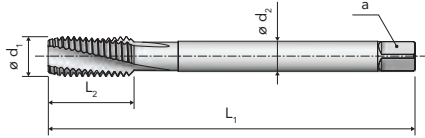

APPLICATION RANGE - CUTTING SPEED m/min

ISO	MG	A29 BRIGHT			
P	P.1	• 18-20			
	P.2	• 15-18			
	P.3	• 12-15			
	P.4	• 10-12			
K	K.2	• 12-15			
N	N.1	• 18-20			
	N.2-3	• 15-18			
	N.5	• 15-18			
	N.6	• 12-15			



<<

$\varnothing d_1$	P	L_1 js 16	L_2	L_3	$\varnothing d_2$ h9	a h12	Z		A29 BRIGHT ...0292A1AA0
[mm]	[mm]	[mm]	[mm]	[mm]	[mm]	[mm]	[-]	[mm]	
M 36	4	200	55	-	28	22	5	32	A00360...
39	4	200	60	-	32	24	5	35	A00390...
42	4,5	200	60	-	32	24	5	37,5	A00420...
45	4,5	220	65	-	36	29	5	40,5	A00450...
48	5	250	70	-	36	29	5	43	A00480...
52	5	250	70	-	40	32	5	47	A00520...



A29 6G
BRIGHT

A29 6G
TiN

DIN 371
≤ M10

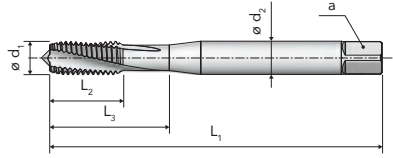

DIN 376
≥ M12

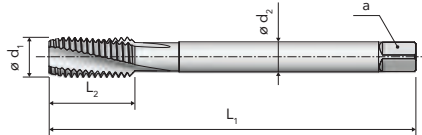

A SERIES

APPLICATION RANGE - CUTTING SPEED m/min

ISO	MG	A29 6G BRIGHT	A29 6G TiN
P	P.1	• 18-20	• 30-35
	P.2	• 15-18	• 25-30
	P.3	• 12-15	• 20-25
	P.4	• 10-12	• 15-20
	P.5		• 5-10
K	K.2	• 12-15	• 20-25
N	N.1	• 18-20	
	N.2-3	• 15-18	• 25-30
	N.5	• 15-18	
	N.6	• 12-15	• 20-25



Ød ₁	P	L ₁ js16	L ₂	L ₃	Ød ₂ h9	a h12	Z	z	A29 6G BRIGHT ...0292A1CA0	A29 6G TiN ...0292A1CDO
[mm]	[mm]	[mm]	[mm]	[mm]	[mm]	[mm]	[-]	[mm]		
M 2	0,4	45	7	11	2,8	2,1	3	1,6	A00020...	A00020...
2,5	0,45	50	9	15	2,8	2,1	3	2,05	A00025...	A00025...
3	0,5	56	10	18	3,5	2,7	3	2,5	A00030...	A00030...
4	0,7	63	12	21	4,5	3,4	3	3,3	A00040...	A00040...
5	0,8	70	14	24,5	6	4,9	3	4,2	A00050...	A00050...
6	1	80	16	29	6	4,9	3	5	A00060...	A00060...
8	1,25	90	18	33	8	6,2	3	6,8	A00080...	A00080...
10	1,5	100	20	36	10	8	3	8,5	A00100...	A00100...
12	1,75	110	24	-	9	7	3	10,2	A00120...	A00120...
14	2	110	25	-	11	9	3	12	A00140...	A00140...

A29 DIN 376
BRIGHTA29 DIN 376
TiN

DIN 376

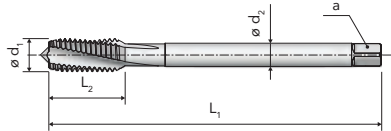

APPLICATION RANGE - CUTTING SPEED m/min

ISO	MG	A29 DIN 376	A29 DIN 376		
		BRIGHT	TiN		
P	P.1	• 18-20	• 30-35		
	P.2	• 15-18	• 25-30		
	P.3	• 12-15	• 20-25		
	P.4	• 10-12	• 15-20		
	P.5		• 5-10		
K	K.2	• 12-15	• 20-25		
N	N.1	• 18-20			
	N.2-3	• 15-18	• 25-30		
	N.5	• 15-18			
	N.6	• 12-15	• 20-25		

ISO2
6HISO2
6H

$\varnothing d_1$	P	L_1 js 16	L_2	L_3	$\varnothing d_2$ h9	a h12	Z		A29 DIN 376 BRIGHT ...0292D1AA0	A29 DIN 376 TiN ...0292D1AD0
[mm]	[mm]	[mm]	[mm]	[mm]	[mm]	[mm]	[-]	[mm]		
M 5	0,8	70	14	-	3,5	2,7	3	4,2	A00050...	A00050...
6	1	80	16	-	4,5	3,4	3	5	A00060...	A00060...
8	1,25	90	18	-	6	4,9	3	6,8	A00080...	A00080...
10	1,5	100	20	-	7	5,5	3	8,5	A00100...	A00100...



A29 L
BRIGHT

A29 L
TiN

NORM VERGNANO
≤ M10

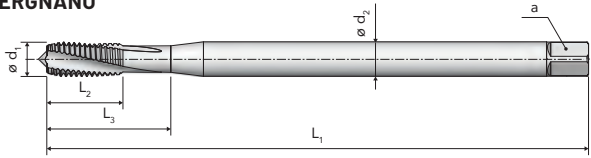

NORM VERGNANO
≥ M12

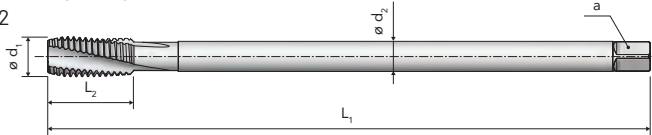

A SERIES

APPLICATION RANGE - CUTTING SPEED m/min

ISO	MG	A29 L BRIGHT	A29 L TiN
P	P.1	• 18-20	• 30-35
	P.2	• 15-18	• 25-30
	P.3	• 12-15	• 20-25
	P.4	• 10-12	• 15-20
	P.5		• 5-10
K	K.2	• 12-15	• 20-25
N	N.1	• 18-20	
	N.2-3	• 15-18	• 25-30
	N.5	• 15-18	
	N.6	• 12-15	• 20-25

ISO2
6H

ISO2
6H



Ød ₁	P	L ₁ js16	L ₂	L ₃	Ød ₂ h9	a h12	Z	z	A29 L BRIGHT ...0292L1AA0	A29 L TiN ...0292L1AD0
[mm]	[mm]	[mm]	[mm]	[mm]	[mm]	[mm]	[-]	[mm]		
M 4	0,7	112	12	21	4,5	3,4	3	3,3	A00040...	A00040...
5	0,8	125	14	24,5	6	4,9	3	4,2	A00050...	A00050...
6	1	125	16	29	6	4,9	3	5	A00060...	A00060...
8	1,25	140	18	33	8	6,2	3	6,8	A00080...	A00080...
10	1,5	160	20	36	10	8	3	8,5	A00100...	A00100...
12	1,75	180	24	-	9	7	3	10,2	A00120...	A00120...



A70 S
BRIGHT

A70 S
VAP

A70 S
TiN

A70 S
TiCN

A SERIES

DIN 371
≤ M10

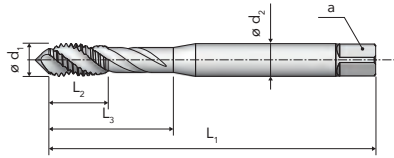

DIN 376
≥ M11

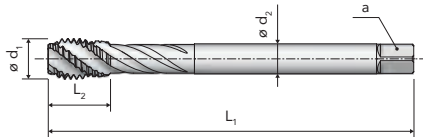

APPLICATION RANGE - CUTTING SPEED m/min

ISO	MG	A70 S BRIGHT	A70 S VAP	A70 S TiN	A70 S TiCN
P	P.2	● 15-20	● 15-20	● 25-30	● 25-30
	P.3	● 12-15	● 12-15	● 20-25	● 20-25
	P.4	● 10-12	● 10-12	● 15-20	● 15-20
	P.5			● 5-10	● 5-10
	P.7			● 6-8	● 6-8
M	M.1			● 6-8	● 6-8
K	K.2	● 12-15	● 12-15	● 20-25	● 20-25
N	N.3	● 15-18	● 15-18	● 25-30	● 25-30
	N.6	● 15-18	● 15-18	● 25-30	● 25-30



Ød ₁	P	L ₁ js 16	L ₂	L ₃	Ød ₂ h9	a h12	Z		A70 S BRIGHT ...0702B1AA0	A70 S VAP ...0702B1AB0	A70 S TiN ...0702B1AD0	A70 S TiCN ...0702B1AE0
[mm]	[mm]	[mm]	[mm]	[mm]	[mm]	[mm]	[-]	[mm]				
M 2	0,4	45	6	12	2,8	2,1	3	1,6	A00020...	A00020...	A00020...	A00020...
2,5	0,45	50	6,5	15	2,8	2,1	3	2,05	A00025...	A00025...	A00025...	A00025...
3	0,5	56	7	15	3,5	2,7	3	2,5	A00030...	A00030...	A00030...	A00030...
3,5	0,6	56	8	18,5	4	3	3	2,9	A00035...	A00035...	A00035...	A00035...
4	0,7	63	8,5	21	4,5	3,4	3	3,3	A00040...	A00040...	A00040...	A00040...
5	0,8	70	10	24,5	6	4,9	3	4,2	A00050...	A00050...	A00050...	A00050...
6	1	80	12	29	6	4,9	3	5	A00060...	A00060...	A00060...	A00060...
7	1	80	12	29	7	5,5	3	6	A00070...	A00070...	A00070...	A00070...
8	1,25	90	15	33	8	6,2	3	6,8	A00080...	A00080...	A00080...	A00080...
9	1,25	90	15	33	9	7	3	7,8	A00090...	A00090...	A00090...	A00090...
10	1,5	100	17,5	38	10	8	3	8,5	A00100...	A00100...	A00100...	A00100...
11	1,5	100	17,5	-	8	6,2	3	9,5	A00110...	A00110...	A00110...	A00110...
12	1,75	110	18	-	9	7	4	10,2	A00120...	A00120...	A00120...	A00120...
14	2	110	20,5	-	11	9	4	12	A00140...	A00140...	A00140...	A00140...
16	2	110	20,5	-	12	9	4	14	A00160...	A00160...	A00160...	A00160...
18	2,5	125	25,5	-	14	11	4	15,5	A00180...	A00180...	A00180...	A00180...
20	2,5	140	29,5	-	16	12	4	17,5	A00200...	A00200...	A00200...	A00200...
22	2,5	140	29,5	-	18	14,5	4	19,5	A00220...	A00220...	A00220...	A00220...
24	3	160	35,5	-	18	14,5	4	21	A00240...	A00240...	A00240...	A00240...
27	3	160	37,5	-	20	16	5	24	A00270...	A00270...	A00270...	A00270...
30	3,5	180	42	-	22	18	5	26,5	A00300...	A00300...	A00300...	A00300...
33	3,5	180	43,5	-	25	20	5	29,5	A00330...	A00330...	A00330...	
36	4	200	47	-	28	22	5	32	A00360...	A00360...	A00360...	
42	4,5	200	55	-	32	24	6	37,5	A00420...			
48	5	250	59,5	-	36	29	6	43	A00480...			
52	5	250	59,5	-	40	32	6	47	A00520...			



A70 S 4H
BRIGHT

A70 S 4H
TiN

DIN 371
≤ M10

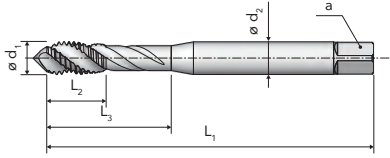

DIN 376
≥ M12

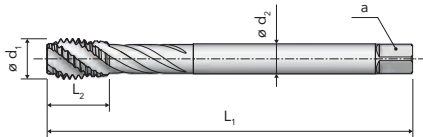

A SERIES

APPLICATION RANGE - CUTTING SPEED m/min

ISO	MG	A70 S 4H BRIGHT	A70 S 4H TiN
P	P.2	● 15-20	● 25-30
	P.3	● 12-15	● 20-25
	P.4	● 10-12	● 15-20
	P.5		● 5-10
	P.7		● 6-8
M	M.1		● 6-8
K	K.2	● 12-15	● 20-25
N	N.3	● 15-18	● 25-30
	N.6	● 15-18	● 25-30



$\varnothing d_1$	P	L_1 js16 [mm]	L_2 [mm]	L_3 [mm]	$\varnothing d_2$ h9 [mm]	a h12 [mm]	Z		A70 S 4H BRIGHT ...0702B1BA0	A70 S 4H TiN ...0702B1BD0
[mm]	[mm]	[mm]	[mm]	[mm]	[mm]	[mm]	[-]	[mm]		
M2	0,4	45	6	12	2,8	2,1	3	1,6	A00020...	A00020...
2,5	0,45	50	6,5	15	2,8	2,1	3	2,05	A00025...	A00025...
3	0,5	56	7	15	3,5	2,7	3	2,5	A00030...	A00030...
4	0,7	63	8,5	21	4,5	3,4	3	3,3	A00040...	A00040...
5	0,8	70	10	24,5	6	4,9	3	4,2	A00050...	A00050...
6	1	80	12	29	6	4,9	3	5	A00060...	A00060...
8	1,25	90	15	33	8	6,2	3	6,8	A00080...	A00080...
10	1,5	100	17,5	38	10	8	3	8,5	A00100...	A00100...
12	1,75	110	18	-	9	7	4	10,2	A00120...	A00120...



A70 S 6G
BRIGHT

A70 S 6G
TiN

A SERIES

DIN 371
≤ M10

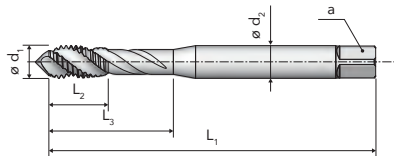

DIN 376
≥ M12

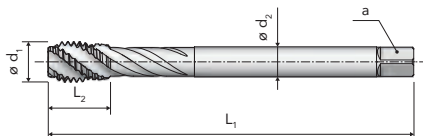

APPLICATION RANGE - CUTTING SPEED m/min

ISO	MG	A70 S 6G BRIGHT	A70 S 6G TiN
P	P.2	● 15-20	● 25-30
	P.3	● 12-15	● 20-25
	P.4	● 10-12	● 15-20
	P.5		● 5-10
	P.7		● 6-8
M	M.1		● 6-8
K	K.2	● 12-15	● 20-25
N	N.3	● 15-18	● 25-30
	N.6	● 15-18	● 25-30



Ød ₁	P	L ₁ js 16	L ₂	L ₃	Ød ₂ h9	a h12	Z		A70 S 6G BRIGHT ...0702B1CA0	A70 S 6G TiN ...0702B1C00
[mm]	[mm]	[mm]	[mm]	[mm]	[mm]	[mm]	[-]	[mm]		
M 3	0,5	56	7	15	3,5	2,7	3	2,5	A00030...	A00030...
4	0,7	63	8,5	21	4,5	3,4	3	3,3	A00040...	A00040...
5	0,8	70	10	24,5	6	4,9	3	4,2	A00050...	A00050...
6	1	80	12	29	6	4,9	3	5	A00060...	A00060...
8	1,25	90	15	33	8	6,2	3	6,8	A00080...	A00080...
10	1,5	100	17,5	38	10	8	3	8,5	A00100...	A00100...
12	1,75	110	18	-	9	7	4	10,2	A00120...	A00120...
14	2	110	20,5	-	11	9	4	12	A00140...	A00140...
16	2	110	20,5	-	12	9	4	14	A00160...	A00160...



A70 S 7G
BRIGHT

A70 S 7G
TiN

DIN 371
≤ M10

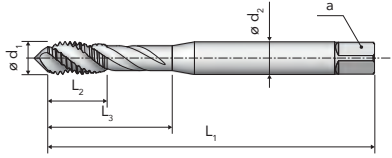

DIN 376
≥ M12

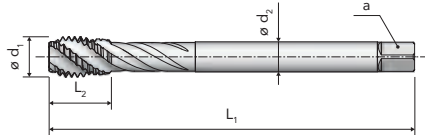

A SERIES

APPLICATION RANGE - CUTTING SPEED m/min

ISO	MG	A70 S 7G BRIGHT	A70 S 7G TiN
P	P.2	• 15-20	• 25-30
	P.3	• 12-15	• 20-25
	P.4	• 10-12	• 15-20
	P.5		• 5-10
	P.7		• 6-8
M	M.1		• 6-8
K	K.2	• 12-15	• 20-25
N	N.3	• 15-18	• 25-30
	N.6	• 15-18	• 25-30



Ød ₁	P	L ₁ js16	L ₂	L ₃	Ød ₂ h9	a h12	Z		A70 S 7G BRIGHT ...0702B1DA0	A70 S 7G TiN ...0702B1DD0
[mm]	[mm]	[mm]	[mm]	[mm]	[mm]	[mm]	[-]	[mm]		
M 3	0,5	56	7	15	3,5	2,7	3	2,5	A00030...	A00030...
4	0,7	63	8,5	21	4,5	3,4	3	3,3	A00040...	A00040...
5	0,8	70	10	24,5	6	4,9	3	4,2	A00050...	A00050...
6	1	80	12	29	6	4,9	3	5	A00060...	A00060...
8	1,25	90	15	33	8	6,2	3	6,8	A00080...	A00080...
10	1,5	100	17,5	38	10	8	3	8,5	A00100...	A00100...
12	1,75	110	18	-	9	7	4	10,2	A00120...	A00120...
14	2	110	20,5	-	11	9	4	12	A00140...	A00140...
16	2	110	20,5	-	12	9	4	14	A00160...	A00160...



A701S
BRIGHT

A701S
TiN

A SERIES

DIN 371
≤ M10

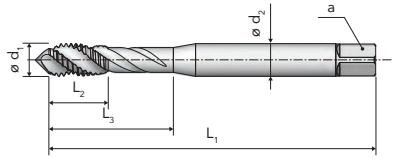

DIN 376
≥ M12

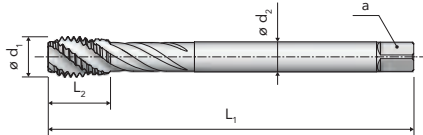

APPLICATION RANGE - CUTTING SPEED m/min

ISO	MG	A701S BRIGHT	A701S TiN
P	P.2	● 15-20	● 25-30
	P.3	● 12-15	● 20-25
	P.4	● 10-12	● 15-20
	P.5		● 5-10
	P.7		● 6-8
M	M.1		● 6-8
K	K.2	● 12-15	● 20-25
N	N.3	● 15-18	● 25-30
	N.6	● 15-18	● 25-30



Ød ₁	P	L ₁ js 16	L ₂	L ₃	Ød ₂ h9	a h12	Z		A701S BRIGHT ...7012B1EA0	A701S TiN ...7012B1ED0
[mm]	[mm]	[mm]	[mm]	[mm]	[mm]	[mm]	[-]	[mm]		
M 4	0,7	63	8,5	21	4,5	3,4	3	3,3	A00040...	A00040...
5	0,8	70	10	24,5	6	4,9	3	4,2	A00050...	A00050...
6	1	80	12	29	6	4,9	3	5	A00060...	A00060...
8	1,25	90	15	33	8	6,2	3	6,8	A00080...	A00080...
10	1,5	100	17,5	38	10	8	3	8,5	A00100...	A00100...
12	1,75	110	18	-	9	7	4	10,2	A00120...	A00120...
14	2	110	20,5	-	11	9	4	12	A00140...	A00140...
16	2	110	20,5	-	12	9	4	14	A00160...	A00160...



A70 SE
BRIGHT

A70 SE
TiN

DIN 371
≤ M10

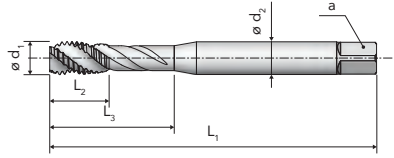

DIN 376
≥ M12

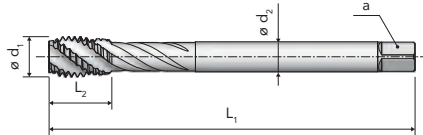

APPLICATION RANGE - CUTTING SPEED m/min

ISO	MG	A70 SE BRIGHT	A70 SE TiN
P	P.2	• 15-20	• 25-30
	P.3	• 12-15	• 20-25
	P.4	• 10-12	• 15-20
	P.5		• 5-10
	P.7		• 6-8
M	M.1		• 6-8
K	K.2	• 12-15	• 20-25
N	N.3	• 15-18	• 25-30
	N.6	• 15-18	• 25-30



Ød ₁	P	L ₁ js16	L ₂	L ₃	Ød ₂ h9	a h12	Z		A70 SE BRIGHT ...0702B3AA0	A70 SE TiN ...0702B3AD0
[mm]	[mm]	[mm]	[mm]	[mm]	[mm]	[mm]	[-]	[mm]		
M 3	0,5	56	7	15	3,5	2,7	3	2,5	A00030...	A00030...
4	0,7	63	8,5	21	4,5	3,4	3	3,3	A00040...	A00040...
5	0,8	70	10	24,5	6	4,9	3	4,2	A00050...	A00050...
6	1	80	12	29	6	4,9	3	5	A00060...	A00060...
8	1,25	90	15	33	8	6,2	3	6,8	A00080...	A00080...
10	1,5	100	17,5	38	10	8	3	8,5	A00100...	A00100...
12	1,75	110	18	-	9	7	4	10,2	A00120...	A00120...
16	2	110	20,5	-	12	9	4	14	A00160...	A00160...

A SERIES



A70 SLH
BRIGHT

A70 SLH
TiN

A SERIES

DIN 371
≤ M10

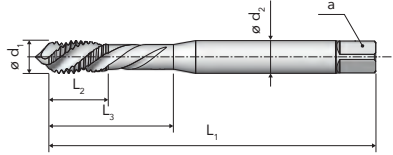

DIN 376
≥ M12

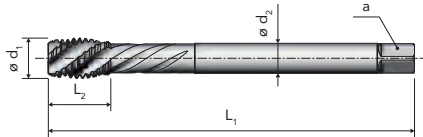

APPLICATION RANGE - CUTTING SPEED m/min

ISO	MG	A70 SLH BRIGHT	A70 SLH TiN
P	P.2	• 15-20	• 25-30
	P.3	• 12-15	• 20-25
	P.4	• 10-12	• 15-20
	P.5		• 5-10
	P.7		• 6-8
M	M.1		• 6-8
K	K.2	• 12-15	• 20-25
N	N.3	• 15-18	• 25-30
	N.6	• 15-18	• 25-30



Ød ₁	P	L ₁ js 16	L ₂	L ₃	Ød ₂ h9	a h12	Z	Φ	A70 SLH BRIGHT ...0702S1AA0	A70 SLH TiN ...0702S1AD0
[mm]	[mm]	[mm]	[mm]	[mm]	[mm]	[mm]	[-]	[mm]		
M3	0,5	56	7	15	3,5	2,7	3	2,5	A00030...	A00030...
4	0,7	63	8,5	21	4,5	3,4	3	3,3	A00040...	A00040...
5	0,8	70	10	24,5	6	4,9	3	4,2	A00050...	A00050...
6	1	80	12	29	6	4,9	3	5	A00060...	A00060...
8	1,25	90	15	33	8	6,2	3	6,8	A00080...	A00080...
10	1,5	100	17,5	38	10	8	3	8,5	A00100...	A00100...
12	1,75	110	18	-	9	7	4	10,2	A00120...	A00120...
14	2	110	20,5	-	11	9	4	12	A00140...	A00140...
16	2	110	20,5	-	12	9	4	14	A00160...	A00160...
20	2,5	140	29,5	-	16	12	4	17,5	A00200...	A00200...
22	2,5	140	29,5	-	18	14,5	4	19,5	A00220...	A00220...
24	3	160	35,5	-	18	14,5	4	21	A00240...	A00240...
27	3	160	37,5	-	20	16	5	24	A00270...	A00270...
30	3,5	180	42	-	22	18	5	26,5	A00300...	A00300...



A76 S
BRIGHT

A76 S
TiN

DIN 376

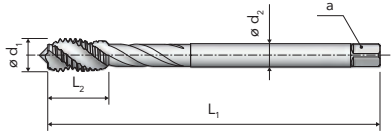

A SERIES

APPLICATION RANGE - CUTTING SPEED m/min

ISO	MG	A76 S BRIGHT	A76 S TiN
P	P.2	• 15-20	• 25-30
	P.3	• 12-15	• 20-25
	P.4	• 10-12	• 15-20
	P.5		• 5-10
	P.7		• 6-8
M	M.1		• 6-8
K	K.2	• 12-15	• 20-25
N	N.3	• 15-18	• 25-30
	N.6	• 15-18	• 25-30



$\varnothing d_1$	P	L_1 js16	L_2	L_3	$\varnothing d_2$ h9	a h12	z		A76 S BRIGHT ...0762B1AA0	A76 S TiN ...0762B1AD0
[mm]	[mm]	[mm]	[mm]	[mm]	[mm]	[mm]	[-]	[mm]		
M 4	0,7	64	6,4	-	2,8	2,1	3	3,3	A00040...	A00040...
5	0,8	70	8,1	-	3,5	2,7	3	4,2	A00050...	A00050...
6	1	80	12	-	4,5	3,4	3	5	A00060...	A00060...
8	1,25	90	15	-	6	4,9	3	6,8	A00080...	A00080...
10	1,5	100	17,5	-	7	5,5	3	8,5	A00100...	A00100...



A70 L
BRIGHT

A70 L
TiN

A SERIES

NORM VERGNANO

≤ M10

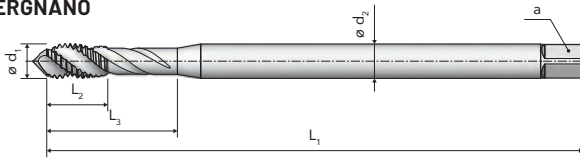

NORM VERGNANO

≥ M12

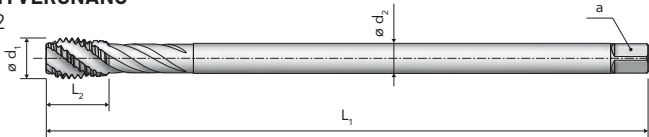

APPLICATION RANGE - CUTTING SPEED m/min

ISO	MG	A70 L BRIGHT	A70 L TiN
P	P.1	• 12-15	• 25-30
	P.2	• 10-15	• 20-25
N	N.1	• 12-15	
	N.2	• 12-15	• 25-30
	N.5	• 10-12	
	N.6	• 10-12	• 20-25



Ød ₁	P	L ₁ js 16	L ₂	L ₃	Ød ₂ h9	a h12	Z		A70 L BRIGHT ...0702L1AA0	A70 L TiN ...0702L1ADO
[mm]	[mm]	[mm]	[mm]	[mm]	[mm]	[mm]	[-]	[mm]		
M 2	0,4	90	6	12	2,8	2,1	3	1,6	A00020...	A00020...
2,5	0,45	100	6,5	15	2,8	2,1	3	2,05	A00025...	A00025...
3	0,5	112	7	15	3,5	2,7	3	2,5	A00030...	A00030...
4	0,7	112	8,5	21	4,5	3,4	3	3,3	A00040...	A00040...
5	0,8	125	10	24,5	6	4,9	3	4,2	A00050...	A00050...
6	1	125	12	29	6	4,9	3	5	A00060...	A00060...
8	1,25	140	15	33	8	6,2	3	6,8	A00080...	A00080...
10	1,5	160	17,5	38	10	8	3	8,5	A00100...	A00100...
12	1,75	180	18	-	9	7	4	10,2	A00120...	A00120...
16	2	200	20,5	-	12	9	4	14	A00160...	A00160...
20	2,5	225	29,5	-	16	12	4	17,5	A00200...	A00200...



A120
BRIGHT

A120
VAP

A120
TiN

DIN 371
≤ M10

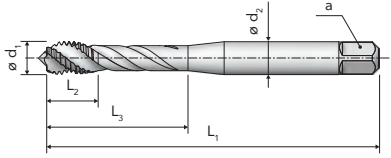

DIN 376
≥ M12

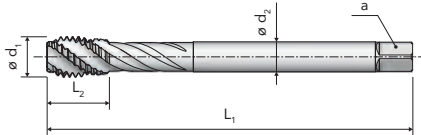

A SERIES

APPLICATION RANGE - CUTTING SPEED m/min

ISO	MG	A120 BRIGHT	A120 VAP	A120 TiN
P	P.1	• 12-15	• 12-15	• 25-30
	P.2	• 10-15	• 10-15	• 20-25
N	N.1	• 12-15	• 12-15	
	N.2	• 12-15	• 12-15	• 25-30
	N.5	• 10-12	• 10-12	
	N.6	• 10-12	• 10-12	• 20-25



Ød ₁	P	L ₁ js16	L ₂	L ₃	Ød ₂ h9	a h12	z		A120 BRIGHT ...1202A1AA0	A120 VAP ...1202A1AB0	A120 TiN ...1202A1AD0
[mm]	[mm]	[mm]	[mm]	[mm]	[mm]	[mm]	[-]	[mm]			
M 2	0,4	45	6	14	2,8	2,1	3	1,6	A00020...	A00020...	A00020...
2,5	0,45	50	6	18	2,8	2,1	3	2,05	A00025...	A00025...	A00025...
3	0,5	56	6	21	3,5	2,7	3	2,5	A00030...	A00030...	A00030...
4	0,7	63	6,5	27	4,5	3,4	3	3,3	A00040...	A00040...	A00040...
5	0,8	70	8	30	6	4,9	3	4,2	A00050...	A00050...	A00050...
6	1	80	9	34,5	6	4,9	3	5	A00060...	A00060...	A00060...
8	1,25	90	12	38,5	8	6,2	3	6,8	A00080...	A00080...	A00080...
10	1,5	100	14	43	10	8	3	8,5	A00100...	A00100...	A00100...
12	1,75	110	18	-	9	7	3	10,2	A00120...	A00120...	A00120...
14	2	110	20,5	-	11	9	3	12	A00140...	A00140...	A00140...
16	2	110	19,5	-	12	9	3	14	A00160...	A00160...	A00160...
18	2,5	125	25	-	14	11	3	15,5	A00180...	A00180...	A00180...
20	2,5	140	27	-	16	12	3	17,5	A00200...	A00200...	A00200...
22	2,5	140	29	-	18	14,5	3	19,5	A00220...	A00220...	A00220...
24	3	160	34	-	18	14,5	3	21	A00240...	A00240...	A00240...



A170
VAP

A170
TiX2

A SERIES

DIN 371
≤ M10

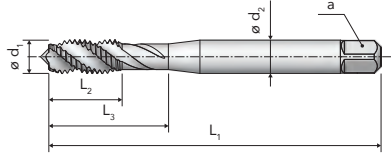

DIN 376
≥ M12

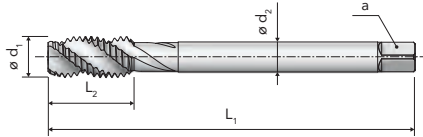

APPLICATION RANGE - CUTTING SPEED m/min

ISO	MG	A170 VAP	A170 TiX2
P	P.7	• 6-8	• 8-10
M	M.1	• 6-8	• 8-10



Ød ₁	P	L ₁ js 16	L ₂	L ₃	Ød ₂ h9	a h12	Z		A170 VAP ...1702A1AB0	A170 TiX2 ...1702A1AL0
[mm]	[mm]	[mm]	[mm]	[mm]	[mm]	[mm]	[-]	[mm]		
M 3	0,5	56	10	18	3,5	2,7	3	2,5	A00030...	A00030...
4	0,7	63	12	21	4,5	3,4	3	3,3	A00040...	A00040...
5	0,8	70	14	24,5	6	4,9	3	4,2	A00050...	A00050...
6	1	80	16	29	6	4,9	3	5	A00060...	A00060...
8	1,25	90	18	33	8	6,2	3	6,8	A00080...	A00080...
10	1,5	100	20	36	10	8	3	8,5	A00100...	A00100...
12	1,75	110	24	-	9	7	3	10,2	A00120...	A00120...
14	2	110	25	-	11	9	4	12	A00140...	A00140...
16	2	110	28	-	12	9	4	14	A00160...	A00160...
18	2,5	125	32	-	14	11	4	15,5	A00180...	A00180...
20	2,5	140	32	-	16	12	4	17,5	A00200...	A00200...



A62
BRIGHT

A62
TiH1

DIN 371
≤ M10

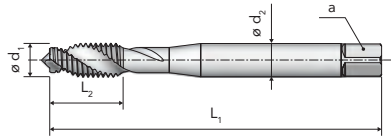

DIN 376
≥ M11

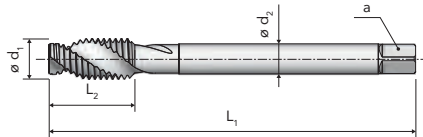

APPLICATION RANGE - CUTTING SPEED m/min

ISO	MG	A62 BRIGHT	A62 TiH1
N	N.1-2	• 12-15	• 25-30
	N.5-6	• 10-12	• 20-25
S	S.1	• 6-8	• 10-12
	S.3	• 6-8	• 10-12



$\varnothing d_1$	P	L_1 js16	L_2	L_3	$\varnothing d_2$ h9	a h12	Z		A62 BRIGHT ...0622A1AA0	A62 TiH1 ...0622A1AH0
[mm]	[mm]	[mm]	[mm]	[mm]	[mm]	[mm]	[-]	[mm]		
M2	0,4	45	7	11	2,8	2,1	2	1,6	A00020...	A00020...
2,2	0,45	45	8	13	2,8	2,1	2	1,75	A00022...	A00022...
2,3	0,4	45	8	13	2,8	2,1	2	1,9	A00023...	A00023...
2,5	0,45	50	9	15	2,8	2,1	2	2,05	A00025...	A00025...
2,6	0,45	50	9	15	2,8	2,1	2	2,1	A00026...	A00026...
3	0,5	56	10	18	3,5	2,7	2	2,5	A00030...	A00030...
3,5	0,6	56	11	20	4	3	2	2,9	A00035...	A00035...
4	0,7	63	12	21	4,5	3,4	2	3,3	A00040...	A00040...
5	0,8	70	14	24,5	6	4,9	2	4,2	A00050...	A00050...
6	1	80	16	29	6	4,9	2	5	A00060...	A00060...
7	1	80	16	29	7	5,5	2	6	A00070...	A00070...
8	1,25	90	18	33	8	6,2	2	6,8	A00080...	A00080...
9	1,25	90	18	33	9	7	2	7,8	A00090...	A00090...
10	1,5	100	20	36	10	8	2	8,5	A00100...	A00100...
11	1,5	100	20	-	8	6,2	2	9,5	A00110...	A00110...
12	1,75	110	24	-	9	7	2	10,2	A00120...	A00120...
14	2	110	25	-	11	9	2	12	A00140...	A00140...
16	2	110	28	-	12	9	3	14	A00160...	A00160...



A72
BRIGHT

A72
TiH1

A SERIES

DIN 371
≤ M10

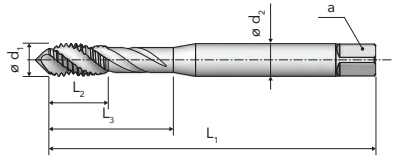

DIN 376
≥ M12

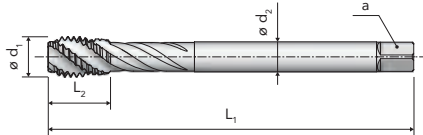

APPLICATION RANGE - CUTTING SPEED m/min

ISO	MG	A72 BRIGHT	A72 TiH1
P	P.1	• 12-15	• 25-30
N	N.1-2	• 12-15	• 25-30
	N.3	• 10-12	• 20-25
	N.5-6	• 10-12	• 20-25



Ød ₁	P	L ₁ js 16	L ₂	L ₃	Ød ₂ h9	a h12	Z	z	A72 BRIGHT ...0722A1AA0	A72 TiH1 ...0722A1AH0
[mm]	[mm]	[mm]	[mm]	[mm]	[mm]	[mm]	[-]	[mm]		
M 3	0,5	56	7	15	3,5	2,7	3	2,5	A00030...	A00030...
4	0,7	63	8,5	21	4,5	3,4	3	3,3	A00040...	A00040...
5	0,8	70	10	24,5	6	4,9	3	4,2	A00050...	A00050...
6	1	80	12	29	6	4,9	3	5	A00060...	A00060...
8	1,25	90	15	33	8	6,2	3	6,8	A00080...	A00080...
10	1,5	100	17,5	38	10	8	3	8,5	A00100...	A00100...
12	1,75	110	18	-	9	7	3	10,2	A00120...	A00120...
14	2	110	20,5	-	11	9	3	12	A00140...	A00140...
16	2	110	20,5	-	12	9	3	14	A00160...	A00160...
18	2,5	125	25,5	-	14	11	3	15,5	A00180...	A00180...
20	2,5	140	29,5	-	16	12	3	17,5	A00200...	A00200...



A9
BRIGHT

DIN 357

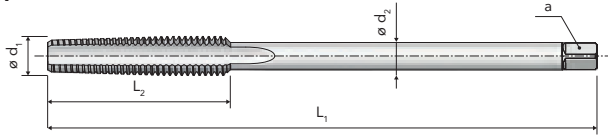

A
SERIES

APPLICATION RANGE - CUTTING SPEED m/min

ISO	MG	A9 BRIGHT			
		P.1	P.2	P.3	
P	P.1	• 18-20			
	P.2	• 15-18			
	P.3	• 12-15			



Ød ₁	P	L ₁ js16	L ₂	L ₃	Ød ₂ h9	a h12	Z	z	A9 BRIGHT ...0091A2AA0
[mm]	[mm]	[mm]	[mm]	[mm]	[mm]	[mm]	[-]	[mm]	
M 4	0,7	90	25	-	2,8	2,1	3	3,3	A00040...
5	0,8	100	28	-	3,5	2,7	3	4,2	A00050...
6	1	110	32	-	4,5	3,4	3	5	A00060...
8	1,25	125	40	-	6	4,9	3	6,8	A00080...
10	1,5	140	45	-	7	5,5	3	8,5	A00100...
12	1,75	180	50	-	9	7	3	10,2	A00120...
14	2	200	56	-	11	9	3	12	A00140...
16	2	200	63	-	12	9	3	14	A00160...
18	2,5	220	63	-	14	11	3	15,5	A00180...
20	2,5	250	70	-	16	12	3	17,5	A00200...
22	2,5	280	80	-	18	14,5	3	19,5	A00220...
24	3	280	80	-	18	14,5	3	21	A00240...
27	3	315	90	-	20	16	3	24	A00270...
30	3,5	315	100	-	22	18	3	26,5	A00300...



A80
TiN

A80 6GX
TiN

A SERIES

DIN 2174 (371)
≤ M10

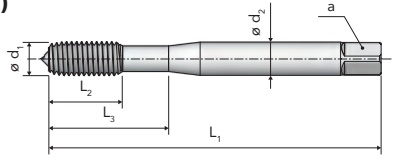

DIN 2174 (376)
≥ M12

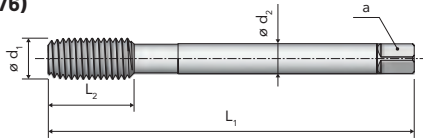

APPLICATION RANGE - CUTTING SPEED m/min

ISO	MG	A80 TiN	A80 6GX TiN
P	P.1-2	• 20-25	• 20-25
	P.3	• 15-20	• 15-20
N	N.1-2	• 20-25	• 20-25
	N.3	• 15-20	• 15-20
	N.5-6	• 20-25	• 20-25



Ød ₁	P	L ₁ js 16	L ₂	L ₃	Ød ₂ h9	a h12	Z		A80 TiN ...0802A1AD0	A80 6GX TiN ...0802A1CD0
[mm]	[mm]	[mm]	[mm]	[mm]	[mm]	[mm]	[-]	[mm]		
M 2	0,4	45	7	11	2,8	2,1	3	1,85	A00020...	A00020...
2,5	0,45	50	9	15	2,8	2,1	3	2,3	A00025...	A00025...
3	0,5	56	10	18	3,5	2,7	4	2,8	A00030...	A00030...
3,5	0,6	56	11	20	4	3	4	3,25	A00035...	A00035...
4	0,7	63	12	21	4,5	3,4	5	3,7	A00040...	A00040...
5	0,8	70	14	24,5	6	4,9	5	4,65	A00050...	A00050...
6	1	80	16	29	6	4,9	5	5,55	A00060...	A00060...
8	1,25	90	18	33	8	6,2	5	7,4	A00080...	A00080...
10	1,5	100	20	36	10	8	5	9,3	A00100...	A00100...
12	1,75	110	24	-	9	7	5	11,2	A00120...	A00120...
14	2	110	25	-	11	9	6	13,1	A00140...	A00140...
16	2	110	28	-	12	9	6	15,1	A00160...	A00160...



A80 N
TiN

A80 N 6GX
TiN

DIN 2174 (371)
≤ M10

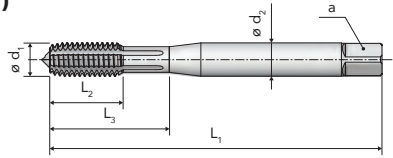

DIN 2174 (376)
≥ M12

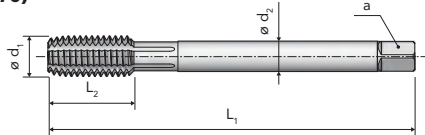

A SERIES

APPLICATION RANGE - CUTTING SPEED m/min

ISO	MG	A80 N TiN	A80 N 6GX TiN
P	P.1-2	• 20-25	• 20-25
	P.3	• 15-20	• 15-20
N	N.1-2	• 20-25	• 20-25
	N.3	• 15-20	• 15-20
	N.5-6	• 20-25	• 20-25



Ød ₁	P	L ₁ js16	L ₂	L ₃	Ød ₂ h9	a h12	Z		A80 N TiN ...0802G1ADO	A80 N 6GX TiN ...0802G1CDO
[mm]	[mm]	[mm]	[mm]	[mm]	[mm]	[mm]	[-]	[mm]		
M2	0,4	45	7	11	2,8	2,1	3	1,85	A00020...	A00020...
2,5	0,45	50	9	15	2,8	2,1	3	2,3	A00025...	A00025...
3	0,5	56	10	18	3,5	2,7	4	2,8	A00030...	A00030...
3,5	0,6	56	11	20	4	3	4	3,25	A00035...	A00035...
4	0,7	63	12	21	4,5	3,4	5	3,7	A00040...	A00040...
5	0,8	70	14	24,5	6	4,9	5	4,65	A00050...	A00050...
6	1	80	16	29	6	4,9	5	5,55	A00060...	A00060...
8	1,25	90	18	33	8	6,2	5	7,4	A00080...	A00080...
10	1,5	100	20	36	10	8	5	9,3	A00100...	A00100...
12	1,75	110	24	-	9	7	5	11,2	A00120...	A00120...
14	2	110	25	-	11	9	6	13,1	A00140...	A00140...
16	2	110	28	-	12	9	6	15,1	A00160...	A00160...
18	2,5	125	28	-	14	11	8	16,9	A00180...	
20	2,5	140	30	-	16	12	8	18,9	A00200...	



A190
BRIGHT

A SERIES

DIN 40435
≤ EG-M8

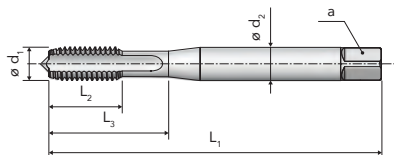

DIN 40435
≥ EG-M10

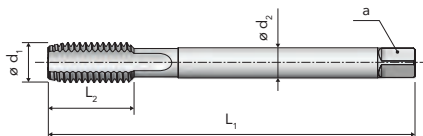

APPLICATION RANGE - CUTTING SPEED m/min

ISO	MG	A190 BRIGHT			
P	P.2	• 10-12			
	P.3	• 8-10			
K	K.2	• 8-10			



$\varnothing d_1$	P	L_1 js 16	L_2	L_3	$\varnothing d_2$ h9	a h12	Z		A190 BRIGHT ...1901A1AA0
[mm]	[mm]	[mm]	[mm]	[mm]	[mm]	[mm]	[-]	[mm]	
EG-M3	0,5	63	12	17	4,5	3,4	3	3,15	A00030...
4	0,7	70	14	24,5	6	4,9	3	4,2	A00040...
5	0,8	80	16	29	6	4,9	3	5,25	A00050...
6	1	90	18	33	8	6,2	3	6,3	A00060...
8	1,25	100	20	36	10	8	3	8,4	A00080...
10	1,5	100	22	-	9	7	3	10,5	A00100...
12	1,75	110	25	-	11	9	3	12,5	A00120...
14	2	110	28	-	12	9	3	14,5	A00140...
16	2	125	28	-	14	11	4	16,5	A00160...



A195
BRIGHT

A195
TiN

DIN 40435
≤ EG-M8

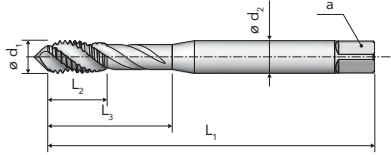

DIN 40435
≥ EG-M10

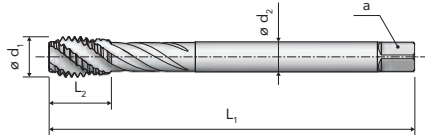

A
SERIES

APPLICATION RANGE - CUTTING SPEED m/min

ISO	MG	A195 BRIGHT	A195 TiN
P	P.2	• 15-20	• 25-30
	P.3	• 12-15	• 20-25
	P.4	• 10-12	• 15-20
	P.5		• 5-10
	P.7		• 6-8
M	M.1		• 6-8
K	K.2	• 12-15	• 20-25
N	N.3	• 15-18	• 25-30
	N.6	• 15-18	• 25-30



Ød ₁	P	L ₁ js 16	L ₂	L ₃	Ød ₂ h9	a h12	Z	z	A195 BRIGHT ...1952A1AA0	A195 TiN ...1952A1AD0
[mm]	[mm]	[mm]	[mm]	[mm]	[mm]	[mm]	[-]	[mm]		
EG-M3	0,5	63	8	18	4,5	3,4	3	3,15	A00030...	A00030...
4	0,7	70	10	24,5	6	4,9	3	4,2	A00040...	A00040...
5	0,8	80	12	29	6	4,9	3	5,25	A00050...	A00050...
6	1	90	14	33	8	6,2	3	6,3	A00060...	A00060...
8	1,25	100	16,5	38	10	8	3	8,4	A00080...	A00080...
10	1,5	100	17,5	-	9	7	3	10,5	A00100...	A00100...
12	1,75	110	19,5	-	11	9	3	12,5	A00120...	A00120...
16	2	125	22,5	-	14	11	4	16,5	A00160...	A00160...



A2
ROUGHING

A2
FINISHING

A2
SET

A SERIES

DIN 2181
≤ M6

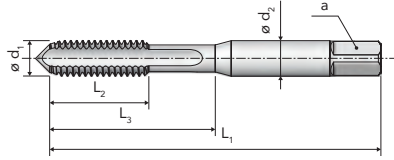

DIN 2181
≥ M7

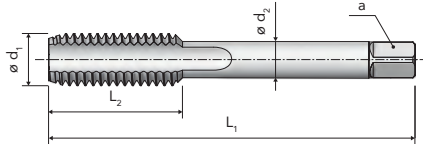

APPLICATION RANGE - CUTTING SPEED m/min

ISO	MG	A2 ROUGHING	A2 FINISHING	A2 SET
P	P.1-4	•	•	•
	P.7	•	•	•
K	K.2	•	•	•
N	N.1-3	•	•	•
	N.5-7	•	•	•

ISO 2 6H

ISO 2 6H

A (5-6)

C (2-3)

C (2-3)

2,5xD

2,5xD

2,5xD

RH

RH

RH

Ød ₁	P	L ₁ js 16	L ₂	L ₃	Ød ₂ h9	a h12	Z	Ø	A2 ROUGHING ...0021A1AA0	A2 FINISHING ...0021A3AA0	A2 SET ...0021ASAA0
[mm]	[mm]	[mm]	[mm]	[mm]	[mm]	[mm]	[-]	[mm]			
M 2	0,25	36	7,5	12	2,8	2,1	3	1,75	A02025...	A02025...	A02025...
2,3	0,25	36	8,5	13,5	2,8	2,1	3	2,05	A02325...	A02325...	A02325...
2,5	0,35	40	8,5	14,5	2,8	2,1	3	2,15	A02535...	A02535...	A02535...
2,6	0,35	40	8,5	14,5	2,8	2,1	3	2,25	A02635...	A02635...	A02635...
3	0,35	40	8	18	3,5	2,7	3	2,65	A03035...	A03035...	A03035...
3,5	0,35	45	9	19	4	3	3	3,15	A03535...	A03535...	A03535...
4	0,5	45	10	21	4,5	3,4	3	3,5	A04050...	A04050...	A04050...
4,5	0,5	50	12	23	6	4,9	3	4	A04550...	A04550...	A04550...
5	0,5	50	12	24	6	4,9	3	4,5	A05050...	A05050...	A05050...
6	0,5	56	14	28	6	4,9	3	5,5	A06050...	A06050...	A06050...
6	0,75	56	14	28	6	4,9	3	5,2	A06075...	A06075...	A06075...
7	0,75	56	14	-	6	4,9	3	6,2	A07075...	A07075...	A07075...
8	0,75	56	18	-	6	4,9	3	7,2	A08075...	A08075...	A08075...
8	1	63	22	-	6	4,9	3	7	A08100...	A08100...	A08100...
9	1	63	22	-	7	5,5	3	8	A09100...	A09100...	A09100...
10	0,75	63	20	-	7	5,5	4	9,2	A10075...	A10075...	A10075...
10	1	63	20	-	7	5,5	4	9	A10100...	A10100...	A10100...
10	1,25	70	24	-	7	5,5	3	8,8	A10125...	A10125...	A10125...
11	1	63	20	-	8	6,2	4	10	A11100...	A11100...	A11100...
12	0,75	70	22	-	9	7	4	11,2	A12075...	A12075...	A12075...
12	1	70	22	-	9	7	4	11	A12100...	A12100...	A12100...
12	1,25	70	22	-	9	7	4	10,8	A12125...	A12125...	A12125...
12	1,5	70	22	-	9	7	4	10,5	A12150...	A12150...	A12150...
14	1	70	22	-	11	9	4	13	A14100...	A14100...	A14100...
14	1,25	70	22	-	11	9	4	12,8	A14125...	A14125...	A14125...
14	1,5	70	22	-	11	9	4	12,5	A14150...	A14150...	A14150...



HAND TAPS for blind and through holes
In sets of two pieces



A2
ROUGHING

A2
FINISHING

A2
SET

DIN 2181

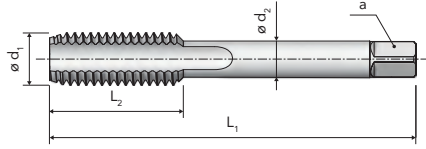

A SERIES

APPLICATION RANGE - CUTTING SPEED m/min

ISO	MG	A2 ROUGHING	A2 FINISHING	A2 SET
P	P.1-4	•	•	•
	P.7	•	•	•
K	K.2	•	•	•
N	N.1-3	•	•	•
	N.5-7	•	•	•

ISO2 6H

ISO2 6H

A (5-6)

C (2-3)

C (2-3)

2,5xD

2,5xD

2,5xD

RH

RH

RH

$\varnothing d_1$	P	L_1 js16	L_2	L_3	$\varnothing d_2$ h9	a h12	z		A2 ROUGHING ...0021A1AA0	A2 FINISHING ...0021A3AA0	A2 SET ...0021ASAA0
[mm]	[mm]	[mm]	[mm]	[mm]	[mm]	[mm]	[-]	[mm]			
M 15	1	70	22	-	12	9	4	14	A15100...	A15100...	A15100...
15	1,5	70	22	-	12	9	4	13,5	A15150...	A15150...	A15150...
16	1	70	22	-	12	9	4	15	A16100...	A16100...	A16100...
16	1,25	70	22	-	12	9	4	14,8	A16125...	A16125...	A16125...
16	1,5	70	22	-	12	9	4	14,5	A16150...	A16150...	A16150...
18	1	80	22	-	14	11	4	17	A18100...	A18100...	A18100...
18	1,5	80	22	-	14	11	4	16,5	A18150...	A18150...	A18150...
18	2	80	22	-	14	11	4	16	A18200...	A18200...	A18200...
20	1	80	22	-	16	12	4	19	A20100...	A20100...	A20100...
20	1,5	80	22	-	16	12	4	18,5	A20150...	A20150...	A20150...
20	2	80	22	-	16	12	4	18	A20200...	A20200...	A20200...
22	1	80	22	-	18	14,5	4	21	A22100...	A22100...	A22100...
22	1,5	80	22	-	18	14,5	4	20,5	A22150...	A22150...	A22150...
22	2	80	22	-	18	14,5	4	20	A22200...	A22200...	A22200...
24	1	90	22	-	18	14,5	4	23	A24100...	A24100...	A24100...
24	1,5	90	22	-	18	14,5	4	22,5	A24150...	A24150...	A24150...
24	2	90	22	-	18	14,5	4	22	A24200...	A24200...	A24200...
25	1,5	90	22	-	18	14,5	4	23,5	A25150...	A25150...	A25150...
25	2	90	22	-	18	14,5	4	23	A25200...	A25200...	A25200...
26	1,5	90	22	-	18	14,5	4	24,5	A26150...	A26150...	A26150...
26	2	90	22	-	18	14,5	4	24	A26200...	A26200...	A26200...
27	1,5	90	22	-	20	16	4	25,5	A27150...	A27150...	A27150...
27	2	90	22	-	20	16	4	25	A27200...	A27200...	A27200...
28	1,5	90	22	-	20	16	4	26,5	A28150...	A28150...	A28150...
28	2	90	22	-	20	16	4	26	A28200...	A28200...	A28200...
30	1,5	90	22	-	22	18	4	28,5	A30150...	A30150...	A30150...



A2
ROUGHING

A2
FINISHING

A2
SET

DIN 2181

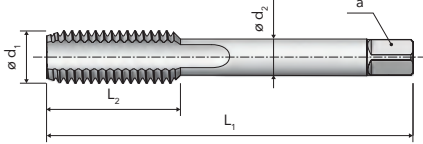

APPLICATION RANGE - CUTTING SPEED m/min

ISO	MG	A2 ROUGHING	A2 FINISHING	A2 SET
P	P.1-4	•	•	•
	P.7	•	•	•
K	K.2	•	•	•
N	N.1-3	•	•	•
	N.5-7	•	•	•



<<

$\varnothing d_1$	P	L_1 js 16	L_2	L_3	$\varnothing d_2$ h9	a h12	Z		A2 ROUGHING ...0021A1AA0	A2 FINISHING ...0021A3AA0	A2 SET ...0021ASAA0
[mm]	[mm]	[mm]	[mm]	[mm]	[mm]	[mm]	[-]	[mm]			
M 30	2	90	22	-	22	18	4	28	A30200...	A30200...	A30200...
32	1,5	90	22	-	22	18	5	30,5	A32150...	A32150...	A32150...
32	2	90	22	-	22	18	4	30	A32200...	A32200...	A32200...
33	2	100	25	-	25	20	4	31	A33200...	A33200...	A33200...
35	1,5	100	25	-	28	22	5	33,5	A35150...	A35150...	A35150...
35	2	125	30	-	28	22	5	33	A35200...	A35200...	A35200...
36	1,5	100	25	-	28	22	5	34,5	A36150...	A36150...	A36150...
36	2	125	30	-	28	22	5	34	A36200...	A36200...	A36200...
36	3	125	40	-	28	22	4	33	A36300...	A36300...	A36300...
38	1,5	100	25	-	28	22	5	36,5	A38150...	A38150...	A38150...
39	2	125	32	-	32	24	5	37	A39200...	A39200...	A39200...
39	3	125	40	-	32	24	4	36	A39300...	A39300...	A39300...
40	1,5	110	25	-	32	24	6	38,5	A40150...	A40150...	A40150...
40	2	125	32	-	32	24	5	38	A40200...	A40200...	A40200...
40	3	125	40	-	32	24	4	37	A40300...	A40300...	A40300...
42	1,5	110	25	-	32	24	6	40,5	A42150...	A42150...	A42150...
42	2	125	32	-	32	24	5	40	A42200...	A42200...	A42200...
42	3	125	40	-	32	24	4	39	A42300...	A42300...	A42300...
45	1,5	110	25	-	36	29	6	43,5	A45150...	A45150...	A45150...
45	2	125	32	-	36	29	5	43	A45200...	A45200...	A45200...
45	3	125	40	-	36	29	5	42	A45300...	A45300...	A45300...
48	1,5	140	25	-	36	29	6	46,5	A48150...	A48150...	A48150...
48	2	140	32	-	36	29	6	46	A48200...	A48200...	A48200...
48	3	140	40	-	36	29	5	45	A48300...	A48300...	A48300...

HAND TAPS for blind and through holes
In sets of two pieces



A2 LH
ROUGHING

A2 LH
FINISHING

A2 LH
SET

DIN 2181
≤ M6

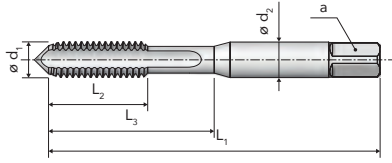

DIN 2181
≥ M8

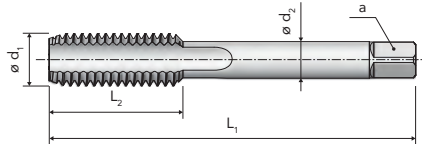

A
SERIES

APPLICATION RANGE - CUTTING SPEED m/min

ISO	MG	A2 LH ROUGHING	A2 LH FINISHING	A2 LH SET
P	P.1-4	•	•	•
	P.7	•	•	•
K	K.2	•	•	•
N	N.1-3	•	•	•
	N.5-7	•	•	•

—

ISO2 6H

ISO2 6H

A (5-6)

C (2-3)

C (2-3)

2,5xD

2,5xD

2,5xD

LH

LH

LH

Ød ₁	P	L ₁ js16	L ₂	L ₃	Ød ₂ h9	a h12	Z		A2 LH ROUGHING ...0021C1AA0	A2 LH FINISHING ...0021C3AA0	A2 LH SET ...0021CSAA0
[mm]	[mm]	[mm]	[mm]	[mm]	[mm]	[mm]	[-]	[mm]			
M 4	0,5	45	10	21	4,5	3,4	3	3,5	A04050...	A04050...	A04050...
5	0,5	50	12	24	6	4,9	3	4,5	A05050...	A05050...	A05050...
6	0,75	56	14	28	6	4,9	3	5,2	A06075...	A06075...	A06075...
8	1	63	22	-	6	4,9	3	7	A08100...	A08100...	A08100...
10	1	63	20	-	7	5,5	4	9	A10100...	A10100...	A10100...
10	1,25	70	24	-	7	5,5	3	8,8	A10125...	A10125...	A10125...
11	1	63	20	-	8	6,2	4	10	A11100...	A11100...	A11100...
12	1	70	22	-	9	7	4	11	A12100...	A12100...	A12100...
12	1,25	70	22	-	9	7	4	10,8	A12125...	A12125...	A12125...
12	1,5	70	22	-	9	7	4	10,5	A12150...	A12150...	A12150...
14	1,5	70	22	-	11	9	4	12,5	A14150...	A14150...	A14150...
16	1,5	70	22	-	12	9	4	14,5	A16150...	A16150...	A16150...
18	1,5	80	22	-	14	11	4	16,5	A18150...	A18150...	A18150...
20	1,5	80	22	-	16	12	4	18,5	A20150...	A20150...	A20150...



A23 FC
BRIGHT

A23 FC
TiN

A23 FC LH
BRIGHT

A SERIES

DIN 374

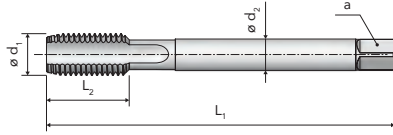

APPLICATION RANGE - CUTTING SPEED m/min

ISO	MG	A23 FC BRIGHT	A23 FC TiN	A23 FC LH BRIGHT
P	P.1		• 20-25	
	P.2	• 10-12	• 15-20	• 10-12
	P.3	• 8-10	• 12-15	• 8-10
K	K.2	• 8-10	• 12-15	• 8-10
N	N.1		• 20-25	
	N.5		• 15-20	



$\varnothing d_1$	P	L_1 js 16	L_2	L_3	$\varnothing d_2$ h9	a h12	z		A23 FC BRIGHT ...0232A1AA0	A23 FC TiN ...0232A1AD0	A23 FC LH BRIGHT ...0232C1AA0
[mm]	[mm]	[mm]	[mm]	[mm]	[mm]	[mm]	[-]	[mm]			
M3	0,35	56	8	-	2,2	-	3	2,65	A03035...		
3,5	0,35	56	9	-	2,5	2,1	3	3,15	A03535...		
4	0,5	63	12	-	2,8	2,1	3	3,5	A04050...		
5	0,5	70	14	-	3,5	2,7	3	4,5	A05050...		
6	0,5	80	16	-	4,5	3,4	3	5,5	A06050...	A06050...	
6	0,75	80	16	-	4,5	3,4	3	5,2	A06075...	A06075...	A06075...
7	0,75	80	16	-	5,5	4,3	3	6,2	A07075...	A07075...	
8	0,75	80	16	-	6	4,9	3	7,2	A08075...		
8	1	90	16	-	6	4,9	3	7	A08100...	A08100...	A08100...
9	1	90	16	-	7	5,5	3	8	A09100...		
10	0,5	90	18	-	7	5,5	4	9,5	A10050...	A10050..	
10	0,75	90	18	-	7	5,5	3	9,2	A10075...		
10	1	90	18	-	7	5,5	3	9	A10100...	A10100...	A10100...
10	1,25	100	18	-	7	5,5	3	8,8	A10125...	A10125...	A10125...
11	1	90	20	-	8	6,2	3	10	A11100...		
12	0,75	100	22	-	9	7	4	11,2	A12075...	A12075...	
12	1	100	22	-	9	7	4	11	A12100...	A12100...	
12	1,25	100	22	-	9	7	3	10,8	A12125...	A12125...	A12125...
12	1,5	100	22	-	9	7	3	10,5	A12150...	A12150...	A12150...
14	1	100	22	-	11	9	4	13	A14100...	A14100...	
14	1,25	100	22	-	11	9	3	12,8	A14125...	A14125...	
14	1,5	100	22	-	11	9	3	12,5	A14150...	A14150...	A14150...
15	1	100	22	-	12	9	4	14	A15100...		
15	1,5	100	22	-	12	9	3	13,5	A15150...		
16	1	100	22	-	12	9	4	15	A16100...	A16100...	
16	1,25	100	22	-	12	9	4	14,8	A16125...	A16125...	





A23 FC
BRIGHT

A23 FC
TiN

A23 FC LH
BRIGHT

DIN 374

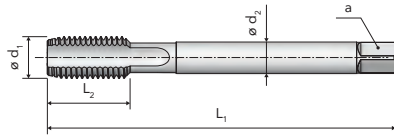

A
SERIES

APPLICATION RANGE - CUTTING SPEED m/min

ISO	MG	A23 FC BRIGHT	A23 FC TiN	A23 FC LH BRIGHT
P	P.1		● 20-25	
	P.2	● 10-12	● 15-20	● 10-12
	P.3	● 8-10	● 12-15	● 8-10
K	K.2	● 8-10	● 12-15	● 8-10
N	N.1		● 20-25	
	N.5		● 15-20	



$\varnothing d_1$	P	L_1 js16	L_2	L_3	$\varnothing d_2$ h9	a h12	Z		A23 FC BRIGHT ...0232A1AA0	A23 FC TiN ...0232A1AD0	A23 FC LH BRIGHT ...0232C1AA0
[mm]	[mm]	[mm]	[mm]	[mm]	[mm]	[mm]	[-]	[mm]			
M 16	1,5	100	22	-	12	9	3	14,5	A16150...	A16150...	A16150...
17	1	100	22	-	12	9	4	16	A17100...		
17	1,5	100	22	-	12	9	4	15,5	A17150...		
18	1	110	25	-	14	11	4	17	A18100...		
18	1,5	110	25	-	14	11	4	16,5	A18150...	A18150...	A18150...
18	2	125	28	-	14	11	4	16	A18200...		
20	1	125	25	-	16	12	4	19	A20100...		
20	1,5	125	25	-	16	12	4	18,5	A20150...	A20150...	A20150...
20	2	140	28	-	16	12	4	18	A20200...		
22	1	125	25	-	18	14,5	4	21	A22100...		
22	1,5	125	25	-	18	14,5	4	20,5	A22150...	A22150...	
22	2	140	28	-	18	14,5	4	20	A22200...		
24	1	140	25	-	18	14,5	4	23	A24100...		
24	1,5	140	25	-	18	14,5	4	22,5	A24150...		
24	2	140	28	-	18	14,5	4	22	A24200...		
25	1	140	25	-	18	14,5	4	24	A25100...		
25	1,5	140	25	-	18	14,5	4	23,5	A25150...		
25	2	140	28	-	18	14,5	4	23	A25200...		
26	1	140	25	-	18	14,5	4	25	A26100...		
26	1,5	140	25	-	18	14,5	4	24,5	A26150...		
26	2	140	28	-	18	14,5	4	24	A26200...		
27	1,5	140	28	-	20	16	4	25,5	A27150...		
27	2	140	28	-	20	16	4	25	A27200...		
28	1,5	140	28	-	20	16	4	26,5	A28150...		
28	2	140	28	-	20	16	4	26	A28200...		
30	1	150	25	-	22	18	5	29	A30100...		



A23 FC
BRIGHT

A SERIES

DIN 374

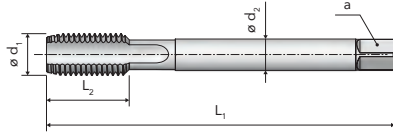

APPLICATION RANGE - CUTTING SPEED m/min

ISO	MG	A23 FC BRIGHT			
P	P.2	• 10-12			
	P.3	• 8-10			
K	K.2	• 8-10			



«	Ød ₁	P	L ₁ js 16	L ₂	L ₃	Ød ₂ h9	a h12	Z		A23 FC BRIGHT ...0232A1AA0
	[mm]	[mm]	[mm]	[mm]	[mm]	[mm]	[mm]	[-]	[mm]	
M 30	1,5	150	28	-	22	18	4	28,5	A30150...	
30	2	150	28	-	22	18	4	28	A30200...	
32	1,5	150	28	-	22	18	5	30,5	A32150...	
32	2	150	28	-	22	18	4	30	A32200...	
33	1,5	160	30	-	25	20	5	31,5	A33150...	
33	2	160	30	-	25	20	4	31	A33200...	
35	1,5	170	30	-	28	22	5	33,5	A35150...	
35	2	170	30	-	28	22	5	33	A35200...	
36	1,5	170	30	-	28	22	5	34,5	A36150...	
36	2	170	30	-	28	22	5	34	A36200...	
36	3	200	55	-	28	22	4	33	A36300...	
39	3	200	60	-	32	24	5	36	A39300...	
40	1,5	170	30	-	32	24	5	38,5	A40150...	
40	2	170	30	-	32	24	5	38	A40200...	
40	3	200	60	-	32	24	5	37	A40300...	
42	1,5	170	30	-	32	24	6	40,5	A42150...	
42	2	170	30	-	32	24	5	40	A42200...	
42	3	200	60	-	32	24	5	39	A42300...	
45	1,5	180	32	-	36	29	6	43,5	A45150...	
45	2	180	32	-	36	29	5	43	A45200...	
45	3	200	50	-	36	29	5	42	A45300...	
48	1,5	190	32	-	36	29	6	46,5	A48150...	
48	2	190	32	-	36	29	6	46	A48200...	
48	3	225	50	-	36	29	5	45	A48300...	
52	1,5	190	32	-	40	32	6	50,5	A52150...	
52	2	190	32	-	40	32	6	50	A52200...	
52	3	225	50	-	40	32	5	49	A52300...	



HSSE

A45
NITRIDED

A45
TiCN

DIN 374

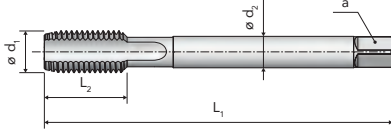

A
SERIES

APPLICATION RANGE - CUTTING SPEED m/min

ISO	MG	A45 NITRIDED	A45 TiCN
K	K.1	• 15-20	• 40-45
N	N.4	• 15-20	• 40-45
	N.7	• 15-20	• 40-45
	N.9-10	• 20-25	• 45-50

6HX

6HX



Ød ₁	P	L ₁ js16	L ₂	L ₃	Ød ₂ h9	a h12	Z		A45 NITRIDED ...0452A1ACO	A45 TiCN ...0452A1AEO
[mm]	[mm]	[mm]	[mm]	[mm]	[mm]	[mm]	[-]	[mm]		
M 4	0,5	63	10	-	2,8	2,1	3	3,5	A04050...	A04050...
5	0,5	70	12	-	3,5	2,7	3	4,5	A05050...	A05050...
6	0,75	80	14	-	4,5	3,4	3	5,2	A06075...	A06075...
8	1	90	16	-	6	4,9	4	7	A08100...	A08100...
9	1	90	16	-	7	5,5	4	8	A09100...	
10	1	90	18	-	7	5,5	4	9	A10100...	A10100...
10	1,25	100	18	-	7	5,5	4	8,8	A10125...	A10125...
11	1	90	20	-	8	6,2	4	10	A11100...	
12	1	100	22	-	9	7	4	11	A12100...	
12	1,25	100	22	-	9	7	4	10,8	A12125...	A12125...
12	1,5	100	22	-	9	7	4	10,5	A12150...	A12150...
14	1	100	22	-	11	9	4	13	A14100...	
14	1,25	100	22	-	11	9	4	12,8	A14125...	A14125...
14	1,5	100	22	-	11	9	4	12,5	A14150...	A14150...
16	1	100	22	-	12	9	4	15	A16100...	
16	1,5	100	22	-	12	9	4	14,5	A16150...	A16150...
18	1,5	110	25	-	14	11	4	16,5	A18150...	A18150...
20	1,5	125	25	-	16	12	4	18,5	A20150...	A20150...
22	1,5	125	25	-	18	14,5	4	20,5	A22150...	
24	1,5	140	25	-	18	14,5	5	22,5	A24150...	
24	2	140	28	-	18	14,5	5	22	A24200...	
27	1,5	140	28	-	20	16	5	25,5	A27150...	
27	2	140	28	-	20	16	5	25	A27200...	
30	1,5	150	28	-	22	18	5	28,5	A30150...	
30	2	150	28	-	22	18	5	28	A30200...	





A17 S
BRIGHT

A17 S
VAP

A17 S
TiN

A17 S
TiCN

A SERIES

DIN 374

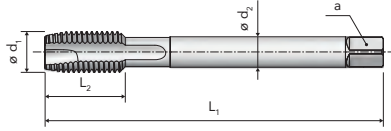

APPLICATION RANGE - CUTTING SPEED m/min

ISO	MG	A17 S BRIGHT	A17 S VAP	A17 S TiN	A17 S TiCN
P	P.2	● 20-25	● 20-25	● 30-35	● 30-35
	P.3	● 15-20	● 15-20	● 25-30	● 25-30
	P.4	● 12-15	● 12-15	● 20-25	● 20-25
	P.5			● 10-15	● 10-15
	P.7			● 8-10	● 8-10
M	M.1			● 8-10	● 8-10
K	K.2	● 15-20	● 15-20	● 25-30	● 25-30
N	N.2-3	● 20-25	● 20-25	● 30-35	● 30-35
	N.6	● 15-18	● 15-18	● 25-30	● 25-30



Ød ₁	P	L ₁ js 16	L ₂	L ₃	Ød ₂ h9	a h12	z		A17 S BRIGHT ...0172B2AA0	A17 S VAP ...0172B2AB0	A17 S TiN ...0172B2AD0	A17 S TiCN ...0172B2AE0
[mm]	[mm]	[mm]	[mm]	[mm]	[mm]	[mm]	[-]	[mm]				
M 3	0,35	56	8	-	2,2	-	3	2,65	A03035...		A03035...	
4	0,5	63	12	-	2,8	2,1	3	3,5	A04050...			
5	0,5	70	14	-	3,5	2,7	3	4,5	A05050...			
6	0,5	80	16	-	4,5	3,4	3	5,5	A06050...		A06050...	
6	0,75	80	16	-	4,5	3,4	3	5,2	A06075...	A06075...	A06075...	A06075...
7	0,75	80	16	-	5,5	4,3	3	6,2	A07075...			
8	0,75	80	16	-	6	4,9	3	7,2	A08075...			
8	1	90	16	-	6	4,9	3	7	A08100...	A08100...	A08100...	A08100...
9	1	90	16	-	7	5,5	3	8	A09100...			
10	0,75	90	18	-	7	5,5	4	9,2	A10075...			
10	1	90	18	-	7	5,5	4	9	A10100...	A10100...	A10100...	A10100...
10	1,25	100	18	-	7	5,5	3	8,8	A10125...	A10125...	A10125...	A10125...
11	1	90	20	-	8	6,2	4	10	A11100...			
12	1	100	22	-	9	7	4	11	A12100...	A12100...	A12100...	A12100...
12	1,25	100	22	-	9	7	4	10,8	A12125...	A12125...	A12125...	A12125...
12	1,5	100	22	-	9	7	3	10,5	A12150...	A12150...	A12150...	A12150...
14	1	100	22	-	11	9	4	13	A14100...			
14	1,25	100	22	-	11	9	4	12,8	A14125...	A14125...	A14125...	A14125...
14	1,5	100	22	-	11	9	4	12,5	A14150...	A14150...	A14150...	A14150...
15	1	100	22	-	12	9	4	14	A15100...			
15	1,5	100	22	-	12	9	4	13,5	A15150...			
16	1	100	22	-	12	9	4	15	A16100...			
16	1,5	100	22	-	12	9	4	14,5	A16150...	A16150...	A16150...	A16150...
18	1	110	25	-	14	11	4	17	A18100...			
18	1,5	110	25	-	14	11	4	16,5	A18150...	A18150...	A18150...	A18150...
20	1	125	25	-	16	12	4	19	A20100...			



MACHINE TAPS for through holes
Straight flutes with spiral point



A17 S
BRIGHT

A17 S
VAP

A17 S
TiN

A17 S
TiCN

DIN 374

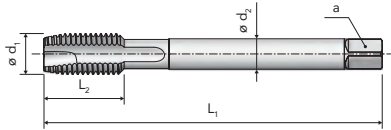

A SERIES

APPLICATION RANGE - CUTTING SPEED m/min

ISO	MG	A17 S BRIGHT	A17 S TiN
P	P.2	• 20-25	• 30-35
	P.3	• 15-20	• 25-30
	P.4	• 12-15	• 20-25
	P.5		• 10-15
	P.7		• 8-10
M	M.1		• 8-10
K	K.2	• 15-20	• 25-30
N	N.2-3	• 20-25	• 30-35
	N.6	• 15-18	• 25-30



<<

$\varnothing d_1$	P	L_1 js16	L_2	L_3	$\varnothing d_2$ h9	a h12	z		A17 S BRIGHT ...0172B2AA0	A17 S VAP ...0172B2AB0	A17 S TiN ...0172B2AD0	A17 S TiCN ...0172B2AE0
[mm]	[mm]	[mm]	[mm]	[mm]	[mm]	[mm]	[-]	[mm]				
M20	1,5	125	25	-	16	12	4	18,5	A20150...		A20150...	
22	1	125	25	-	18	14,5	4	21	A22100...			
22	1,5	125	25	-	18	14,5	4	20,5	A22150...		A22150...	
24	1	140	25	-	18	14,5	5	23	A24100...			
24	1,5	140	25	-	18	14,5	4	22,5	A24150...		A24150...	
24	2	140	28	-	18	14,5	4	22	A24200...			
25	1,5	140	25	-	18	14,5	4	23,5	A25150...			
25	2	140	28	-	18	14,5	4	23	A25200...			
26	1,5	140	25	-	18	14,5	4	24,5	A26150...			
26	2	140	28	-	18	14,5	4	24	A26200...			
27	1,5	140	28	-	20	16	4	25,5	A27150...		A27150...	
27	2	140	28	-	20	16	4	25	A27200...			
28	1,5	140	28	-	20	16	4	26,5	A28150...			
28	2	140	28	-	20	16	4	26	A28200...			
30	1,5	150	28	-	22	18	4	28,5	A30150...		A30150...	
30	2	150	28	-	22	18	4	28	A30200...			
32	1,5	150	28	-	22	18	5	30,5	A32150...			
32	2	150	28	-	22	18	4	30	A32200...			
36	1,5	170	30	-	28	22	5	34,5	A36150...			
36	2	170	30	-	28	22	5	34	A36200...			
36	3	200	55	-	28	22	4	33	A36300...			
40	1,5	170	30	-	32	24	5	38,5	A40150...			
40	2	170	30	-	32	24	5	38	A40200...			
40	3	200	60	-	32	24	4	37	A40300...			
42	1,5	170	30	-	32	24	5	40,5	A42150...			
42	2	170	30	-	32	24	5	40	A42200...			

>>



A17 S
BRIGHT

A SERIES

DIN 374

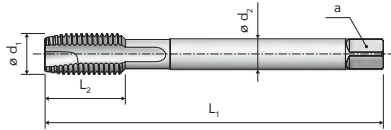

APPLICATION RANGE - CUTTING SPEED m/min

ISO	MG	A17 S BRIGHT			
P	P.2	● 20-25			
	P.3	● 15-20			
	P.4	● 12-15			
K	K.2	● 15-20			
N	N.2-3	● 20-25			
	N.6	● 15-18			



<<

Ød ₁	P	L ₁ js 16	L ₂	L ₃	Ød ₂ h9	a h12	Z		A17 S BRIGHT ...0172B2AA0
[mm]	[mm]	[mm]	[mm]	[mm]	[mm]	[mm]	[-]	[mm]	
M 42	3	200	60	-	32	24	5	39	A42300...
45	1,5	180	32	-	36	29	6	43,5	A45150...
45	2	180	32	-	36	29	5	43	A45200...
45	3	200	50	-	36	29	5	42	A45300...
48	1,5	190	32	-	36	29	6	46,5	A48150...
48	2	190	32	-	36	29	5	46	A48200...
48	3	225	50	-	36	29	5	45	A48300...



A17 S
TiX2

DIN 374

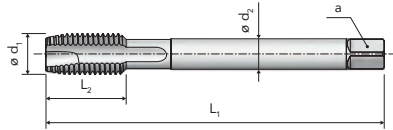

A SERIES

APPLICATION RANGE - CUTTING SPEED m/min

ISO	MG	A17 S TiX2			
P	P.7	• 10-12			
M	M.1	• 10-12			



Ød ₁	P	L ₁ js 16	L ₂	L ₃	Ød ₂ h9	a h12	Z	z	A17 S TiX2 ...0172B2ALO
[mm]	[mm]	[mm]	[mm]	[mm]	[mm]	[mm]	[-]	[mm]	
M 6	0,75	80	16	-	4,5	3,4	3	5,2	A06075...
8	1	90	16	-	6	4,9	3	7	A08100...
10	1	90	18	-	7	5,5	4	9	A10100...
10	1,25	100	18	-	7	5,5	3	8,8	A10125...
12	1,25	100	22	-	9	7	4	10,8	A12125...
12	1,5	100	22	-	9	7	3	10,5	A12150...
14	1,25	100	22	-	11	9	4	12,8	A14125...
14	1,5	100	22	-	11	9	4	12,5	A14150...
16	1,5	100	22	-	12	9	4	14,5	A16150...
20	1,5	125	25	-	16	12	4	18,5	A20150...



A30
BRIGHT

A30
TiN

DIN 374

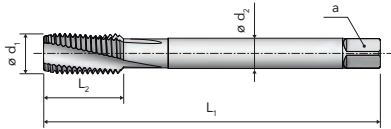

A SERIES

APPLICATION RANGE - CUTTING SPEED m/min

ISO	MG	A30 BRIGHT	A30 TiN
P	P.1	• 18-20	• 30-35
	P.2	• 15-18	• 25-30
	P.3	• 12-15	• 20-25
	P.4	• 10-12	• 15-20
	P.5		• 5-10
K	K.2	• 12-15	• 20-25
N	N.1	• 18-20	
	N.2-3	• 15-18	• 25-30
	N.5	• 15-18	
	N.6	• 12-15	• 20-25



Ød ₁	P	L ₁ js16	L ₂	L ₃	Ød ₂ h9	a h12	Z		A30 BRIGHT ...0302A1AA0	A30 TiN ...0302A1AD0
[mm]	[mm]	[mm]	[mm]	[mm]	[mm]	[mm]	[-]	[mm]		
M 3	0,35	56	8	-	2,2	-	3	2,65	A03035...	A03035...
3,5	0,35	56	9	-	2,5	2,1	3	3,15	A03535...	
4	0,5	63	12	-	2,8	2,1	3	3,5	A04050...	A04050...
5	0,5	70	14	-	3,5	2,7	3	4,5	A05050...	A05050...
6	0,75	80	16	-	4,5	3,4	3	5,2	A06075...	A06075...
7	0,75	80	16	-	5,5	4,3	3	6,2	A07075...	
8	0,75	80	16	-	6	4,9	3	7,2	A08075...	A08075...
8	1	90	16	-	6	4,9	3	7	A08100...	A08100...
9	1	90	16	-	7	5,5	3	8	A09100...	
10	0,75	90	18	-	7	5,5	3	9,2	A10075...	
10	1	90	18	-	7	5,5	3	9	A10100...	A10100...
10	1,25	100	18	-	7	5,5	3	8,8	A10125...	A10125...
11	1	90	20	-	8	6,2	3	10	A11100...	
12	1	100	22	-	9	7	3	11	A12100...	A12100...
12	1,25	100	22	-	9	7	3	10,8	A12125...	A12125...
12	1,5	100	22	-	9	7	3	10,5	A12150...	A12150...
14	1	100	22	-	11	9	3	13	A14100...	A14100...
14	1,25	100	22	-	11	9	3	12,8	A14125...	A14125...
14	1,5	100	22	-	11	9	3	12,5	A14150...	A14150...
15	1	100	22	-	12	9	4	14	A15100...	A15100...
15	1,5	100	22	-	12	9	3	13,5	A15150...	
16	1	100	22	-	12	9	4	15	A16100...	A16100...
16	1,25	100	22	-	12	9	4	14,8	A16125...	
16	1,5	100	22	-	12	9	4	14,5	A16150...	A16150...
17	1	100	22	-	12	9	4	16	A17100...	
17	1,5	100	22	-	12	9	4	15,5	A17150...	





A30
BRIGHT

A30
TiN

A SERIES

DIN 374

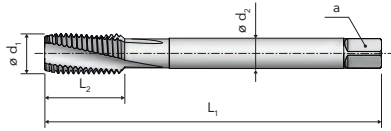

APPLICATION RANGE - CUTTING SPEED m/min

ISO	MG	A30 BRIGHT	A30 TiN
P	P.1	• 18-20	• 30-35
	P.2	• 15-18	• 25-30
	P.3	• 12-15	• 20-25
	P.4	• 10-12	• 15-20
	P.5		• 5-10
K	K.2	• 12-15	• 20-25
N	N.1	• 18-20	
	N.2-3	• 15-18	• 25-30
	N.5	• 15-18	
	N.6	• 12-15	• 20-25



Ød ₁	P	L ₁ js 16	L ₂	L ₃	Ød ₂ h9	a h12	z		A30 BRIGHT ...0302A1AA0	A30 TiN ...0302A1A00
[mm]	[mm]	[mm]	[mm]	[mm]	[mm]	[mm]	[-]	[mm]		
M 18	1	110	25	-	14	11	4	17	A18100...	A18100...
18	1,5	110	25	-	14	11	4	16,5	A18150...	A18150...
20	1	125	25	-	16	12	4	19	A20100...	A20100...
20	1,5	125	25	-	16	12	4	18,5	A20150...	A20150...
22	1	125	25	-	18	14,5	4	21	A22100...	
22	1,5	125	25	-	18	14,5	4	20,5	A22150...	A22150...
24	1	140	25	-	18	14,5	4	23	A24100...	
24	1,5	140	25	-	18	14,5	4	22,5	A24150...	A24150...
24	2	140	28	-	18	14,5	4	22	A24200...	
25	1	140	25	-	18	14,5	4	24	A25100...	
25	1,5	140	25	-	18	14,5	4	23,5	A25150...	
25	2	140	28	-	18	14,5	4	23	A25200...	
26	1	140	25	-	18	14,5	4	25	A26100...	
26	1,5	140	25	-	18	14,5	4	24,5	A26150...	
26	2	140	28	-	18	14,5	4	24	A26200...	
27	1,5	140	28	-	20	16	4	25,5	A27150...	A27150...
27	2	140	28	-	20	16	4	25	A27200...	
28	1,5	140	28	-	20	16	4	26,5	A28150...	
28	2	140	28	-	20	16	4	26	A28200...	
30	1	150	25	-	22	18	5	29	A30100...	
30	1,5	150	28	-	22	18	4	28,5	A30150...	A30150...
30	2	150	28	-	22	18	4	28	A30200...	
32	1,5	150	28	-	22	18	5	30,5	A32150...	
32	2	150	28	-	22	18	4	30	A32200...	
36	1,5	170	30	-	28	22	5	34,5	A36150...	
36	2	170	30	-	28	22	5	34	A36200...	



A30
BRIGHT

DIN 374

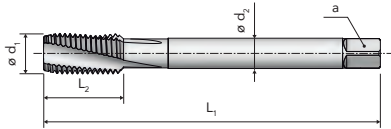

A SERIES

APPLICATION RANGE - CUTTING SPEED m/min

ISO	MG	A30 BRIGHT			
P	P.1	• 18-20			
	P.2	• 15-18			
	P.3	• 12-15			
	P.4	• 10-12			
K	K.2	• 12-15			
N	N.1	• 18-20			
	N.2-3	• 15-18			
	N.5	• 15-18			
	N.6	• 12-15			



<<

$\varnothing d_1$	P	L_1 js16	L_2	L_3	$\varnothing d_2$ h9	a h12	Z		A30 BRIGHT ...0302A1AA0
[mm]	[mm]	[mm]	[mm]	[mm]	[mm]	[mm]	[-]	[mm]	
M 36	3	200	55	-	28	22	4	33	A36300...
40	1,5	170	30	-	32	24	5	38,5	A40150...
40	2	170	30	-	32	24	5	38	A40200...
40	3	200	60	-	32	24	5	37	A40300...
42	1,5	170	30	-	32	24	6	40,5	A42150...
42	2	170	30	-	32	24	5	40	A42200...
42	3	200	60	-	32	24	5	39	A42300...
45	1,5	180	32	-	36	29	6	43,5	A45150...
45	2	180	32	-	36	29	5	43	A45200...
45	3	200	50	-	36	29	5	42	A45300...
48	1,5	190	32	-	36	29	6	46,5	A48150...
48	2	190	32	-	36	29	6	46	A48200...
48	3	225	50	-	36	29	5	45	A48300...



A71S
BRIGHT

A71S
VAP

A71S
TiN

A71S
TiCN

A SERIES

DIN 374

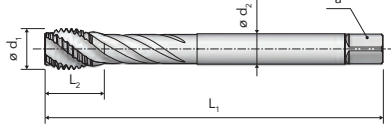

APPLICATION RANGE - CUTTING SPEED m/min

ISO	MG	A71S BRIGHT	A71S VAP	A71S TiN	A71S TiCN
P	P.2	● 15-20	● 15-20	● 25-30	● 25-30
	P.3	● 12-15	● 12-15	● 20-25	● 20-25
	P.4	● 10-12	● 10-12	● 15-20	● 15-20
	P.5			● 5-10	● 5-10
	P.7			● 6-8	● 6-8
M	M.1			● 6-8	● 6-8
K	K.2	● 12-15	● 12-15	● 20-25	● 20-25
N	N.3	● 15-18	● 15-18	● 25-30	● 25-30
	N.6	● 15-18	● 15-18	● 25-30	● 25-30



$\varnothing d_1$	P	L_1 js 16	L_2	L_3	$\varnothing d_2$ h9	a h12	z		A71S BRIGHT ...0712B1AA0	A71S VAP ...0712B1AB0	A71S TiN ...0712B1AD0	A71S TiCN ...0712B1AE0
[mm]	[mm]	[mm]	[mm]	[mm]	[mm]	[mm]	[-]	[mm]				
M 3	0,35	56	5	-	2,2	-	3	2,65	A03035...		A03035...	
4	0,5	63	6	-	2,8	2,1	3	3,5	A04050...		A04050...	
5	0,5	70	7,5	-	3,5	2,7	3	4,5	A05050...		A05050...	
6	0,5	80	7,5	-	4,5	3,4	3	5,5	A06050...		A06050...	
6	0,75	80	7,5	-	4,5	3,4	3	5,2	A06075...	A06075...	A06075...	A06075...
6,5	0,75	80	8	-	5,5	4,3	3	5,8	A06575...		A06575...	
8	0,75	80	10	-	6	4,9	3	7,2	A08075...		A08075...	
8	1	90	10	-	6	4,9	3	7	A08100...	A08100...	A08100...	A08100...
10	1	90	10	-	7	5,5	3	9	A10100...	A10100...	A10100...	A10100...
10	1,25	100	11,5	-	7	5,5	3	8,8	A10125...	A10125...	A10125...	A10125...
12	1	100	13	-	9	7	4	11	A12100...	A12100...	A12100...	A12100...
12	1,25	100	13,5	-	9	7	4	10,8	A12125...	A12125...	A12125...	A12125...
12	1,5	100	14	-	9	7	4	10,5	A12150...	A12150...	A12150...	A12150...
14	1,5	100	15,5	-	11	9	4	12,5	A14150...	A14150...	A14150...	A14150...
16	1,5	100	15,5	-	12	9	4	14,5	A16150...	A16150...	A16150...	A16150...
18	1,5	110	16	-	14	11	4	16,5	A18150...	A18150...	A18150...	A18150...
20	1	125	15	-	16	12	4	19	A20100...			
20	1,5	125	17	-	16	12	4	18,5	A20150...	A20150...	A20150...	A20150...
22	1,5	125	19	-	18	14,5	4	20,5	A22150...	A22150...	A22150...	A22150...
24	1,5	140	21	-	18	14,5	4	22,5	A24150...		A24150...	
24	2	140	26	-	18	14,5	4	22	A24200...			
26	1,5	140	23	-	18	14,5	4	24,5	A26150...			
27	1,5	140	23	-	20	16	4	25,5	A27150...		A27150...	
27	2	140	28	-	20	16	4	25	A27200...			
28	1,5	140	23	-	20	16	4	26,5	A28150...			
30	1,5	150	25	-	22	18	5	28,5	A30150...		A30150...	





A71 S
BRIGHT

DIN 374

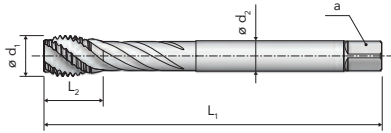

A SERIES

APPLICATION RANGE - CUTTING SPEED m/min

ISO	MG	A71 S BRIGHT			
P	P.2	• 15-20			
	P.3	• 12-15			
	P.4	• 10-12			
K	K.2	• 12-15			
N	N.3	• 15-18			
	N.6	• 15-18			



<<

Ød ₁	P	L ₁ js16	L ₂	L ₃	Ød ₂ h9	a h12	Z	z	A71 S BRIGHT ...0712B1AA0
[mm]	[mm]	[mm]	[mm]	[mm]	[mm]	[mm]	[-]	[mm]	
M 30	2	150	29	-	22	18	5	28	A30200...
36	3	200	46	-	28	22	5	33	A36300...
42	3	200	51	-	32	24	6	39	A42300...



A71S
TiX2

A SERIES

DIN 374

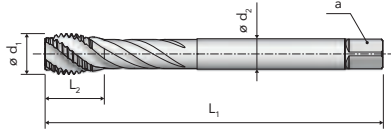

APPLICATION RANGE - CUTTING SPEED m/min

ISO	MG	A71S TiX2			
P	P.7	• 6-8			
M	M.1	• 6-8			



Ød ₁	P	L ₁ js 16	L ₂	L ₃	Ød ₂ h9	a h12	Z	z	A71S TiX2 ...0712B1ALO
[mm]	[mm]	[mm]	[mm]	[mm]	[mm]	[mm]	[-]	[mm]	
M 6	0,75	80	7,5	-	4,5	3,4	3	5,2	A06075...
8	1	90	10	-	6	4,9	3	7	A08100...
10	1	90	10	-	7	5,5	3	9	A10100...
10	1,25	100	11,5	-	7	5,5	3	8,8	A10125...
12	1,25	100	13,5	-	9	7	4	10,8	A12125...
12	1,5	100	14	-	9	7	4	10,5	A12150...
14	1,5	100	15,5	-	11	9	4	12,5	A14150...
16	1,5	100	15,5	-	12	9	4	14,5	A16150...
20	1,5	125	17	-	16	12	4	18,5	A20150...



A71 S 6G
BRIGHT

A71 S 6G
TiN

DIN 374

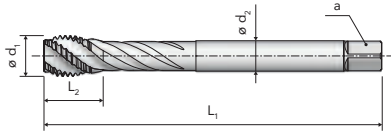

A SERIES

APPLICATION RANGE - CUTTING SPEED m/min

ISO	MG	A71 S 6G BRIGHT	A71 S 6G TiN
P	P.2	● 15-20	● 25-30
	P.3	● 12-15	● 20-25
	P.4	● 10-12	● 15-20
	P.5		● 5-10
	P.7		● 6-8
M	M.1		● 6-8
K	K.2	● 12-15	● 20-25
N	N.3	● 15-18	● 25-30
	N.6	● 15-18	● 25-30



$\varnothing d_1$	P	L_1 js16	L_2	L_3	$\varnothing d_2$ h9	a h12	Z		A71 S 6G BRIGHT ...0712B1CA0	A71 S 6G TiN ...0712B1CDO
[mm]	[mm]	[mm]	[mm]	[mm]	[mm]	[mm]	[-]	[mm]		
M 6	0,75	80	7,5	-	4,5	3,4	3	5,2	A06075...	A06075...
8	1	90	10	-	6	4,9	3	7	A08100...	A08100...
10	1	90	10	-	7	5,5	3	9	A10100...	A10100...
10	1,25	100	11,5	-	7	5,5	3	8,8	A10125...	A10125...
12	1	100	13	-	9	7	4	11	A12100...	A12100...
12	1,25	100	13,5	-	9	7	4	10,8	A12125...	A12125...
12	1,5	100	14	-	9	7	4	10,5	A12150...	A12150...
14	1,5	100	15,5	-	11	9	4	12,5	A14150...	A14150...



A10
BRIGHT

A SERIES

NORM VERGNANO

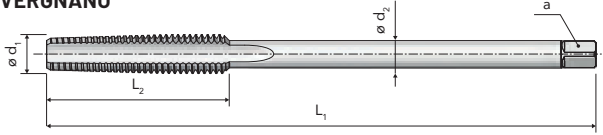

APPLICATION RANGE - CUTTING SPEED m/min

ISO	MG	A10 BRIGHT			
P	P.1	• 18-20			
	P.2	• 15-18			
	P.3	• 12-15			

ISO2
6H



RH

Ød ₁	P	L ₁ js 16	L ₂	L ₃	Ød ₂ h9	a h12	Z		A10 BRIGHT ...0101A2AA0
[mm]	[mm]	[mm]	[mm]	[mm]	[mm]	[mm]	[-]	[mm]	
M 4	0,5	80	20	-	2,8	2,1	3	3,5	A04050...
5	0,5	85	22	-	3,5	2,7	3	4,5	A05050...
8	1	115	30	-	6	4,9	3	7	A08100...
10	1	130	35	-	7	5,5	3	9	A10100...
10	1,25	140	45	-	7	5,5	3	8,8	A10125...
12	1,25	160	45	-	9	7	3	10,8	A12125...
12	1,5	160	45	-	9	7	3	10,5	A12150...
14	1,5	180	45	-	11	9	3	12,5	A14150...
16	1,5	190	48	-	12	9	3	14,5	A16150...
18	1,5	200	48	-	14	11	3	16,5	A18150...
20	1,5	220	50	-	16	12	3	18,5	A20150...



A81
TiN

A81 6GX
TiN

DIN 2174 (371)
≤ M10x1,25

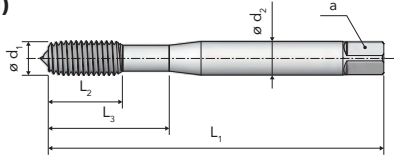

DIN 2174 (374)
≥ M12x1

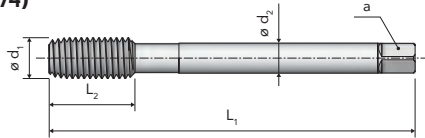

APPLICATION RANGE - CUTTING SPEED m/min

ISO	MG	A81 TiN	A81 6GX TiN
P	P.1-2	• 20-25	• 20-25
	P.3	• 15-20	• 15-20
N	N.1-2	• 20-25	• 20-25
	N.3	• 15-20	• 15-20
	N.5-6	• 20-25	• 20-25



$\varnothing d_1$	P	L_1 js16	L_2	L_3	$\varnothing d_2$ h9	a h12	Z		A81 TiN	A81 6GX TiN
[mm]	[mm]	[mm]	[mm]	[mm]	[mm]	[mm]	[-]	[mm]	...0812A1A00	...0812A1C00
M 3	0,35	56	10	18	3,5	2,7	4	2,85	A03035...	A03035...
4	0,5	63	12	21	4,5	3,4	5	3,8	A04050...	A04050...
5	0,5	70	14	24,5	6	4,9	5	4,8	A05050...	A05050...
6	0,75	80	16	29	6	4,9	5	5,65	A06075...	A06075...
8	1	90	18	33	8	6,2	5	7,55	A08100...	A08100...
10	1	90	18	34	10	8	6	9,55	A10100...	A10100...
10	1,25	100	20	36	10	8	6	9,4	A10125...	A10125...
12	1	100	22	-	9	7	6	11,55	A12100...	A12100...
12	1,25	100	22	-	9	7	6	11,4	A12125...	A12125...
12	1,5	100	22	-	9	7	6	11,3	A12150...	A12150...
14	1,25	100	22	-	11	9	6	13,4	A14125...	A14125...
14	1,5	100	22	-	11	9	6	13,3	A14150...	A14150...
16	1,5	100	22	-	12	9	6	15,3	A16150...	A16150...

A SERIES



HSSE

A81N
TiN

A81N 6GX
TiN

A SERIES

DIN 2174 (371)
≤ M10x1,25

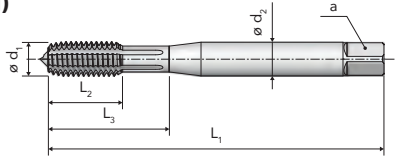

DIN 2174 (374)
≥ M12x1

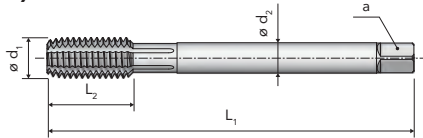

APPLICATION RANGE - CUTTING SPEED m/min

ISO	MG	A81N TiN	A81N 6GX TiN
P	P.1-2	• 20-25	• 20-25
	P.3	• 15-20	• 15-20
N	N.1-2	• 20-25	• 20-25
	N.3	• 15-20	• 15-20
	N.5-6	• 20-25	• 20-25



Ød ₁	P	L ₁ js 16	L ₂	L ₃	Ød ₂ h9	a h12	Z		A81N TiN ...0812G1ADO	A81N 6GX TiN ...0812G1CDO
[mm]	[mm]	[mm]	[mm]	[mm]	[mm]	[mm]	[-]	[mm]		
M 3	0,35	56	10	18	3,5	2,7	4	2,85	A03035...	A03035...
4	0,5	63	12	21	4,5	3,4	5	3,8	A04050...	A04050...
5	0,5	70	14	24,5	6	4,9	5	4,8	A05050...	A05050...
6	0,75	80	16	29	6	4,9	5	5,65	A06075...	A06075...
8	1	90	18	33	8	6,2	5	7,55	A08100...	A08100...
10	1	90	18	34	10	8	6	9,55	A10100...	A10100...
10	1,25	100	20	36	10	8	6	9,4	A10125...	A10125...
12	1	100	22	-	9	7	6	11,55	A12100...	A12100...
12	1,25	100	22	-	9	7	6	11,4	A12125...	A12125...
12	1,5	100	22	-	9	7	6	11,3	A12150...	A12150...
14	1,25	100	22	-	11	9	6	13,4	A14125...	A14125...
14	1,5	100	22	-	11	9	6	13,3	A14150...	A14150...
16	1,5	100	22	-	12	9	6	15,3	A16150...	A16150...
18	1,5	110	22	-	14	11	8	17,3	A18150...	A18150...
20	1,5	125	25	-	16	12	8	19,3	A20150...	A20150...



A7
ROUGHING

A7
SECOND

A7
FINISHING

A7
SET

DIN 2184-2
≤ Ø 1/4"

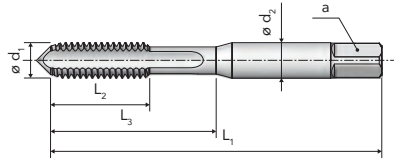

DIN 2184-2
≥ Ø 5/16"

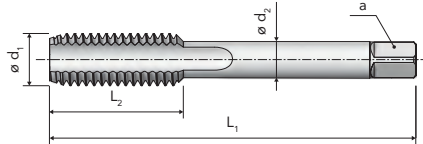

A SERIES

APPLICATION RANGE - CUTTING SPEED m/min

ISO	MG	A7 ROUGHING	A7 SECOND	A7 FINISHING	A7 SET
P	P.1-4	•	•	•	•
	P.7	•	•	•	•
K	K.2	•	•	•	•
N	N.1-3	•	•	•	•
	N.5-7	•	•	•	•

—	—	2B	2B

UNC	P	Ød ₁	L ₁ js16	L ₂	L ₃	Ød ₂ h9	a h12	z		A7 ROUGHING ...0071A1MA0	A7 SECOND ...0071A2MA0	A7 FINISHING ...0071A3MA0	A7 SET ...0071A5MA0
Nr.1	64	1,854	36	7,5	12	2,8	2,1	3	1,55	AH0164...	AH0164...	AH0164...	AH0164...
Nr.2	56	2,184	36	8,5	13,5	2,8	2,1	3	1,85	AH0256...	AH0256...	AH0256...	AH0256...
Nr.3	48	2,515	40	8,5	14,5	2,8	2,1	3	2,1	AH0348...	AH0348...	AH0348...	AH0348...
Nr.4	40	2,845	40	10	18	3,5	2,7	3	2,35	AH0440...	AH0440...	AH0440...	AH0440...
Nr.5	40	3,175	40	10	18	3,5	2,7	3	2,65	AH0540...	AH0540...	AH0540...	AH0540...
Nr.6	32	3,505	45	11	20	4	3	3	2,85	AH0632...	AH0632...	AH0632...	AH0632...
Nr.8	32	4,166	45	12	21	4,5	3,4	3	3,5	AH0832...	AH0832...	AH0832...	AH0832...
Nr.10	24	4,826	50	14	23	6	4,9	3	3,9	AH1024...	AH1024...	AH1024...	AH1024...
Nr.12	24	5,486	56	16	28	6	4,9	3	4,5	AH1224...	AH1224...	AH1224...	AH1224...
1/4"	20	6,35	56	16	28	6	4,9	3	5,1	AHA140...	AHA140...	AHA140...	AHA140...
5/16"	18	7,938	63	22	-	6	4,9	3	6,6	AHB516...	AHB516...	AHB516...	AHB516...
3/8"	16	9,525	70	24	-	7	5,5	3	8	AHC380...	AHC380...	AHC380...	AHC380...
7/16"	14	11,113	70	24	-	8	6,2	3	9,4	AHD716...	AHD716...	AHD716...	AHD716...
1/2"	13	12,7	75	28	-	9	7	3	10,8	AHE120...	AHE120...	AHE120...	AHE120...
9/16"	12	14,288	80	28	-	11	9	4	12,2	AHF916...	AHF916...	AHF916...	AHF916...
5/8"	11	15,875	80	30	-	12	9	4	13,5	AHG580...	AHG580...	AHG580...	AHG580...
3/4"	10	19,05	95	32	-	14	11	4	16,5	AHH340...	AHH340...	AHH340...	AHH340...
7/8"	9	22,225	100	32	-	18	14,5	4	19,5	AHL780...	AHL780...	AHL780...	AHL780...
1"	8	25,4	110	36	-	18	14,5	4	22,25	AHM100...	AHM100...	AHM100...	AHM100...
1 1/8"	7	28,575	125	40	-	22	18	4	25	AHN118...	AHN118...	AHN118...	AHN118...
1 1/4"	7	31,75	125	40	-	22	18	4	28	AHP114...	AHP114...	AHP114...	AHP114...



A27 FC
BRIGHT

A27 FC
TiN

A27 FP
BRIGHT

A27 FP
TiN

A SERIES

DIN 2184-1
≤ Ø 1/4"

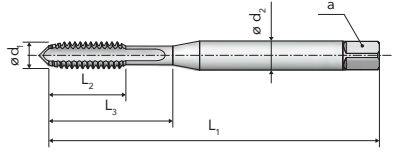

DIN 2184-1
≥ Ø 5/16"

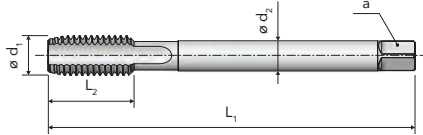

APPLICATION RANGE - CUTTING SPEED m/min

ISO	MG	A27 FC BRIGHT	A27 FC TiN	A27 FP BRIGHT	A27 FP TiN
P	P.1		● 20-25		● 20-25
	P.2	● 10-12	● 15-20	● 10-12	● 15-20
	P.3	● 8-10	● 12-15	● 8-10	● 12-15
K	K.2	● 8-10	● 12-15	● 8-10	● 12-15
N	N.1		● 20-25		● 20-25
	N.5		● 15-20		● 15-20



UNC	P	Ød ₁	L ₁ js16	L ₂	L ₃	Ød ₂ h9	a h12	z		A27 FC BRIGHT ...0272A1MA0	A27 FC TiN ...0272A1MD0	A27 FP BRIGHT ...0272A2MA0	A27 FP TiN ...0272A2MD0
Nr.2	56	2,184	45	9	13	2,8	2,1	3	1,85	AH0256...	AH0256...	AH0256...	AH0256...
Nr.3	48	2,515	50	9	15	2,8	2,1	3	2,1	AH0348...	AH0348...	AH0348...	AH0348...
Nr.4	40	2,845	56	10	18	3,5	2,7	3	2,35	AH0440...	AH0440...	AH0440...	AH0440...
Nr.5	40	3,175	56	10	18	3,5	2,7	3	2,65	AH0540...	AH0540...	AH0540...	AH0540...
Nr.6	32	3,505	56	11	20	4	3	3	2,85	AH0632...	AH0632...	AH0632...	AH0632...
Nr.8	32	4,166	63	13	22	4,5	3,4	3	3,5	AH0832...	AH0832...	AH0832...	AH0832...
Nr.10	24	4,826	70	16	26,5	6	4,9	3	3,9	AH1024...	AH1024...	AH1024...	AH1024...
Nr.12	24	5,486	80	16	26,5	6	4,9	3	4,5	AH1224...	AH1224...	AH1224...	AH1224...
1/4"	20	6,35	80	17	30	7	5,5	3	5,1	AHA140...	AHA140...	AHA140...	AHA140...
5/16"	18	7,938	90	18	-	6	4,9	3	6,6	AHB516...	AHB516...	AHB516...	AHB516...
3/8"	16	9,525	100	22	-	7	5,5	3	8	AHC380...	AHC380...	AHC380...	AHC380...
7/16"	14	11,113	100	24	-	8	6,2	3	9,4	AHD716...	AHD716...	AHD716...	AHD716...
1/2"	13	12,7	110	26	-	9	7	3	10,8	AHE120...	AHE120...	AHE120...	AHE120...
9/16"	12	14,288	110	28	-	11	9	3	12,2	AHF916...	AHF916...	AHF916...	AHF916...
5/8"	11	15,875	110	28	-	12	9	3	13,5	AHG580...	AHG580...	AHG580...	AHG580...
3/4"	10	19,05	125	32	-	14	11	4	16,5	AHH340...	AHH340...	AHH340...	AHH340...
7/8"	9	22,225	140	32	-	18	14,5	4	19,5	AHL780...	AHL780...	AHL780...	AHL780...
1"	8	25,4	160	36	-	18	14,5	4	22,25	AHM100...	AHM100...	AHM100...	AHM100...
1 1/8"	7	28,575	180	40	-	22	18	4	25	AHN118...			
1 1/4"	7	31,75	180	40	-	22	18	4	28	AHP114...		AHP114...	
1 3/8"	6	34,925	200	50	-	28	22	4	30,75	AHQ138...		AHQ138...	
1 1/2"	6	38,1	200	50	-	28	22	4	34	AHR112...		AHR112...	



HSSE

A49
NITRIDED

A49
TiCN

DIN 2184-1
≤ Ø 1/4"

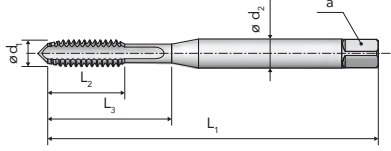

DIN 2184-1
≥ Ø 5/16"

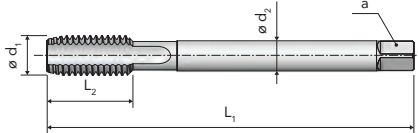

A
SERIES

APPLICATION RANGE - CUTTING SPEED m/min

ISO	MG	A49 NITRIDED	A49 TiCN
K	K.1	• 15-20	• 40-45
N	N.4	• 15-20	• 40-45
	N.7	• 15-20	• 40-45
	N.9-10	• 20-25	• 45-50

2BX

2BX



UNC	P [TPI]	Ød ₁ [mm]	L ₁ js16 [mm]	L ₂ [mm]	L ₃ [mm]	Ød ₂ h9 [mm]	a h12 [mm]	z	z	z	A49 NITRIDED ...0492A1MCO	A49 TiCN ...0492A1ME0
Nr.2	56	2,184	45	9	13	2,8	2,1	3	1,85		AH0256...	AH0256...
Nr.3	48	2,515	50	9	15	2,8	2,1	3	2,1		AH0348...	AH0348...
Nr.4	40	2,845	56	10	18	3,5	2,7	3	2,35		AH0440...	AH0440...
Nr.5	40	3,175	56	10	18	3,5	2,7	3	2,65		AH0540...	AH0540...
Nr.6	32	3,505	56	11	20	4	3	3	2,85		AH0632...	AH0632...
Nr.8	32	4,166	63	13	22	4,5	3,4	3	3,5		AH0832...	AH0832...
Nr.10	24	4,826	70	16	26,5	6	4,9	3	3,9		AH1024...	AH1024...
Nr.12	24	5,486	80	16	26,5	6	4,9	3	4,5		AH1224...	AH1224...
1/4"	20	6,35	80	17	30	7	5,5	3	5,1		AHA140...	AHA140...
5/16"	18	7,938	90	18	-	6	4,9	4	6,6		AHB516...	AHB516...
3/8"	16	9,525	100	22	-	7	5,5	4	8		AHC380...	AHC380...
7/16"	14	11,113	100	24	-	8	6,2	4	9,4		AHD716...	AHD716...
1/2"	13	12,7	110	26	-	9	7	4	10,8		AHE120...	AHE120...
9/16"	12	14,288	110	28	-	11	9	4	12,2		AHF916...	AHF916...
5/8"	11	15,875	110	28	-	12	9	4	13,5		AHG580...	AHG580...
3/4"	10	19,05	125	32	-	14	11	4	16,5		AHH340...	AHH340...
7/8"	9	22,225	140	32	-	18	14,5	4	19,5		AHL780...	AHL780...
1"	8	25,4	160	36	-	18	14,5	5	22,25		AHM100...	AHM100...
1 1/8"	7	28,575	180	40	-	22	18	5	25		AHN118...	
1 1/4"	7	31,75	180	40	-	22	18	5	28		AHP114...	
1 3/8"	6	34,925	200	50	-	28	22	5	30,75		AHQ138...	
1 1/2"	6	38,1	200	50	-	28	22	5	34		AHR112...	





A19 S
BRIGHT

A19 S
TiN

A19 S
TiCN

A19 S 3B
BRIGHT

A SERIES

DIN 2184-1
≤ Ø 1/4"

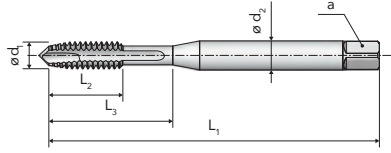

DIN 2184-1
≥ Ø 5/16"

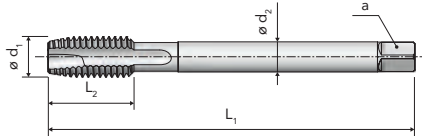

APPLICATION RANGE - CUTTING SPEED m/min

ISO	MG	A19 S BRIGHT	A19 S TiN	A19 S TiCN	A19 S 3B BRIGHT
P	P.2	● 20-25	● 30-35	● 30-35	● 20-25
	P.3	● 15-20	● 25-30	● 25-30	● 15-20
	P.4	● 12-15	● 20-25	● 20-25	● 12-15
	P.5		● 10-15	● 10-15	
M	M.1		● 8-10	● 8-10	
	K.2	● 15-20	● 25-30	● 25-30	● 15-20
N	N.2-3	● 20-25	● 30-35	● 30-35	● 20-25
	N.6	● 15-18	● 25-30	● 25-30	● 15-18



UNC	P	Ød ₁	L ₁ js 16	L ₂	L ₃	Ød ₂ h9	a h12	z		A19 S BRIGHT ...0192B2MA0	A19 S TiN ...0192B2MD0	A19 S TiCN ...0192B2ME0	A19 S 3B BRIGHT ...0192B2NA0
Nr.2	56	2,184	45	8	13	2,8	2,1	2	1,85	AH0256...	AH0256...	AH0256...	
Nr.3	48	2,515	50	9	15	2,8	2,1	3	2,1	AH0348...	AH0348...	AH0348...	
Nr.4	40	2,845	56	10	18	3,5	2,7	3	2,35	AH0440...	AH0440...	AH0440...	
Nr.5	40	3,175	56	10	18	3,5	2,7	3	2,65	AH0540...	AH0540...	AH0540...	
Nr.6	32	3,505	56	11	20	4	3	3	2,85	AH0632...	AH0632...	AH0632...	AH0632...
Nr.8	32	4,166	63	13	22	4,5	3,4	3	3,5	AH0832...	AH0832...	AH0832...	AH0832...
Nr.10	24	4,826	70	16	26,5	6	4,9	3	3,9	AH1024...	AH1024...	AH1024...	AH1024...
Nr.12	24	5,486	80	16	26,5	6	4,9	3	4,5	AH1224...	AH1224...	AH1224...	AH1224...
1/4"	20	6,35	80	17	30	7	5,5	3	5,1	AHA140...	AHA140...	AHA140...	AHA140...
5/16"	18	7,938	90	18	-	6	4,9	3	6,6	AHB516...	AHB516...	AHB516...	AHB516...
3/8"	16	9,525	100	22	-	7	5,5	3	8	AHC380...	AHC380...	AHC380...	AHC380...
7/16"	14	11,113	100	24	-	8	6,2	3	9,4	AHD716...	AHD716...	AHD716...	AHD716...
1/2"	13	12,7	110	26	-	9	7	3	10,8	AHE120...	AHE120...	AHE120...	AHE120...
9/16"	12	14,288	110	28	-	11	9	3	12,2	AHF916...	AHF916...	AHF916...	AHF916...
5/8"	11	15,875	110	28	-	12	9	3	13,5	AHG580...	AHG580...	AHG580...	AHG580...
3/4"	10	19,05	125	32	-	14	11	4	16,5	AHH340...	AHH340...	AHH340...	AHH340...
7/8"	9	22,225	140	32	-	18	14,5	4	19,5	AHL780...	AHL780...	AHL780...	AHL780...
1"	8	25,4	160	36	-	18	14,5	4	22,25	AHM100...	AHM100...	AHM100...	
1 1/4"	7	31,75	180	40	-	22	18	4	28	AHP114...			
1 1/2"	6	38,1	200	50	-	28	22	4	34	AHR112...			

MACHINE TAPS for through holes
Straight flutes with spiral point / for stainless steel



A19 S
TiX2

DIN 2184-1
≤ Ø 1/4"

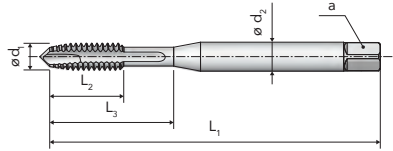

DIN 2184-1
≥ Ø 5/16"

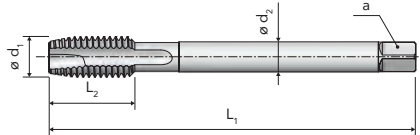

A SERIES

APPLICATION RANGE - CUTTING SPEED m/min

ISO	MG	A19 S TiX2			
P	P.7	• 10-12			
M	M.1	• 10-12			



UNC	P	Ød ₁	L ₁ js16	L ₂	L ₃	Ød ₂ h9	a h12	z	z	z	A19 S TiX2 ...0192B2MLO
	[TPI]	[mm]	[mm]	[mm]	[mm]	[mm]	[mm]	[-]	[mm]	[mm]	
Nr.6	32	3,505	56	11	20	4	3	3	2,85		AH0632...
Nr.8	32	4,166	63	13	22	4,5	3,4	3	3,5		AH0832...
Nr.10	24	4,826	70	16	26,5	6	4,9	3	3,9		AH1024...
Nr.12	24	5,486	80	16	26,5	6	4,9	3	4,5		AH1224...
1/4"	20	6,35	80	17	30	7	5,5	3	5,1		AHA140...
5/16"	18	7,938	90	18	-	6	4,9	3	6,6		AHB516...
3/8"	16	9,525	100	22	-	7	5,5	3	8		AHC380...
7/16"	14	11,113	100	24	-	8	6,2	3	9,4		AHD716...
1/2"	13	12,7	110	26	-	9	7	3	10,8		AHE120...
9/16"	12	14,288	110	28	-	11	9	3	12,2		AHF916...
5/8"	11	15,875	110	28	-	12	9	3	13,5		AHG580...
3/4"	10	19,05	125	32	-	14	11	4	16,5		AHH340...
7/8"	9	22,225	140	32	-	18	14,5	4	19,5		AHL780...
1"	8	25,4	160	36	-	18	14,5	4	22,25		AHM100...



A33
BRIGHT

A33
TiN

A33 3B
BRIGHT

A SERIES

DIN 2184-1
≤ Ø 1/4"

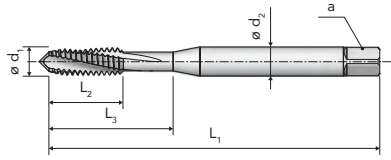

DIN 2184-1
≥ Ø 5/16"

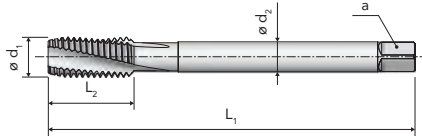

APPLICATION RANGE - CUTTING SPEED m/min

ISO	MG	A33 BRIGHT	A33 TiN	A33 3B BRIGHT
P	P.1	● 18-20	● 30-35	● 18-20
	P.2	● 15-18	● 25-30	● 15-18
	P.3	● 12-15	● 20-25	● 12-15
	P.4	● 10-12	● 15-20	● 10-12
	P.5		● 5-10	
K	K.2	● 12-15	● 20-25	● 12-15
N	N.1	● 18-20		● 18-20
	N.2-3	● 15-18	● 25-30	● 15-18
	N.5	● 15-18		● 15-18
	N.6	● 12-15	● 20-25	● 12-15



UNC	P	Ød ₁	L ₁ js 16	L ₂	L ₃	Ød ₂ h9	a h12	z		A33 BRIGHT ...0332A1MA0	A33 TiN ...0332A1MD0	A33 3B BRIGHT ...0332A1NA0
Nr.2	56	2,184	45	8	13	2,8	2,1	3	1,85	AH0256...	AH0256...	
Nr.3	48	2,515	50	9	15	2,8	2,1	3	2,1	AH0348...	AH0348...	
Nr.4	40	2,845	56	10	18	3,5	2,7	3	2,35	AH0440...	AH0440...	
Nr.5	40	3,175	56	10	18	3,5	2,7	3	2,65	AH0540...	AH0540...	
Nr.6	32	3,505	56	11	20	4	3	3	2,85	AH0632...	AH0632...	AH0632...
Nr.8	32	4,166	63	13	20	4,5	3,4	3	3,5	AH0832...	AH0832...	AH0832...
Nr.10	24	4,826	70	16	26,5	6	4,9	3	3,9	AH1024...	AH1024...	AH1024...
Nr.12	24	5,486	80	16	29	6	4,9	3	4,5	AH1224...	AH1224...	AH1224...
1/4"	20	6,35	80	17	30	7	5,5	3	5,1	AHA140...	AHA140...	AHA140...
5/16"	18	7,938	90	18	-	6	4,9	3	6,6	AHB516...	AHB516...	AHB516...
3/8"	16	9,525	100	22	-	7	5,5	3	8	AHC380...	AHC380...	AHC380...
7/16"	14	11,113	100	24	-	8	6,2	3	9,4	AHD716...	AHD716...	AHD716...
1/2"	13	12,7	110	26	-	9	7	3	10,8	AHE120...	AHE120...	AHE120...
9/16"	12	14,288	110	28	-	11	9	3	12,2	AHF916...	AHF916...	AHF916...
5/8"	11	15,875	110	28	-	12	9	3	13,5	AHG580...	AHG580...	AHG580...
3/4"	10	19,05	125	32	-	14	11	4	16,5	AHH340...	AHH340...	AHH340...
7/8"	9	22,225	140	32	-	18	14,5	4	19,5	AHL780...	AHL780...	
1"	8	25,4	160	36	-	18	14,5	4	22,25	AHM100...	AHM100...	
1 1/8"	7	28,575	180	40	-	22	18	4	25	AHN118...		
1 1/4"	7	31,75	180	40	-	22	18	4	28	AHP114...		
1 3/8"	6	34,925	200	50	-	28	22	4	30,75	AHQ138...		
1 1/2"	6	38,1	200	50	-	28	22	4	34	AHR112...		



A60 S
BRIGHT

A60 S
TiN

A60 S
TiCN

A60 S
TiX2

DIN 2184-1
≤ Ø 1/4"

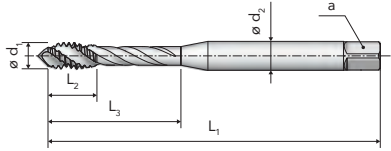

DIN 2184-1
≥ Ø 5/16"

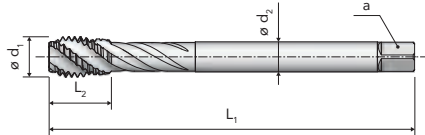

A
SERIES

APPLICATION RANGE - CUTTING SPEED m/min

ISO	MG	A60 S BRIGHT	A60 S TiN	A60 S TiCN	A60 S TiX2
P	P.2	● 15-20	● 25-30	● 25-30	
	P.3	● 12-15	● 20-25	● 20-25	
	P.4	● 10-12	● 15-20	● 15-20	
	P.5		● 5-10	● 5-10	
	P.7		● 6-8	● 6-8	● 6-8
M	M.1		● 6-8	● 6-8	● 6-8
K	K.2	● 12-15	● 20-25	● 20-25	
N	N.3	● 15-18	● 25-30	● 25-30	
	N.6	● 15-18	● 25-30	● 25-30	



UNC	P	Ød ₁	L ₁ js16	L ₂	L ₃	Ød ₂ h9	a h12	z		A60 S BRIGHT ...0602B1MA0	A60 S TiN ...0602B1M00	A60 S TiCN ...0602B1M00	A60 S TiX2 ...0602B1M00
	[TPI]	[mm]	[mm]	[mm]	[mm]	[mm]	[mm]	[-]	[mm]				
Nr.2	56	2,184	45	6	13	2,8	2,1	3	1,85	AH0256...	AH0256...	AH0256...	AH0256...
Nr.3	48	2,515	50	6	15	2,8	2,1	3	2,1	AH0348...	AH0348...	AH0348...	AH0348...
Nr.4	40	2,845	56	6,5	21	3,5	2,7	3	2,35	AH0440...	AH0440...	AH0440...	AH0440...
Nr.5	40	3,175	56	6,5	21	3,5	2,7	3	2,65	AH0540...	AH0540...	AH0540...	AH0540...
Nr.6	32	3,505	56	7,5	22,5	4	3	3	2,85	AH0632...	AH0632...	AH0632...	AH0632...
Nr.8	32	4,166	63	7,5	26	4,5	3,4	3	3,5	AH0832...	AH0832...	AH0832...	AH0832...
Nr.10	24	4,826	70	10	28,5	6	4,9	3	3,9	AH1024...	AH1024...	AH1024...	AH1024...
Nr.12	24	5,486	80	10	28,5	6	4,9	3	4,5	AH1224...	AH1224...	AH1224...	AH1224...
1/4"	20	6,35	80	11,5	32	7	5,5	3	5,1	AHA140...	AHA140...	AHA140...	AHA140...
5/16"	18	7,938	90	13	-	6	4,9	3	6,6	AHB516...	AHB516...	AHB516...	AHB516...
3/8"	16	9,525	100	14	-	7	5,5	3	8	AHC380...	AHC380...	AHC380...	AHC380...
7/16"	14	11,113	100	17	-	8	6,2	3	9,4	AHD716...	AHD716...	AHD716...	AHD716...
1/2"	13	12,7	110	19	-	9	7	4	10,8	AHE120...	AHE120...	AHE120...	AHE120...
9/16"	12	14,288	110	21	-	11	9	4	12,2	AHF916...	AHF916...	AHF916...	AHF916...
5/8"	11	15,875	110	22,5	-	12	9	4	13,5	AHG580...	AHG580...	AHG580...	AHG580...
3/4"	10	19,05	125	26	-	14	11	4	16,5	AHH340...	AHH340...	AHH340...	AHH340...
7/8"	9	22,225	140	30	-	18	14,5	4	19,5	AHL780...	AHL780...	AHL780...	AHL780...
1"	8	25,4	160	36,5	-	18	14,5	4	22,25	AHM100...	AHM100...	AHM100...	AHM100...
1 1/4"	7	31,75	180	42	-	22	18	5	28	AHP114...			
1 1/2"	6	38,1	200	49	-	28	22	5	34	AHR112...			



A65
BRIGHT

A SERIES

DIN 2184-1
≤ Ø 1/4"

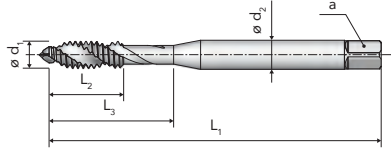

DIN 2184-1
≥ Ø 5/16"

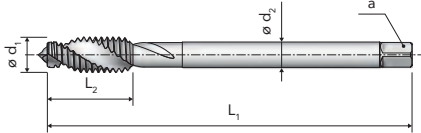

APPLICATION RANGE - CUTTING SPEED m/min

ISO	MG	A65 BRIGHT			
N	N.1-2	• 12-15			
	N.5-6	• 10-12			
S	S.1	• 6-8			
	S.3	• 6-8			



UNC	P	Ød ₁	L ₁ js 16	L ₂	L ₃	Ød ₂ h9	a h12	Z	z	z	A65 BRIGHT ...0652A1MA0
	[TPI]	[mm]	[mm]	[mm]	[mm]	[mm]	[mm]	[-]	[mm]	[mm]	
Nr.3	48	2,515	50	9	15	2,8	2,1	2	2,1	2,1	AH0348...
Nr.4	40	2,845	56	10	18	3,5	2,7	2	2,35	2,35	AH0440...
Nr.5	40	3,175	56	10	18	3,5	2,7	2	2,65	2,65	AH0540...
Nr.6	32	3,505	56	11	20	4	3	2	2,85	2,85	AH0632...
Nr.8	32	4,166	63	13	20	4,5	3,4	2	3,5	3,5	AH0832...
Nr.10	24	4,826	70	16	26,5	6	4,9	2	3,9	3,9	AH1024...
Nr.12	24	5,486	80	16	29	6	4,9	2	4,5	4,5	AH1224...
1/4"	20	6,35	80	17	30	7	5,5	2	5,1	5,1	AHA140...
5/16"	18	7,938	90	18	-	6	4,9	2	6,6	6,6	AHB516...
3/8"	16	9,525	100	22	-	7	5,5	2	8	8	AHC380...

HAND TAPS for blind and through holes
In sets of two pieces



A8
ROUGHING

A8
FINISHING

A8
SET

DIN 2184-2
≤ Ø 1/4"

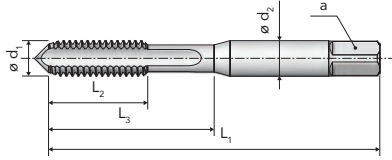

DIN 2184-2
≥ Ø 5/16"

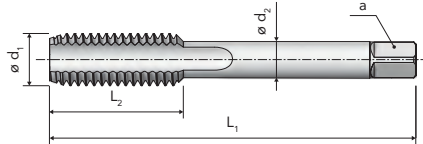

A SERIES

APPLICATION RANGE - CUTTING SPEED m/min

ISO	MG	A8 ROUGHING	A8 FINISHING	A8 SET
P	P.1-4	•	•	•
	P.7	•	•	•
K	K.2	•	•	•
N	N.1-3	•	•	•
	N.5-7	•	•	•

—

2B **2B**

A (5-6) C (2-3) C (2-3)

2,5xD 2,5xD 2,5xD

RH RH RH

UNF	P	Ød ₁	L ₁ js16	L ₂	L ₃	Ød ₂ h9	a h12	z	z	z	A8 ROUGHING ...0081A1MA0	A8 FINISHING ...0081A3MA0	A8 SET ...0081ASMA0
	[TPI]	[mm]	[mm]	[mm]	[mm]	[mm]	[mm]	[-]	[mm]	[mm]			
Nr.2	64	2,184	36	9	15	2,8	2,1	3	1,85		AN0264...	AN0264...	AN0264...
Nr.3	56	2,515	40	9	15	2,8	2,1	3	2,15		AN0356...	AN0356...	AN0356...
Nr.4	48	2,845	40	10	18	3,5	2,7	3	2,4		AN0448...	AN0448...	AN0448...
Nr.5	44	3,175	40	10	18	3,5	2,7	3	2,7		AN0544...	AN0544...	AN0544...
Nr.6	40	3,505	45	11	20	4	3	3	2,95		AN0640...	AN0640...	AN0640...
Nr.8	36	4,166	45	12	21	4,5	3,4	3	3,5		AN0836...	AN0836...	AN0836...
Nr.10	32	4,826	50	14	23	6	4,9	3	4,1		AN1032...	AN1032...	AN1032...
Nr.12	28	5,486	56	16	28	6	4,9	3	4,6		AN1228...	AN1228...	AN1228...
1/4"	28	6,35	56	16	28	6	4,9	3	5,5		ANA140...	ANA140...	ANA140...
5/16"	24	7,938	63	18	-	6	4,9	3	6,9		ANB516...	ANB516...	ANB516...
3/8"	24	9,525	63	18	-	7	5,5	3	8,5		ANC380...	ANC380...	ANC380...
7/16"	20	11,113	70	20	-	8	6,2	3	9,9		AND716...	AND716...	AND716...
1/2"	20	12,7	70	20	-	9	7	4	11,5		ANE120...	ANE120...	ANE120...
9/16"	18	14,288	70	22	-	11	9	4	12,9		ANF916...	ANF916...	ANF916...
5/8"	18	15,875	70	22	-	12	9	4	14,5		ANG580...	ANG580...	ANG580...
3/4"	16	19,05	80	22	-	14	11	4	17,5		ANH340...	ANH340...	ANH340...
7/8"	14	22,225	80	22	-	18	14,5	4	20,4		ANL780...	ANL780...	ANL780...
1"	12	25,4	90	22	-	18	14,5	4	23,25		ANM100...	ANM100...	ANM100...
1 1/8"	12	28,575	90	22	-	22	18	4	26,5		ANN118...	ANN118...	ANN118...
1 1/4"	12	31,75	90	22	-	22	18	4	29,5		ANP114...	ANP114...	ANP114...



A28 FC
BRIGHT

A28 FC
TiN

A28 FP
BRIGHT

A28 FP
TiN

A SERIES

DIN 2184-1
≤ Ø 1/4"

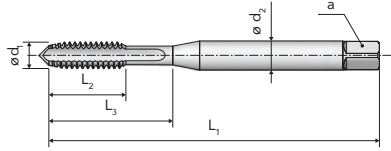

DIN 2184-1
≥ Ø 5/16"

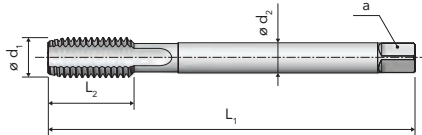

APPLICATION RANGE - CUTTING SPEED m/min

ISO	MG	A28 FC BRIGHT	A28 FC TiN	A28 FP BRIGHT	A28 FP TiN
P	P.1		● 20-25		● 20-25
	P.2	● 10-12	● 15-20	● 10-12	● 15-20
	P.3	● 8-10	● 12-15	● 8-10	● 12-15
K	K.2	● 8-10	● 12-15	● 8-10	● 12-15
N	N.1		● 20-25		● 20-25
	N.5		● 15-20		● 15-20



UNF	P	Ød ₁	L ₁ js 16	L ₂	L ₃	Ød ₂ h9	a h12	z		A28 FC BRIGHT ...0282A1MA0	A28 FC TiN ...0282A1MD0	A28 FP BRIGHT ...0282A2MA0	A28 FP TiN ...0282A2MD0
	[TPI]	[mm]	[mm]	[mm]	[mm]	[mm]	[mm]	[-]	[mm]				
Nr.2	64	2,184	45	9	13	2,8	2,1	3	1,85	AN0264...	AN0264...	AN0264...	AN0264...
Nr.3	56	2,515	50	9	15	2,8	2,1	3	2,15	AN0356...	AN0356...	AN0356...	AN0356...
Nr.4	48	2,845	56	10	18	3,5	2,7	3	2,4	AN0448...	AN0448...	AN0448...	AN0448...
Nr.5	44	3,175	56	10	18	3,5	2,7	3	2,7	AN0544...	AN0544...	AN0544...	AN0544...
Nr.6	40	3,505	56	11	20	4	3	3	2,95	AN0640...	AN0640...	AN0640...	AN0640...
Nr.8	36	4,166	63	12	21	4,5	3,4	3	3,5	AN0836...	AN0836...	AN0836...	AN0836...
Nr.10	32	4,826	70	14	24,5	6	4,9	3	4,1	AN1032...	AN1032...	AN1032...	AN1032...
Nr.12	28	5,486	80	16	26,5	6	4,9	3	4,6	AN1228...	AN1228...	AN1228...	AN1228...
1/4"	28	6,35	80	16	30	7	5,5	3	5,5	ANA140...	ANA40...	ANA140...	ANA140...
5/16"	24	7,938	90	18	-	6	4,9	3	6,9	ANB516...	ANB516...	ANB516...	ANB516...
3/8"	24	9,525	90	18	-	7	5,5	3	8,5	ANC380...	ANC380...	ANC380...	ANC380...
7/16"	20	11,113	100	20	-	8	6,2	3	9,9	AND716...	AND716...	AND716...	AND716...
1/2"	20	12,7	100	22	-	9	7	3	11,5	ANE120...	ANE120...	ANE120...	ANE120...
9/16"	18	14,288	100	22	-	11	9	3	12,9	ANF916...	ANF916...	ANF916...	ANF916...
5/8"	18	15,875	100	22	-	12	9	3	14,5	ANG580...	ANG580...	ANG580...	ANG580...
3/4"	16	19,05	110	25	-	14	11	4	17,5	ANH340...	ANH340...	ANH340...	ANH340...
7/8"	14	22,225	125	25	-	18	14,5	4	20,4	ANL780...	ANL780...	ANL780...	ANL780...
1"	12	25,4	140	28	-	18	14,5	4	23,25	ANM100...	ANM100...	ANM100...	ANM100...
11/8"	12	28,575	150	28	-	22	18	4	26,5	ANN118...		ANN118...	
11/4"	12	31,75	150	28	-	22	18	4	29,5	ANP114...		ANP114...	
13/8"	12	34,925	170	30	-	28	22	5	32,75	ANQ138...		ANQ138...	
11/2"	12	38,1	170	30	-	28	22	5	36	ANR112...		ANR112...	



A50
NITRIDED

A50
TiCN

DIN 2184-1
≤ Ø 1/4"

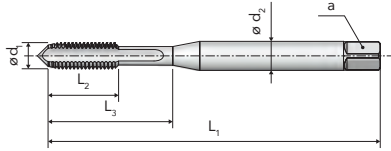

DIN 2184-1
≥ Ø 5/16"

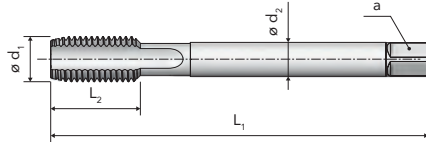

A
SERIES

APPLICATION RANGE - CUTTING SPEED m/min

ISO	MG	A50 NITRIDED	A50 TiCN		
K	K.1	• 15-20	• 40-45		
N	N.4	• 15-20	• 40-45		
	N.7	• 15-20	• 40-45		
	N.9-10	• 20-25	• 45-50		



UNF	P	Ød ₁	L ₁ js 16	L ₂	L ₃	Ød ₂ h9	a h12	z		A50 NITRIDED ...0502A1MCO	A50 TiCN ...0502A1MEO
	[TPI]	[mm]	[mm]	[mm]	[mm]	[mm]	[mm]	[-]	[mm]		
Nr.8	36	4,166	63	12	21	4,5	3,4	3	3,5	AN0836...	AN0836...
Nr.10	32	4,826	70	14	24,5	6	4,9	3	4,1	AN1032...	AN1032...
Nr.12	28	5,486	80	16	26,5	6	4,9	3	4,6	AN1228...	AN1228...
1/4"	28	6,35	80	16	30	7	5,5	3	5,5	ANA140...	ANA140...
5/16"	24	7,938	90	18	-	6	4,9	4	6,9	ANB516...	ANB516...
3/8"	24	9,525	90	18	-	7	5,5	4	8,5	ANC380...	ANC380...
7/16"	20	11,113	100	20	-	8	6,2	4	9,9	AND716...	AND716...
1/2"	20	12,7	100	22	-	9	7	4	11,5	ANE120...	ANE120...
9/16"	18	14,288	100	22	-	11	9	4	12,9	ANF916...	ANF916...
5/8"	18	15,875	100	22	-	12	9	4	14,5	ANG580...	ANG580...
3/4"	16	19,05	110	25	-	14	11	4	17,5	ANH340...	ANH340...
7/8"	14	22,225	125	25	-	18	14,5	4	20,4	ANL780...	ANL780...
1"	12	25,4	140	28	-	18	14,5	5	23,25	ANM100...	ANM100...
1 1/8"	12	28,575	150	28	-	22	18	5	26,5	ANN118...	
1 1/4"	12	31,75	150	28	-	22	18	5	29,5	ANP114...	
1 3/8"	12	34,925	170	30	-	28	22	5	32,75	ANQ138...	
1 1/2"	12	38,1	170	30	-	28	22	5	36	ANR112...	



A20 S
BRIGHT

A20 S
TiN

A20 S
TiCN

A20 S 3B
BRIGHT

A SERIES

DIN 2184-1
≤ Ø 1/4"

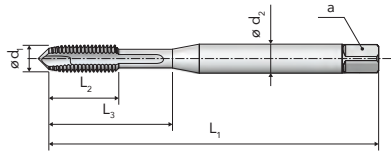

DIN 2184-1
≥ Ø 5/16"

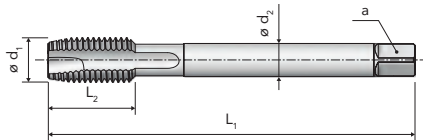

APPLICATION RANGE - CUTTING SPEED m/min

ISO	MG	A20 S BRIGHT	A20 S TiN	A20 S TiCN	A20 S 3B BRIGHT
P	P.2	● 20-25	● 30-35	● 30-35	● 20-25
	P.3	● 15-20	● 25-30	● 25-30	● 15-20
	P.4	● 12-15	● 20-25	● 20-25	● 12-15
	P.5		● 10-15	● 10-15	
M	M.1		● 8-10	● 8-10	
	K.2	● 15-20	● 25-30	● 25-30	● 15-20
N	N.2-3	● 20-25	● 30-35	● 30-35	● 20-25
	N.6	● 15-18	● 25-30	● 25-30	● 15-18



UNF	P	Ød ₁	L ₁ js 16	L ₂	L ₃	Ød ₂ h9	a h12	z		A20 S BRIGHT ...0202B2MA0	A20 S TiN ...0202B2M00	A20 S TiCN ...0202B2M00	A20 S 3B BRIGHT ...0202B2NA0
Nr.2	64	2,184	45	8	13	2,8	2,1	2	1,85	AN0264...	AN0264...	AN0264...	
Nr.3	56	2,515	50	9	15	2,8	2,1	3	2,15	AN0356...	AN0356...	AN0356...	
Nr.4	48	2,845	56	10	18	3,5	2,7	3	2,4	AN0448...	AN0448...	AN0448...	
Nr.5	44	3,175	56	10	18	3,5	2,7	3	2,7	AN0544...	AN0544...	AN0544...	
Nr.6	40	3,505	56	11	20	4	3	3	2,95	AN0640...	AN0640...	AN0640...	AN0640...
Nr.8	36	4,166	63	12	21	4,5	3,4	3	3,5	AN0836...	AN0836...	AN0836...	AN0836...
Nr.10	32	4,826	70	14	24,5	6	4,9	3	4,1	AN1032...	AN1032...	AN1032...	AN1032...
Nr.12	28	5,486	80	16	26,5	6	4,9	3	4,6	AN1228...	AN1228...	AN1228...	AN1228...
1/4"	28	6,35	80	16	30	7	5,5	3	5,5	ANA140...	ANA140...	ANA140...	ANA140...
5/16"	24	7,938	90	18	-	6	4,9	3	6,9	ANB516...	ANB516...	ANB516...	ANB516...
3/8"	24	9,525	90	18	-	7	5,5	3	8,5	ANC380...	ANC380...	ANC380...	ANC380...
7/16"	20	11,113	100	20	-	8	6,2	3	9,9	AND716...	AND716...	AND716...	AND716...
1/2"	20	12,7	100	22	-	9	7	4	11,5	ANE120...	ANE120...	ANE120...	ANE120...
9/16"	18	14,288	100	22	-	11	9	4	12,9	ANF916...	ANF916...	ANF916...	ANF916...
5/8"	18	15,875	100	22	-	12	9	4	14,5	ANG580...	ANG580...	ANG580...	ANG580...
3/4"	16	19,05	110	25	-	14	11	4	17,5	ANH340...	ANH340...	ANH340...	ANH340...
7/8"	14	22,225	125	25	-	18	14,5	4	20,4	ANL780...	ANL780...	ANL780...	ANL780...
1"	12	25,4	140	28	-	18	14,5	4	23,25	ANM100...	ANM100...	ANM100...	
1 1/4"	12	31,75	150	28	-	22	18	4	29,5	ANP114...			
1 1/2"	12	38,1	170	30	-	28	22	5	36	ANR112...			

MACHINE TAPS for through holes
Straight flutes with spiral point / for stainless steel



A20 S
TiX2

DIN 2184-1
≤ Ø 1/4"

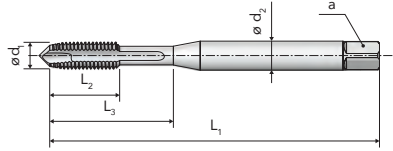

DIN 2184-1
≥ Ø 5/16"

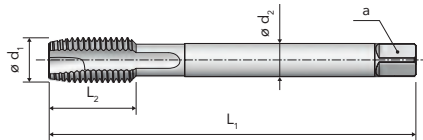

A SERIES

APPLICATION RANGE - CUTTING SPEED m/min

ISO	MG	A20 S TiX2			
P	P.7	• 10-15			
M	M.1	• 10-15			



UNF	P	Ød ₁	L ₁ js16	L ₂	L ₃	Ød ₂ h9	a h12	z	z	z	A20 S TiX2 ...0202B2MLO
	[TPI]	[mm]	[mm]	[mm]	[mm]	[mm]	[mm]	[-]	[mm]	[mm]	
Nr.6	40	3,505	56	11	20	4	3	3	2,95		AN0640...
Nr.8	36	4,166	63	12	21	4,5	3,4	3	3,5		AN0836...
Nr.10	32	4,826	70	14	24,5	6	4,9	3	4,1		AN1032...
Nr.12	28	5,486	80	16	26,5	6	4,9	3	4,6		AN1228...
1/4"	28	6,35	80	16	30	7	5,5	3	5,5		ANA140...
5/16"	24	7,938	90	18	-	6	4,9	3	6,9		ANB516...
3/8"	24	9,525	90	18	-	7	5,5	3	8,5		ANC380...
7/16"	20	11,113	100	20	-	8	6,2	3	9,9		AND716...
1/2"	20	12,7	100	22	-	9	7	4	11,5		ANE120...
9/16"	18	14,288	100	22	-	11	9	4	12,9		ANF916...
5/8"	18	15,875	100	22	-	12	9	4	14,5		ANG580...
3/4"	16	19,05	110	25	-	14	11	4	17,5		ANH340...
7/8"	14	22,225	125	25	-	18	14,5	4	20,4		ANL780...
1"	12	25,4	140	28	-	18	14,5	4	23,25		ANM100...



A34
BRIGHT

A34
TiN

A34 3B
BRIGHT

A SERIES

DIN 2184-1
≤ Ø 1/4"

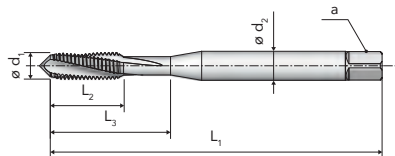

DIN 2184-1
≥ Ø 5/16"

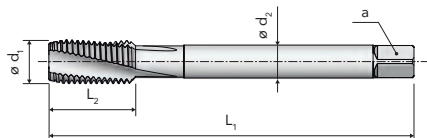

APPLICATION RANGE - CUTTING SPEED m/min

ISO	MG	A34 BRIGHT	A34 TiN	A34 3B BRIGHT
P	P.1	● 18-20	● 30-35	● 18-20
	P.2	● 15-18	● 25-30	● 15-18
	P.3	● 12-15	● 20-25	● 12-15
	P.4	● 10-12	● 15-20	● 10-12
	P.5		● 5-10	
K	K.2	● 12-15	● 20-25	● 12-15
N	N.1	● 18-20		● 18-20
	N.2-3	● 15-18	● 25-30	● 15-18
	N.5	● 15-18		● 15-18
	N.6	● 12-15	● 20-25	● 12-15



UNF	P	Ød ₁	L ₁ js 16	L ₂	L ₃	Ød ₂ h9	a h12	z		A34 BRIGHT ...0342A1MA0	A34 TiN ...0342A1MD0	A34 3B BRIGHT ...0342A1NA0
Nr.2	64	2,184	45	8	13	2,8	2,1	3	1,85	AN0264...	AN0264...	
Nr.3	56	2,515	50	9	15	2,8	2,1	3	2,15	AN0356...	AN0356...	
Nr.4	48	2,845	56	10	18	3,5	2,7	3	2,4	AN0448...	AN0448...	
Nr.5	44	3,175	56	10	18	3,5	2,7	3	2,7	AN0544...	AN0544...	
Nr.6	40	3,505	56	11	20	4	3	3	2,95	AN0640...	AN0640...	AN0640...
Nr.8	36	4,166	63	12	21	4,5	3,4	3	3,5	AN0836...	AN0836...	AN0836...
Nr.10	32	4,826	70	14	24,5	6	4,9	3	4,1	AN1032...	AN1032...	AN1032...
Nr.12	28	5,486	80	16	26,5	6	4,9	3	4,6	AN1228...	AN1228...	AN1228...
1/4"	28	6,35	80	16	30	7	5,5	3	5,5	ANA140...	ANA140...	ANA140...
5/16"	24	7,938	90	18	-	6	4,9	3	6,9	ANB516...	ANB516...	ANB516...
3/8"	24	9,525	90	18	-	7	5,5	3	8,5	ANC380...	ANC380...	ANC380...
7/16"	20	11,113	100	20	-	8	6,2	3	9,9	AND716...	AND716...	AND716...
1/2"	20	12,7	100	22	-	9	7	3	11,5	ANE120...	ANE120...	ANE120...
9/16"	18	14,288	100	22	-	11	9	3	12,9	ANF916...	ANF916...	ANF916...
5/8"	18	15,875	100	22	-	12	9	3	14,5	ANG580...	ANG580...	ANG580...
3/4"	16	19,05	110	25	-	14	11	4	17,5	ANH340...	ANH340...	ANH340...
7/8"	14	22,225	125	25	-	18	14,5	4	20,4	ANL780...	ANL780...	
1"	12	25,4	140	28	-	18	14,5	4	23,25	ANM100...	ANM100...	
11/8"	12	28,575	150	28	-	22	18	4	26,5	ANN118...		
11/4"	12	31,75	150	28	-	22	18	4	29,5	ANP114...		
13/8"	12	34,925	170	30	-	28	22	5	32,75	ANQ138...		
11/2"	12	38,1	170	30	-	28	22	5	36	ANR112...		



A61S
BRIGHT

A61S
TiN

A61S
TiCN

A61S
TiX2

DIN 2184-1
≤ Ø 1/4"

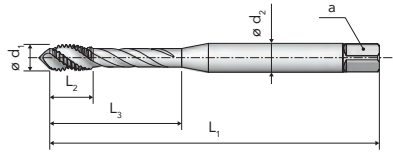

DIN 2184-1
≥ Ø 5/16"

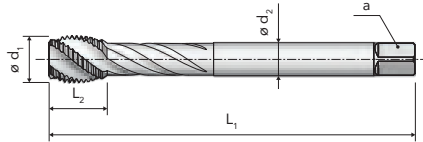

A SERIES

APPLICATION RANGE - CUTTING SPEED m/min

ISO	MG	A61S BRIGHT	A61S TiN	A61S TiCN	A61S TiX2
P	P.2	● 15-20	● 25-30	● 25-30	
	P.3	● 12-15	● 20-25	● 20-25	
	P.4	● 10-12	● 15-20	● 15-20	
	P.5		● 5-10	● 5-10	
	P.7		● 6-8	● 6-8	● 6-8
M	M.1		● 6-8	● 6-8	● 6-8
K	K.2	● 12-15	● 20-25	● 20-25	
N	N.3	● 15-18	● 25-30	● 25-30	
	N.6	● 15-18	● 25-30	● 25-30	



UNF	P	Ød ₁	L ₁	L ₂	L ₃	Ød ₂	a	z	z	z	A61S BRIGHT	A61S TiN	A61S TiCN	A61S TiX2
	[TPI]	[mm]	[mm]	[mm]	[mm]	[mm]	[mm]	[-]	[mm]	[mm]	...0612B1MA0	...0612B1MD0	...0612B1ME0	...0612B1ML0
Nr.2	64	2,184	45	5,5	13	2,8	2,1	3	1,85		AN0264...	AN0264...	AN0264...	
Nr.3	56	2,515	50	6	18	2,8	2,1	3	2,15		AN0356...	AN0356...	AN0356...	
Nr.4	48	2,845	56	6	18	3,5	2,7	3	2,4		AN0448...	AN0448...	AN0448...	
Nr.5	44	3,175	56	6	18	3,5	2,7	3	2,7		AN0544...	AN0544...	AN0544...	
Nr.6	40	3,505	56	6,5	22	4	3	3	2,95		AN0640...	AN0640...	AN0640...	AN0640...
Nr.8	36	4,166	63	7	26,5	4,5	3,4	3	3,5		AN0836...	AN0836...	AN0836...	AN0836...
Nr.10	32	4,826	70	8	29	6	4,9	3	4,1		AN1032...	AN1032...	AN1032...	AN1032...
Nr.12	28	5,486	80	9	29,5	6	4,9	3	4,6		AN1228...	AN1228...	AN1228...	AN1228...
1/4"	28	6,35	80	10	32	7	5,5	3	5,5		ANA140...	ANA140...	ANA140...	ANA140...
5/16"	24	7,938	90	11	-	6	4,9	3	6,9		ANB516...	ANB516...	ANB516...	ANB516...
3/8"	24	9,525	90	12	-	7	5,5	3	8,5		ANC380...	ANC380...	ANC380...	ANC380...
7/16"	20	11,113	100	13,5	-	8	6,2	3	9,9		AND716...	AND716...	AND716...	AND716...
1/2"	20	12,7	100	14,5	-	9	7	4	11,5		ANE120...	ANE120...	ANE120...	ANE120...
9/16"	18	14,288	100	15,5	-	11	9	4	12,9		ANF916...	ANF916...	ANF916...	ANF916...
5/8"	18	15,875	100	16	-	12	9	4	14,5		ANG580...	ANG580...	ANG580...	ANG580...
3/4"	16	19,05	110	18	-	14	11	4	17,5		ANH340...	ANH340...	ANH340...	ANH340...
7/8"	14	22,225	125	23,5	-	18	14,5	4	20,4		ANL780...	ANL780...	ANL780...	ANL780...
1"	12	25,4	140	26	-	18	14,5	4	23,25		ANM100...	ANM100...	ANM100...	ANM100...
1 1/4"	12	31,75	150	26	-	22	18	5	29,5		ANP114...			
1 1/2"	12	38,1	170	29	-	28	22	5	36		ANR112...			





A66
BRIGHT

A SERIES

DIN 2184-1
≤ Ø 1/4"

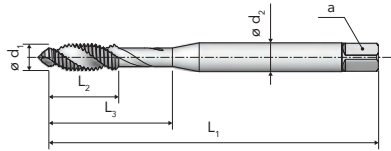

DIN 2184-1
≥ Ø 5/16"

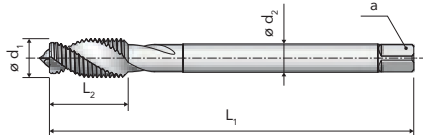

APPLICATION RANGE - CUTTING SPEED m/min

ISO	MG	A66 BRIGHT			
N	N.1-2	• 12-15			
	N.5-6	• 10-12			
S	S.1	• 6-8			
	S.3	• 6-8			



UNF	P [TPI]	Ød ₁ [mm]	L ₁ js 16 [mm]	L ₂ [mm]	L ₃ [mm]	Ød ₂ h9 [mm]	a h12 [mm]	Z [-]	Ø [mm]	A66 BRIGHT ...0662A1MA0
Nr.2	64	2,184	45	8	13	2,8	2,1	2	1,85	AN0264...
Nr.3	56	2,515	50	9	15	2,8	2,1	2	2,15	AN0356...
Nr.4	48	2,845	56	10	18	3,5	2,7	2	2,4	AN0448...
Nr.5	44	3,175	56	10	18	3,5	2,7	2	2,7	AN0544...
Nr.6	40	3,505	56	11	20	4	3	2	2,95	AN0640...
Nr.8	36	4,166	63	12	21	4,5	3,4	2	3,5	AN0836...
Nr.10	32	4,826	70	14	24,5	6	4,9	2	4,1	AN1032...
Nr.12	28	5,486	80	16	26,5	6	4,9	2	4,6	AN1228...
1/4"	28	6,35	80	16	30	7	5,5	2	5,5	ANA140...
5/16"	24	7,938	90	18	-	6	4,9	2	6,9	ANB516...
3/8"	24	9,525	90	18	-	7	5,5	2	8,5	ANC380...



A119
BRIGHT

A119
TiN

NORM VERGNANO

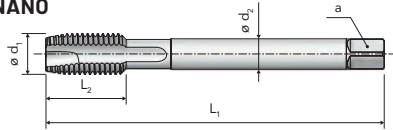

A SERIES

APPLICATION RANGE - CUTTING SPEED m/min

ISO	MG	A119 BRIGHT	A119 TiN
P	P.2	• 20-25	• 30-35
	P.3	• 15-20	• 25-30
	P.4	• 12-15	• 20-25
	P.5		• 10-15
	P.7		• 8-10
M	M.1		• 8-10
K	K.2	• 15-20	• 25-30
N	N.2-3	• 20-25	• 30-35
	N.6	• 15-18	• 25-30



8-UN	P	Ød ₁	L ₁ js16	L ₂	L ₃	Ød ₂ h9	a h12	z	z	A119 BRIGHT ...1192A2MA0	A119 TiN ...1192A2MDO
	[TPI]	[mm]	[mm]	[mm]	[mm]	[mm]	[mm]	[-]	[mm]		
11/8"	8	28,575	180	40	-	22	18	4	25,4	APN118...	APN118...
11/4"	8	31,75	180	40	-	25	20	4	28,6	APP114...	APP114...
13/8"	8	34,925	200	50	-	28	22	4	31,8	APQ138...	APQ138...
11/2"	8	38,1	200	50	-	32	24	4	35	APR112...	APR112...
15/8"	8	41,275	200	50	-	32	24	5	38,1	APS158...	APS158...
13/4"	8	44,45	200	50	-	36	29	5	41,3	APT134...	APT134...
17/8"	8	47,625	225	60	-	36	29	5	44,5	APU178...	APU178...
2"	8	50,8	225	60	-	40	32	5	47,7	APV200...	APV200...



A160
BRIGHT

A160
TiN

A SERIES

NORM VERGNANO

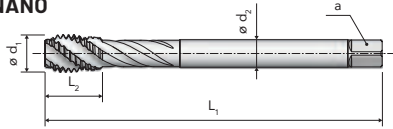

APPLICATION RANGE - CUTTING SPEED m/min

ISO	MG	A160 BRIGHT	A160 TiN
P	P.2	• 15-20	• 25-30
	P.3	• 12-15	• 20-25
	P.4	• 10-12	• 15-20
	P.5		• 5-10
	P.7		• 6-8
M	M.1		• 6-8
K	K.2	• 12-15	• 20-25
N	N.3	• 15-18	• 25-30
	N.6	• 15-18	• 25-30



8-UN	P	Ød ₁	L ₁ js 16	L ₂	L ₃	Ød ₂ h9	a h12	z		A160 BRIGHT ...1602A1MA0	A160 TiN ...1602A1MDO
	[TPI]	[mm]	[mm]	[mm]	[mm]	[mm]	[mm]	[-]	[mm]		
11/8"	8	28,575	180	40	-	22	18	4	25,4	APN118...	APN118...
11/4"	8	31,75	180	41,5	-	25	20	4	28,6	APP114...	APP114...
13/8"	8	34,925	200	50	-	28	22	4	31,1	APQ138...	APQ138...
11/2"	8	38,1	200	50	-	32	24	5	35	APR112...	APR112...
15/8"	8	41,275	200	52	-	32	24	5	38,1	APS158...	APS158...
13/4"	8	44,45	200	52	-	36	29	5	41,3	APT134...	APT134...
17/8"	8	47,625	225	53,5	-	36	29	5	44,5	APU178...	APU178...
2"	8	50,8	225	61,5	-	40	32	5	47,7	APV200...	APV200...



A5
ROUGHING

A5
FINISHING

A5
SET

DIN 5157

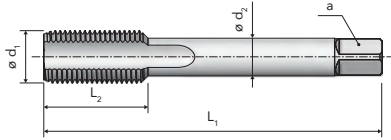

A SERIES

APPLICATION RANGE - CUTTING SPEED m/min

ISO	MG	A5 ROUGHING	A5 FINISHING	A5 SET
P	P.1-4	•	•	•
	P.7	•	•	•
K	K.2	•	•	•
N	N.1-3	•	•	•
	N.5-7	•	•	•

—	ISO 5969	ISO 5969
A (5-6)	C (2-3)	C (2-3)
2,5xD	2,5xD	2,5xD
RH	RH	RH

G	P	$\varnothing d_1$	L_1 js16	L_2	L_3	$\varnothing d_2$ h9	a h12	z		A5 ROUGHING ...0051A1LA0	A5 FINISHING ...0051A3LA0	A5 SET ...0051ASLA0
1/8"	28	9,728	63	18	-	7	5,5	3	8,8	AGA180...	AGA180...	AGA180...
1/4"	19	13,157	70	20	-	11	9	4	11,8	AGB140...	AGB140...	AGB140...
3/8"	19	16,662	70	20	-	12	9	4	15,25	AGC380...	AGC380...	AGC380...
1/2"	14	20,955	80	22	-	16	12	4	19	AGD120...	AGD120...	AGD120...
5/8"	14	22,911	80	22	-	18	14,5	4	21	AGE580...	AGE580...	AGE580...
3/4"	14	26,441	90	22	-	20	16	4	24,5	AGF340...	AGF340...	AGF340...
7/8"	14	30,201	90	22	-	22	18	4	28,25	AGG780...	AGG780...	AGG780...
1"	11	33,249	100	25	-	25	20	4	30,75	AGH100...	AGH100...	AGH100...
1 1/8"	11	37,897	125	32	-	28	22	5	35,5	AGL118...	AGL118...	AGL118...
1 1/4"	11	41,91	125	32	-	32	24	5	39,5	AGM114...	AGM114...	AGM114...
1 1/2"	11	47,803	140	32	-	36	29	6	45,25	AGP112...	AGP112...	AGP112...
1 3/4"	11	53,746	140	36	-	40	32	6	51	AGQ134...	AGQ134...	AGQ134...
2"	11	59,614	160	36	-	45	35	6	57	AGR200...	AGR200...	AGR200...



A26 FC
BRIGHT

A26 FP
BRIGHT

A SERIES

DIN 5156

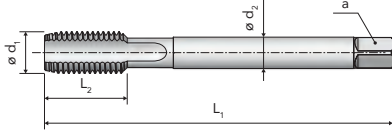

APPLICATION RANGE - CUTTING SPEED m/min

ISO	MG	A26 FC BRIGHT	A26 FP BRIGHT
P	P.2	● 10-12	● 10-12
	P.3	● 8-10	● 8-10
K	K.2	● 8-10	● 8-10



G	P [TPI]	$\varnothing d_1$ [mm]	L_1 js 16 [mm]	L_2 [mm]	L_3 [mm]	$\varnothing d_2$ h9 [mm]	a h12 [mm]	z [-]		A26 FC BRIGHT ...0262A1LA0	A26 FP BRIGHT ...0262A2LA0
1/8"	28	9,728	90	18	-	7	5,5	3	8,8	AGA180...	AGA180...
1/4"	19	13,157	100	22	-	11	9	3	11,8	AGB140...	AGB140...
3/8"	19	16,662	100	22	-	12	9	3	15,25	AGC380...	AGC380...
1/2"	14	20,955	125	25	-	16	12	4	19	AGD120...	AGD120...
5/8"	14	22,911	125	25	-	18	14,5	4	21	AGE580...	AGE580...
3/4"	14	26,441	140	28	-	20	16	4	24,5	AGF340...	AGF340...
7/8"	14	30,201	150	28	-	22	18	4	28,25	AGG780...	AGG780...
1"	11	33,249	160	30	-	25	20	4	30,75	AGH100...	AGH100...
1 1/8"	11	37,897	170	30	-	28	22	5	35,5	AGL118...	AGL118...
1 1/4"	11	41,91	170	30	-	32	24	5	39,5	AGM114...	AGM114...
1 1/2"	11	47,803	190	32	-	36	29	6	45,25	AGP112...	AGP112...
1 3/4"	11	53,746	190	32	-	40	32	6	51	AGQ134...	AGQ134...
2"	11	59,614	220	40	-	45	35	6	57	AGR200...	AGR200...
2 1/2"	11	75,184	250	50	-	45	35	8	72,8	AGT212...	AGT212...



A48
NITRIDED

A48
TiCN

DIN 5156

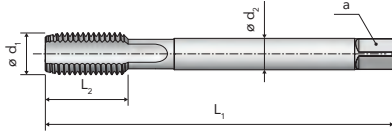

A SERIES

APPLICATION RANGE - CUTTING SPEED m/min

ISO	MG	A48 NITRIDED	A48 TiCN
K	K.1	● 15-20	● 40-45
N	N.4	● 15-20	● 40-45
	N.7	● 15-20	● 40-45
	N.9-10	● 20-25	● 45-50



G	P	$\varnothing d_1$	L_1 js16	L_2	L_3	$\varnothing d_2$ h9	a h12	z		A48 NITRIDED ...0482A1LCO	A48 TiCN ...0482A1LEO
1/8"	28	9,728	90	18	-	7	5,5	4	8,8	AGA180...	AGA180...
1/4"	19	13,157	100	22	-	11	9	4	11,8	AGB140...	AGB140...
3/8"	19	16,662	100	22	-	12	9	4	15,25	AGC380...	AGC380...
1/2"	14	20,955	125	25	-	16	12	4	19	AGD120...	AGD120...
5/8"	14	22,911	125	25	-	18	14,5	4	21	AGE580...	AGE580...
3/4"	14	26,441	140	28	-	20	16	5	24,5	AGF340...	AGF340...
7/8"	14	30,201	150	28	-	22	18	5	28,25	AGG780...	AGG780...
1"	11	33,249	160	30	-	25	20	5	30,75	AGH100...	AGH100...
1 1/8"	11	37,897	170	30	-	28	22	6	35,5	AGL118...	
1 1/4"	11	41,91	170	30	-	32	24	6	39,5	AGM114...	
1 1/2"	11	47,803	190	32	-	36	29	6	45,25	AGP112...	



A18 S
BRIGHT

A18 S
VAP

A18 S
TiCN

A18 S
TiX2

A SERIES

DIN 5156

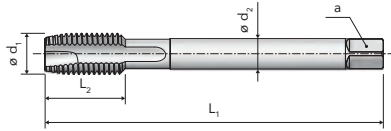

APPLICATION RANGE - CUTTING SPEED m/min

ISO	MG	A18 S BRIGHT	A18 S VAP	A18 S TiCN	A18 S TiX2
P	P.2	• 20-25	• 20-25	• 30-35	
	P.3	• 15-20	• 15-20	• 25-30	
	P.4	• 12-15	• 12-15	• 20-25	
	P.5			• 10-15	
	P.7			• 8-10	• 10-12
M	M.1			• 8-10	• 10-12
K	K.2	• 15-20	• 15-20	• 25-30	
N	N.2-3	• 20-25	• 20-25	• 30-35	
	N.6	• 15-18	• 15-18	• 25-30	



G	P	$\varnothing d_1$	L_1 js16	L_2	L_3	$\varnothing d_2$ h9	a h12	z		A18 S BRIGHT ...0182B2LA0	A18 S VAP ...0182B2LB0	A18 S TiCN ...0182B2LE0	A18 S TiX2 ...0182B2LL0
1/8"	28	9,728	90	18	-	7	5,5	4	8,8	AGA180...	AGA180...	AGA180...	AGA180...
1/4"	19	13,157	100	22	-	11	9	4	11,8	AGB140...	AGB140...	AGB140...	AGB140...
3/8"	19	16,662	100	22	-	12	9	4	15,25	AGC380...	AGC380...	AGC380...	AGC380...
1/2"	14	20,955	125	25	-	16	12	4	19	AGD120...	AGD120...	AGD120...	AGD120...
5/8"	14	22,911	125	25	-	18	14,5	4	21	AGE580...	AGE580...	AGE580...	AGE580...
3/4"	14	26,441	140	28	-	20	16	4	24,5	AGF340...	AGF340...	AGF340...	AGF340...
7/8"	14	30,201	150	28	-	22	18	4	28,25	AGG780...	AGG780...	AGG780...	AGG780...
1"	11	33,249	160	30	-	25	20	4	30,75	AGH100...	AGH100...	AGH100...	AGH100...
1 1/8"	11	37,897	170	30	-	28	22	5	35,5	AGL118...			
1 1/4"	11	41,91	170	30	-	32	24	5	39,5	AGM114...			
1 1/2"	11	47,803	190	32	-	36	29	5	45,25	AGP112...			



A32
BRIGHT

A32
TiN

DIN 5156

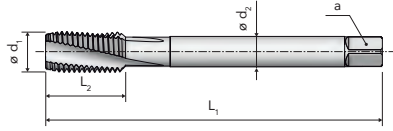

A SERIES

APPLICATION RANGE - CUTTING SPEED m/min

ISO	MG	A32 BRIGHT	A32 TiN
P	P.1	• 18-20	• 30-35
	P.2	• 15-18	• 25-30
	P.3	• 12-15	• 20-25
	P.4	• 10-12	• 15-20
	P.5		• 5-10
K	K.2	• 12-15	• 20-25
N	N.1	• 18-20	
	N.2-3	• 15-18	• 25-30
	N.5	• 15-18	
	N.6	• 12-15	• 20-25



G	P	$\varnothing d_1$	L_1 js16	L_2	L_3	$\varnothing d_2$ h9	a h12	z		A32 BRIGHT ...0322A1LA0	A32 TiN ...0322A1LDO
1/8"	28	9,728	90	18	-	7	5,5	3	8,8	AGA180...	AGA180...
1/4"	19	13,157	100	22	-	11	9	3	11,8	AGB140...	AGB140...
3/8"	19	16,662	100	22	-	12	9	3	15,25	AGC380...	AGC380...
1/2"	14	20,955	125	25	-	16	12	4	19	AGD120...	AGD120...
5/8"	14	22,911	125	25	-	18	14,5	4	21	AGE580...	AGE580...
3/4"	14	26,441	140	28	-	20	16	4	24,5	AGF340...	AGF340...
7/8"	14	30,201	150	28	-	22	18	4	28,25	AGG780...	AGG780...
1"	11	33,249	160	30	-	25	20	4	30,75	AGH100...	AGH100...
1 1/8"	11	37,897	170	30	-	28	22	5	35,5	AGL118...	
1 1/4"	11	41,91	170	30	-	32	24	5	39,5	AGM114...	
1 1/2"	11	47,803	190	32	-	36	29	6	45,25	AGP112...	
1 3/4"	11	53,746	190	32	-	40	32	6	51	AGQ134...	
2"	11	59,614	220	40	-	45	35	6	57	AGR200...	
2 1/2"	11	75,184	250	50	-	45	35	8	72,8	AGT212...	



A59 S
BRIGHT

A59 S
VAP

A59 S
TiN

A59 S
TiCN

A SERIES

DIN 5156

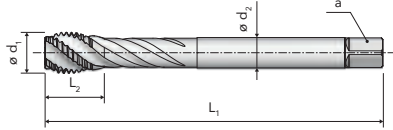

APPLICATION RANGE - CUTTING SPEED m/min

ISO	MG	A59 S BRIGHT	A59 S VAP	A59 S TiN	A59 S TiCN
P	P.2	● 15-20	● 15-20	● 25-30	● 25-30
	P.3	● 12-15	● 12-15	● 20-25	● 20-25
	P.4	● 10-12	● 10-12	● 15-20	● 15-20
	P.5			● 5-10	● 5-10
	P.7			● 6-8	● 6-8
M	M.1			● 6-8	● 6-8
K	K.2	● 12-15	● 12-15	● 20-25	● 20-25
N	N.3	● 15-18	● 15-18	● 25-30	● 25-30
	N.6	● 15-18	● 15-18	● 25-30	● 25-30



G	P	$\varnothing d_1$	L_1 js16	L_2	L_3	$\varnothing d_2$ h9	a h12	z		A59 S BRIGHT ...0592B1LA0	A59 S VAP ...0592B1LB0	A59 S TiN ...0592B1LD0	A59 S TiCN ...0592B1LE0
	[TPI]	[mm]	[mm]	[mm]	[mm]	[mm]	[mm]	[-]	[mm]				
1/8"	28	9,728	90	17	-	7	5,5	3	8,8	AGA180...	AGA180...	AGA180...	AGA180...
1/4"	19	13,157	100	23	-	11	9	4	11,8	AGB140...	AGB140...	AGB140...	AGB140...
3/8"	19	16,662	100	23	-	12	9	4	15,25	AGC380...	AGC380...	AGC380...	AGC380...
1/2"	14	20,955	125	29	-	16	12	5	19	AGD120...	AGD120...	AGD120...	AGD120...
5/8"	14	22,911	125	29	-	18	14,5	5	21	AGE580...	AGE580...	AGE580...	AGE580...
3/4"	14	26,441	140	29	-	20	16	5	24,5	AGF340...	AGF340...	AGF340...	AGF340...
7/8"	14	30,201	150	32	-	22	18	5	28,25	AGG780...	AGG780...	AGG780...	AGG780...
1"	11	33,249	160	34,5	-	25	20	5	30,75	AGH100...	AGH100...	AGH100...	AGH100...
1 1/8"	11	37,897	170	34,5	-	28	22	5	35,5	AGL118...	AGL118...		
1 1/4"	11	41,91	170	34,5	-	32	24	5	39,5	AGM114...	AGM114...		
1 1/2"	11	47,803	190	37,5	-	36	29	6	45,25	AGP112...	AGP112...		



A59 S
TiX2

DIN 5156

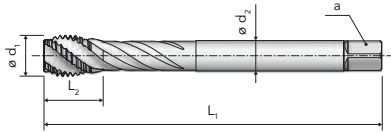

A SERIES

APPLICATION RANGE - CUTTING SPEED m/min

ISO	MG	A59 S TiX2			
P	P.7	• 6-8			
M	M.1	• 6-8			



G	P	Ød ₁	L ₁ js16	L ₂	L ₃	Ød ₂ h9	a h12	z	z	Ø	A59 S TiX2 ...0592B1LLO
	[TPI]	[mm]	[mm]	[mm]	[mm]	[mm]	[mm]	[-]	[mm]	[mm]	
1/8"	28	9,728	90	17	-	7	5,5	3	8,8	8,8	AGA180...
1/4"	19	13,157	100	23	-	11	9	4	11,8	11,8	AGB140...
3/8"	19	16,662	100	23	-	12	9	4	15,25	15,25	AGC380...
1/2"	14	20,955	125	29	-	16	12	5	19	19	AGD120...
5/8"	14	22,911	125	29	-	18	14,5	5	21	21	AGE580...
3/4"	14	26,441	140	29	-	20	16	5	24,5	24,5	AGF340...
7/8"	14	30,201	150	32	-	22	18	5	28,25	28,25	AGG780...
1"	11	33,249	160	34,5	-	25	20	5	30,75	30,75	AGH100...



A82 N
TiN

A SERIES

DIN 2189

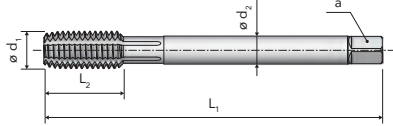

APPLICATION RANGE - CUTTING SPEED m/min

ISO	MG	A82 N TiN			
P	P.1-2	• 20-25			
	P.3	• 15-20			
N	N.1-2	• 20-25			
	N.3	• 15-20			
	N.5-6	• 20-25			



G	P	$\varnothing d_1$	L_1 js 16	L_2	L_3	$\varnothing d_2$ h9	a h12	z		A82 N TiN			
	[TPI]	[mm]	[mm]	[mm]	[mm]	[mm]	[mm]	[-]	[mm]	...0822G1AD0			
1/8"	28	9,728	90	18	-	7	5,5	6	9,25	AGA180...			
1/4"	19	13,157	100	22	-	11	9	6	12,5	AGB140...			
3/8"	19	16,662	100	22	-	12	9	6	16	AGC380...			
1/2"	14	20,955	125	25	-	16	12	6	20	AGD120...			
3/4"	14	26,441	140	28	-	20	16	6	25,5	AGF340...			
1"	11	33,249	160	30	-	25	20	8	32	AGH100...			



A159 S
BRIGHT

A159 S
TiN

DIN 5156

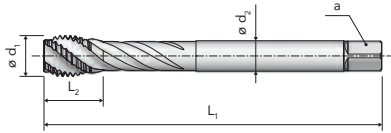

A
SERIES

APPLICATION RANGE - CUTTING SPEED m/min

ISO	MG	A159 S BRIGHT	A159 S TiN
P	P.2	• 15-20	• 25-30
	P.3	• 12-15	• 20-25
	P.4	• 10-12	• 15-20
	P.5		• 5-10
	P.7		• 6-8
M	M.1		• 6-8
K	K.2	• 12-15	• 20-25
N	N.3	• 15-18	• 25-30
	N.6	• 15-18	• 25-30



Rp	P	$\varnothing d_1$	L_1 js16	L_2	L_3	$\varnothing d_2$ h9	a h12	z		A159 S BRIGHT ...1592B1LA0	A159 S TiN ...1592B1LDO
1/8"	28	9,728	90	17	-	7	5,5	3	8,6	AGA180...	AGA180...
1/4"	19	13,157	100	23	-	11	9	4	11,5	AGB140...	AGB140...
3/8"	19	16,662	100	23	-	12	9	4	15	AGC380...	AGC380...
1/2"	14	20,955	125	29	-	16	12	5	18,5	AGD120...	AGD120...
3/4"	14	26,441	140	29	-	20	16	5	24	AGF340...	AGF340...



A6
BRIGHT

A SERIES

NORM VERGNANO

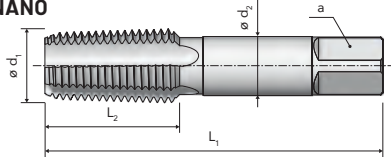

APPLICATION RANGE - CUTTING SPEED m/min

ISO	MG	A6 BRIGHT			
P	P.2	• 10-15			
	P.3	• 10-12			
	P.4	• 8-10			
K	K.2	• 10-12			



Rc	P	Ød ₁	L ₁ js 16	L ₂	L ₃	Ød ₂ h9	a h12	Z	z	Ø	A6 BRIGHT ...0062H1LA0
	[TPI]	[mm]	[mm]	[mm]	[mm]	[mm]	[mm]	[-]	[mm]	[mm]	
1/8"	28	9,728	63	17,5	-	7	5,5	4	8,2 (a)	8,2 (a)	AV0180...
1/4"	19	13,157	63	23,5	-	11	9	4	11 (a)	11 (a)	AV0140...
3/8"	19	16,662	70	24	-	12	9	4	14,5 (a)	14,5 (a)	AV0380...
1/2"	14	20,955	80	29	-	16	12	4	18 (a)	18 (a)	AV0120...
3/4"	14	26,441	100	32	-	20	16	5	23,5 (a)	23,5 (a)	AV0340...
1"	11	33,249	110	36	-	25	20	5	29,5 (a)	29,5 (a)	AV1000...
1 1/4"	11	41,91	125	44	-	32	24	5	38 (a)	38 (a)	AV1140...
1 1/2"	11	47,803	140	46	-	36	29	6	44 (a)	44 (a)	AV1120...
2"	11	59,614	160	50	-	45	35	6	55,5 (a)	55,5 (a)	AV2000...

(a) = Cylindrical hole (see page 252)



A4
ROUGHING

A4
SECOND

A4
FINISHING

A4
SET

DIN 2184-2
≤ Ø 1/4"

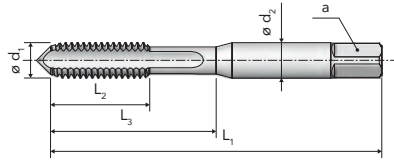

DIN 2184-2
≥ Ø 5/16"

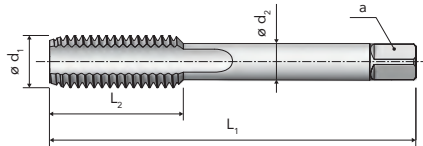

A SERIES

APPLICATION RANGE - CUTTING SPEED m/min

ISO	MG	A4 ROUGHING	A4 SECOND	A4 FINISHING	A4 SET
P	P.1-4	•	•	•	•
	P.7	•	•	•	•
K	K.2	•	•	•	•
N	N.1-3	•	•	•	•
	N.5-7	•	•	•	•

—	—	mc	mc
A (5-6)	D (4-5)	C (2-3)	C (2-3)
2,5xD	2,5xD	2,5xD	2,5xD
RH	RH	RH	RH

BSW	P	Ød ₁	L ₁ js16	L ₂	L ₃	Ød ₂ h9	a h12	z		A4 ROUGHING ...0041A1LA0	A4 SECOND ...0041A2LA0	A4 FINISHING ...0041A3LA0	A4 SET ...0041A8LA0
3/32"	48	2,381	40	9	15	2,8	2,1	3	1,9	AEA332...	AEA332...	AEA332...	AEA332...
1/8"	40	3,175	40	10	18	3,5	2,7	3	2,55	AEB180...	AEB180...	AEB180...	AEB180...
5/32"	32	3,969	45	12	21	4,5	3,4	3	3,2	AEB532...	AEB532...	AEB532...	AEB532...
3/16"	24	4,763	50	14	23	6	4,9	3	3,7	AEC316...	AEC316...	AEC316...	AEC316...
7/32"	24	5,556	56	16	28	6	4,9	3	4,5	AEC732...	AEC732...	AEC732...	AEC732...
1/4"	20	6,35	56	16	28	6	4,9	3	5,1	AED140...	AED140...	AED140...	AED140...
5/16"	18	7,938	63	22	-	6	4,9	3	6,5	AEE516...	AEE516...	AEE516...	AEE516...
3/8"	16	9,525	70	24	-	7	5,5	3	7,9	AEF380...	AEF380...	AEF380...	AEF380...
7/16"	14	11,113	70	24	-	8	6,2	3	9,25	AEF716...	AEF716...	AEF716...	AEF716...
1/2"	12	12,7	75	28	-	9	7	4	10,5	AEG120...	AEG120...	AEG120...	AEG120...
9/16"	12	14,288	80	28	-	11	9	4	12	AEG916...	AEG916...	AEG916...	AEG916...
5/8"	11	15,875	80	30	-	12	9	4	13,5	AEH580...	AEH580...	AEH580...	AEH580...
3/4"	10	19,05	95	32	-	14	11	4	16,4	AEL340...	AEL340...	AEL340...	AEL340...
7/8"	9	22,225	100	32	-	18	14,5	4	19,25	AEM780...	AEM780...	AEM780...	AEM780...
1"	8	25,4	110	36	-	18	14,5	4	22	AEP100...	AEP100...	AEP100...	AEP100...
1 1/8"	7	28,575	125	40	-	22	18	4	24,75	AEP118...	AEP118...	AEP118...	AEP118...
1 1/4"	7	31,75	125	40	-	22	18	4	27,75	AEQ114...	AEQ114...	AEQ114...	AEQ114...



A24 FC
BRIGHT

A24 FP
BRIGHT

A SERIES

DIN 2184-1
≤ Ø 3/8"

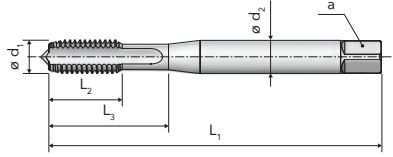

DIN 2184-1
≥ Ø 7/16"

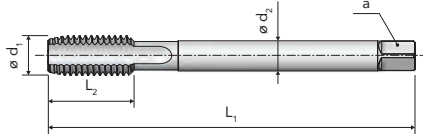

APPLICATION RANGE - CUTTING SPEED m/min

ISO	MG	A24 FC BRIGHT	A24 FP BRIGHT
P	P.2	• 10-12	• 10-12
	P.3	• 8-10	• 8-10
K	K.2	• 8-10	• 8-10



BSW	P	Ød ₁	L ₁ js 16	L ₂	L ₃	Ød ₂ h9	a h12	z	z	A24 FC BRIGHT ...024I1LA0	A24 FP BRIGHT ...024I2LA0
	[TPI]	[mm]	[mm]	[mm]	[mm]	[mm]	[mm]	[-]	[mm]		
3/32"	48	2,381	50	9	15	2,8	2,1	3	1,9	AEA332...	AEA332...
1/8"	40	3,175	56	11	17	3,5	2,7	3	2,55	AEB180...	AEB180...
5/32"	32	3,969	63	12	21	4,5	3,4	3	3,2	AEB532...	AEB532...
3/16"	24	4,763	70	14	24	6	4,9	3	3,7	AEC316...	AEC316...
7/32"	24	5,556	80	15	28	6	4,9	3	4,5	AEC732...	AEC732...
1/4"	20	6,35	80	16	29	7	5,5	3	5,1	AED140...	AED140...
5/16"	18	7,938	90	18	33	8	6,2	3	6,5	AEE516...	AEE516...
3/8"	16	9,525	100	20	36	10	8	3	7,9	AEF380...	AEF380...
7/16"	14	11,113	100	22	-	8	6,2	3	9,25	AEF716...	AEF716...
1/2"	12	12,7	110	25	-	9	7	3	10,5	AEG120...	AEG120...
9/16"	12	14,288	110	27	-	11	9	3	12	AEG916...	AEG916...
5/8"	11	15,875	110	28	-	12	9	3	13,5	AEH580...	AEH580...
3/4"	10	19,05	125	32	-	14	11	4	16,4	AEL340...	AEL340...
7/8"	9	22,225	140	32	-	18	14,5	4	19,25	AEM780...	AEM780...
1"	8	25,4	160	36	-	18	14,5	4	22	AEP100...	AEP100...
1 1/8"	7	28,575	180	40	-	22	18	4	24,75	AEP118...	AEP118...
1 1/4"	7	31,75	180	40	-	22	18	4	27,75	AEQ114...	AEQ114...



A31
BRIGHT

A31
TiN

DIN 2184-1
≤ Ø 3/8"

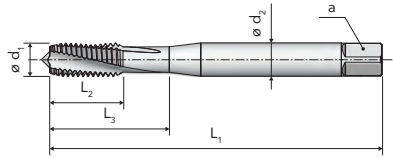

DIN 2184-1
≥ Ø 7/16"

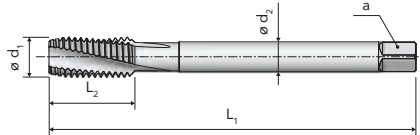

A
SERIES

APPLICATION RANGE - CUTTING SPEED m/min

ISO	MG	A31 BRIGHT	A31 TiN
P	P.1	● 18-20	● 30-35
	P.2	● 15-18	● 25-30
	P.3	● 12-15	● 20-25
	P.4	● 10-12	● 15-20
	P.5		● 5-10
K	K.2	● 12-15	● 20-25
N	N.1	● 18-20	
	N.2-3	● 15-18	● 25-30
	N.5	● 15-18	
	N.6	● 12-15	● 20-25



BSW	P	Ød ₁	L ₁ js16	L ₂	L ₃	Ød ₂ h9	a h12	z	z	A31 BRIGHT ...0311A1LA0	A31 TiN ...0311A1LDO
	[TPI]	[mm]	[mm]	[mm]	[mm]	[mm]	[mm]	[-]	[mm]		
3/32"	48	2,381	50	9	15	2,8	2,1	3	1,9	AEA332...	AEA332...
1/8"	40	3,175	56	11	17	3,5	2,7	3	2,55	AEB180...	AEB180...
5/32"	32	3,969	63	12	21	4,5	3,4	3	3,2	AEB532...	AEB532...
3/16"	24	4,763	70	14	24	6	4,9	3	3,7	AEC316...	AEC316...
7/32"	24	5,556	80	15	28	6	4,9	3	4,5	AEC732...	AEC732...
1/4"	20	6,35	80	16	29	7	5,5	3	5,1	AED140...	AED140...
5/16"	18	7,938	90	18	33	8	6,2	3	6,5	AEE516...	AEE516...
3/8"	16	9,525	100	20	36	10	8	3	7,9	AEF380...	AEF380...
7/16"	14	11,113	100	22	-	8	6,2	3	9,25	AEF716...	AEF716...
1/2"	12	12,7	110	25	-	9	7	3	10,5	AEG120...	AEG120...
9/16"	12	14,288	110	27	-	11	9	3	12	AEG916...	AEG916...
5/8"	11	15,875	110	28	-	12	9	3	13,5	AEH580...	AEH580...
3/4"	10	19,05	125	32	-	14	11	4	16,4	AEL340...	AEL340...
7/8"	9	22,225	140	32	-	18	14,5	4	19,25	AEM780...	AEM780...
1"	8	25,4	160	36	-	18	14,5	4	22	AEP100...	AEP100...
1 1/8"	7	28,575	180	40	-	22	18	4	24,75	AEP118...	
1 1/4"	7	31,75	180	40	-	22	18	4	27,75	AEQ114...	





A6 B
BRIGHT

A SERIES

NORM VERGNANO

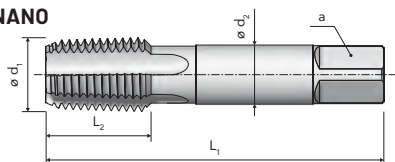

APPLICATION RANGE - CUTTING SPEED m/min

ISO	MG	A6 B BRIGHT			
P	P.2	• 10-15			
	P.3	• 10-12			
	P.4	• 8-10			
K	K.2	• 10-12			



NPT	P	Ød ₁	L ₁ js 16	L ₂	L ₃	Ød ₂ h9	a h12	Z	⌀	A6 B BRIGHT ...0062H1LA0
	[TPI]	[mm]	[mm]	[mm]	[mm]	[mm]	[mm]	[-]	[mm]	
1/16"	27	7,938	63	12	-	6	4,9	4	6,15 (a)	AZ0116...
1/8"	27	10,287	63	12	-	7	5,5	4	8,5 (a)	AZ0180...
1/4"	18	13,716	63	18	-	11	9	4	11 (a)	AZ0140...
3/8"	18	17,145	70	18	-	12	9	4	14,5 (a)	AZ0380...
1/2"	14	21,336	80	23	-	16	12	4	17,85 (a)	AZ0120...
3/4"	14	26,67	100	24	-	20	16	5	23,2 (a)	AZ0340...
1"	11,5	33,401	110	30	-	25	20	5	29 (a)	AZ1000...
1 1/4"	11,5	42,164	125	32	-	32	24	5	37,8 (a)	AZ1140...
1 1/2"	11,5	48,26	140	32	-	36	29	6	44 (a)	AZ1120...
2"	11,5	60,325	160	34	-	45	35	6	56 (a)	AZ2000...

(a) = Cylindrical hole (see page 252)



A6 BZ
BRIGHT

DIN 374

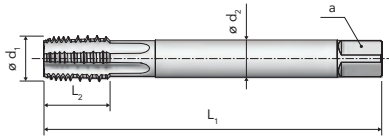

A
SERIES

APPLICATION RANGE - CUTTING SPEED m/min

ISO	MG	A6 BZ BRIGHT			
P	P.1	• 12-15			
	P.7	• 2-3			
M	M.1	• 2-3			
N	N.1-2	• 12-15			
	N.5	• 10-12			
	N.6	• 6-8			



NPT	P	$\varnothing d_1$	L_1 js16	L_2	L_3	$\varnothing d_2$ h9	a h12	z		A6 BZ BRIGHT ...0062H10A0
	[TPI]	[mm]	[mm]	[mm]	[mm]	[mm]	[mm]	[-]	[mm]	
1/16"	27	7,938	90	12	-	6	4,9	3	6,15(a)	AZ0116...
1/8"	27	10,287	100	12	-	7	5,5	5	8,5(a)	AZ0180...
1/4"	18	13,716	100	18	-	11	9	5	11(a)	AZ0140...
3/8"	18	17,145	110	18	-	12	9	5	14,5(a)	AZ0380...
1/2"	14	21,336	140	23	-	16	12	5	17,85(a)	AZ0120...
3/4"	14	26,67	150	24	-	20	16	5	23,2(a)	AZ0340...
1"	11,5	33,401	170	30	-	25	20	5	29(a)	AZ1000...

(a) = Cylindrical hole (see page 252)



A6 F
BRIGHT

A SERIES

NORM VERGNANO

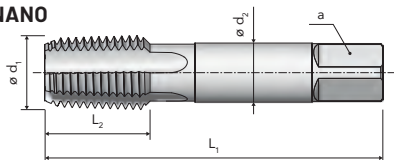

APPLICATION RANGE - CUTTING SPEED m/min

ISO	MG	A6 F BRIGHT			
P	P.2	• 10-15			
	P.3	• 10-12			
	P.4	• 8-10			
K	K.2	• 10-12			



NPTF	P	Ød ₁	L ₁ js 16	L ₂	L ₃	Ød ₂ h9	a h12	Z		A6 F BRIGHT ...0062H1PA0
	[TPI]	[mm]	[mm]	[mm]	[mm]	[mm]	[mm]	[-]	[mm]	
1/16"	27	7,938	63	12	-	6	4,9	4	6,15 (a)	AZ0116...
1/8"	27	10,287	63	12	-	7	5,5	4	8,5 (a)	AZ0180...
1/4"	18	13,716	63	18	-	11	9	4	11 (a)	AZ0140...
3/8"	18	17,145	70	18	-	12	9	4	14,5 (a)	AZ0380...
1/2"	14	21,336	80	23	-	16	12	4	17,8 (a)	AZ0120...
3/4"	14	26,67	100	24	-	20	16	5	23 (a)	AZ0340...
1"	11,5	33,401	110	30	-	25	20	5	29 (a)	AZ1000...
1 1/4"	11,5	42,164	125	32	-	32	24	5	37,8 (a)	AZ1140...
1 1/2"	11,5	48,26	140	32	-	36	29	6	43,8 (a)	AZ1120...
2"	11,5	60,325	160	34	-	45	35	6	56 (a)	AZ2000...

(a) = Cylindrical hole (see page 252)



A6 FZ
BRIGHT

DIN 374

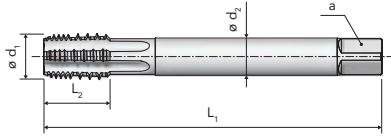

A SERIES

APPLICATION RANGE - CUTTING SPEED m/min

ISO	MG	A6 FZ BRIGHT			
P	P.1	• 12-15			
	P.7	• 2-3			
M	M.1	• 2-3			
N	N.1-2	• 12-15			
	N.5	• 10-12			
	N.6	• 6-8			



NPTF	P	$\varnothing d_1$	L_1 js16	L_2	L_3	$\varnothing d_2$ h9	a h12	z		A6 FZ BRIGHT ...0062H1RA0
	[TPI]	[mm]	[mm]	[mm]	[mm]	[mm]	[mm]	[-]	[mm]	
1/16"	27	7,938	90	12	-	6	4,9	3	6,15 (a)	AZ0116...
1/8"	27	10,287	100	12	-	7	5,5	5	8,5 (a)	AZ0180...
1/4"	18	13,716	100	18	-	11	9	5	11 (a)	AZ0140...
3/8"	18	17,145	110	18	-	12	9	5	14,5 (a)	AZ0380...
1/2"	14	21,336	140	23	-	16	12	5	17,8 (a)	AZ0120...
3/4"	14	26,67	150	24	-	20	16	5	23 (a)	AZ0340...
1"	11,5	33,401	170	30	-	25	20	5	29 (a)	AZ1000...

(a) = Cylindrical hole (see page 252)



P SERIES

HIGH PERFORMANCE TAPS

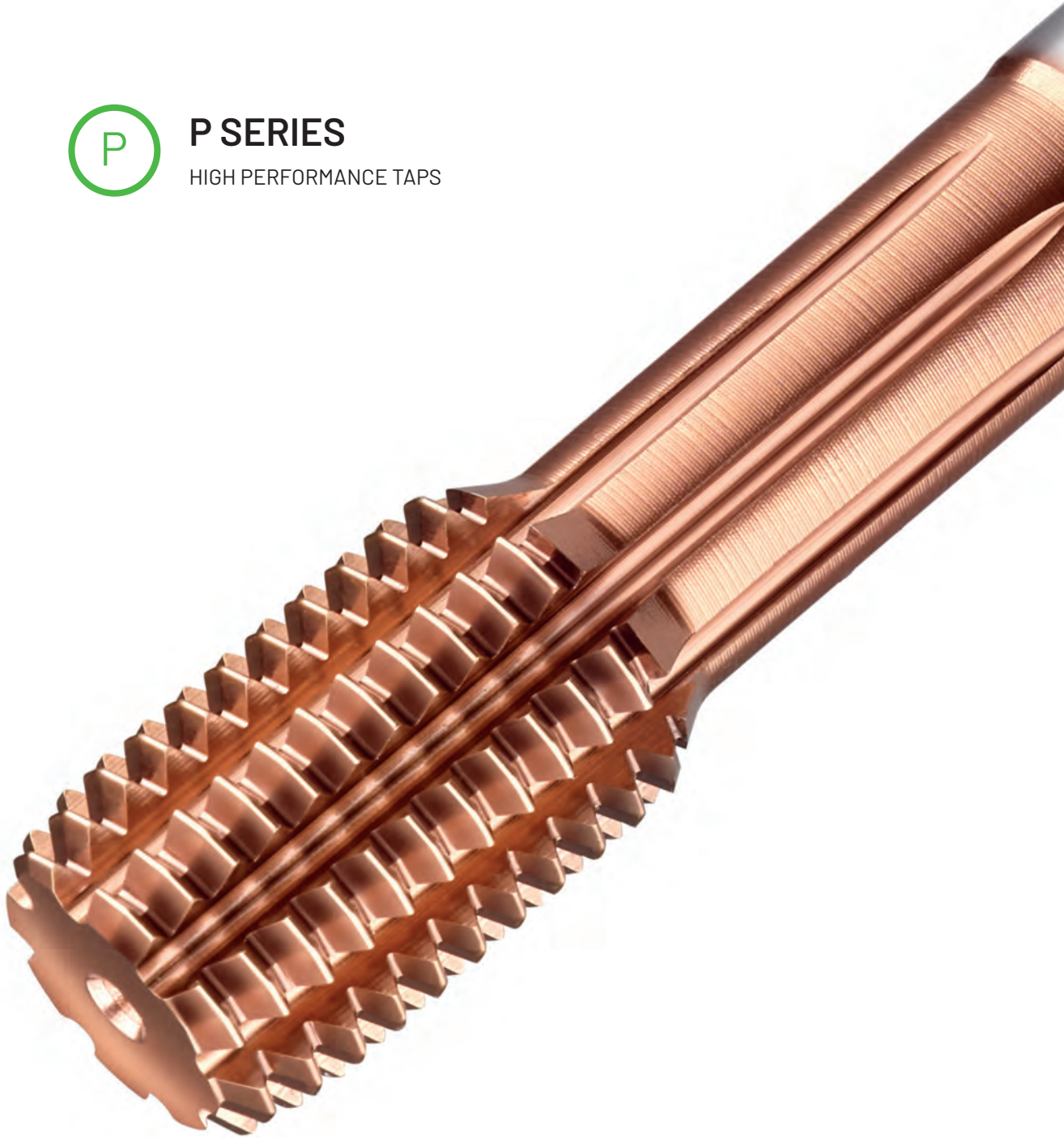



P43
V-MAXX

BP43
V-MAXX

P43 E
V-MAXX

BP43 E
V-MAXX

DIN 371
≤ M10

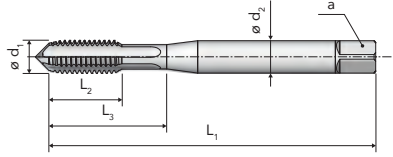

DIN 376
≥ M12

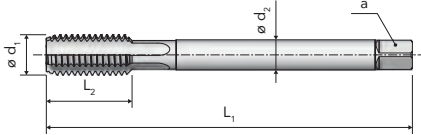

APPLICATION RANGE - CUTTING SPEED m/min

ISO	MG	P43 V-MAXX	BP43 V-MAXX	P43 E V-MAXX	BP43 E V-MAXX
K	K.1	● 40-50	● 40-50	● 40-50	● 40-50
	N.4	● 40-50	● 40-50	● 40-50	● 40-50
N	N.7	● 40-50	● 40-50	● 40-50	● 40-50
	N.9-10	● 45-55	● 45-55	● 45-55	● 45-55



$\varnothing d_1$	P	L_1 js 16	L_2	L_3	$\varnothing d_2$ h9	a h12	Z		P43 V-MAXX ...0435A1AV0	BP43 V-MAXX ...0435M1AV0	P43 E V-MAXX ...0435A3AV0	BP43 E V-MAXX ...0435M3AV0
[mm]	[mm]	[mm]	[mm]	[mm]	[mm]	[mm]	[-]	[mm]				
M 3	0,5	56	10	18	3,5	2,7	3	2,5	A00030...			
4	0,7	63	12	21	4,5	3,4	4	3,3	A00040...		A00040...	
5	0,8	70	14	24,5	6	4,9	4	4,2	A00050...	A00050...	A00050...	A00050...
6	1	80	16	29	6	4,9	4	5	A00060...	A00060...	A00060...	A00060...
8	1,25	90	18	33	8	6,2	4	6,8	A00080...	A00080...	A00080...	A00080...
10	1,5	100	20	36	10	8	4	8,5	A00100...	A00100...	A00100...	A00100...
12	1,75	110	24	-	9	7	4	10,2	A00120...	A00120...	A00120...	A00120...
14	2	110	25	-	11	9	4	12	A00140...	A00140...		
16	2	110	28	-	12	9	4	14	A00160...	A00160...		
18	2,5	125	32	-	14	11	4	15,5	A00180...	A00180...		
20	2,5	140	32	-	16	12	4	17,5	A00200...	A00200...		



P130
BRIGHT

P130
V-MAXX

DIN 371
≤ M10

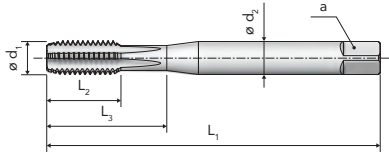

DIN 376
≥ M12

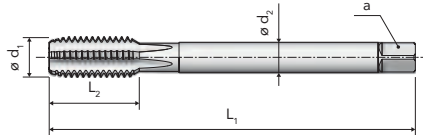

APPLICATION RANGE - CUTTING SPEED m/min

ISO	MG	P130 BRIGHT	P130 V-MAXX
P	P.6	• 2-3	• 5-8
N	N.8	• 3-5	• 8-10



P SERIES

$\varnothing d_1$	P	L_1 js 16	L_2	L_3	$\varnothing d_2$ h9	a h12	Z		P130 BRIGHT ...1305A1AA0	P130 V-MAXX ...1305A1AV0
[mm]	[mm]	[mm]	[mm]	[mm]	[mm]	[mm]	[-]	[mm]		
M 4	0,7	63	12	21	4,5	3,4	4	3,4(*)	A00040...	A00040...
5	0,8	70	14	24,5	6	4,9	4	4,3(*)	A00050...	A00050...
6	1	80	16	29	6	4,9	5	5,1(*)	A00060...	A00060...
8	1,25	90	18	33	8	6,2	5	6,9(*)	A00080...	A00080...
10	1,5	100	20	36	10	8	5	8,6(*)	A00100...	A00100...
12	1,75	110	24	-	9	7	5	10,4(*)	A00120...	A00120...
14	2	110	25	-	11	9	5	12,2(*)	A00140...	A00140...
16	2	110	28	-	12	9	5	14,2(*)	A00160...	A00160...
20	2,5	140	32	-	16	12	5	17,7(*)	A00200...	A00200...

(*)= The hole diameters are oversized



P15
TiN

P15
TiH1

P15 6GX
TiH1

BP15
TiH1

DIN 371
≤ M10

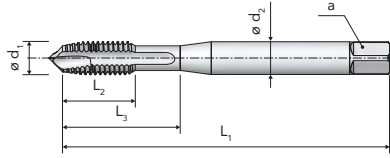

DIN 376
≥ M12

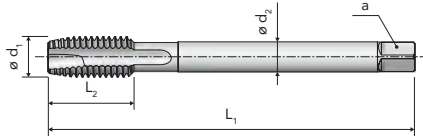

APPLICATION RANGE - CUTTING SPEED m/min

ISO	MG	P15 TiN	P15 TiH1	P15 6GX TiH1	BP15 TiH1
P	P.3	● 25-35	● 25-35	● 25-35	● 25-35
	P.4	● 20-30	● 20-30	● 20-30	● 20-30
	P.5	● 10-20	● 10-20	● 10-20	● 10-20
	P.6	● 8-10	● 8-10	● 8-10	● 8-10
	P.7	● 10-15	● 10-15	● 10-15	● 10-15
M	M.1	● 10-15	● 10-15	● 10-15	● 10-15
	M.2	● 6-8	● 6-8	● 6-8	● 6-8
K	K.2	● 25-35	● 25-35	● 25-35	● 25-35
N	N.2-3	● 30-40	● 30-40	● 30-40	● 30-40
	N.6	● 25-35	● 25-35	● 25-35	● 25-35



Ød ₁	P	L ₁ js 16	L ₂	L ₃	Ød ₂ h9	a h12	Z		P15 TiN ...0154A2AD0	P15 TiH1 ...0154A2AH0	P15 6GX TiH1 ...0154A2CH0	BP15 TiH1 ...0154M2AH0
[mm]	[mm]	[mm]	[mm]	[mm]	[mm]	[mm]	[-]	[mm]				
M1(*)	0,25	40	5,5	7,5	2,5	2,1	2	0,75	A00010...	A00010...		
1,2(*)	0,25	40	5,5	7,5	2,5	2,1	2	0,95	A00012...	A00012...		
1,4(*)	0,3	40	7	10	2,5	2,1	2	1,1	A00014...	A00014...		
1,6	0,35	40	8	11	2,5	2,1	2	1,25	A00016...	A00016...		
1,7	0,35	40	8	11	2,5	2,1	2	1,35	A00017...	A00017...		
1,8	0,35	40	8	11	2,5	2,1	2	1,45	A00018...	A00018...		
2	0,4	45	7	11	2,8	2,1	3	1,6	A00020...	A00020...		
2,5	0,45	50	9	15	2,8	2,1	3	2,05	A00025...	A00025...		
3	0,5	56	10	18	3,5	2,7	3	2,5	A00030...	A00030...		
4	0,7	63	12	21	4,5	3,4	3	3,3	A00040...	A00040...	A00040...	
5	0,8	70	14	24,5	6	4,9	3	4,2	A00050...	A00050...	A00050...	A00050...
6	1	80	16	29	6	4,9	3	5	A00060...	A00060...	A00060...	A00060...
8	1,25	90	18	33	8	6,2	3	6,8	A00080...	A00080...	A00080...	A00080...
10	1,5	100	20	36	10	8	3	8,5	A00100...	A00100...	A00100...	A00100...
12	1,75	110	24	-	9	7	4	10,2	A00120...	A00120...	A00120...	A00120...
14	2	110	25	-	11	9	4	12	A00140...	A00140...	A00140...	A00140...
16	2	110	28	-	12	9	4	14	A00160...	A00160...	A00160...	A00160...
18	2,5	125	32	-	14	11	4	15,5	A00180...	A00180...	A00180...	A00180...
20	2,5	140	32	-	16	12	4	17,5	A00200...	A00200...		
24	3	160	36	-	18	14,5	4	21	A00240...	A00240...		
27	3	160	36	-	20	16	4	24	A00270...	A00270...		
30	3,5	180	40	-	22	18	5	26,5	A00300...	A00300...		
33	3,5	180	40	-	25	20	5	29,5	A00330...	A00330...		
36	4	200	55	-	28	22	5	32	A00360...	A00360...		

(*)= Tolerance 5HX



P150
G-MAXX

DIN 371
≤ M10

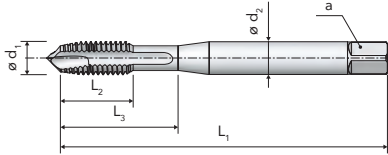

DIN 376
≥ M12

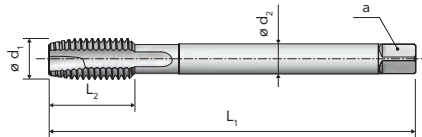

APPLICATION RANGE - CUTTING SPEED m/min

ISO	MG	P150 G-MAXX			
P	P.7	• 15-20			
M	M.1	• 15-20			
	M.2	• 10-12			



P SERIES

Ød ₁	P	L ₁ js16	L ₂	L ₃	Ød ₂ h9	a h12	Z	z	P150 G-MAXX ...1505A2AX0
[mm]	[mm]	[mm]	[mm]	[mm]	[mm]	[mm]	[-]	[mm]	
M 3	0,5	56	10	18	3,5	2,7	3	2,5	A00030..
4	0,7	63	12	21	4,5	3,4	3	3,3	A00040..
5	0,8	70	14	24,5	6	4,9	3	4,2	A00050..
6	1	80	16	29	6	4,9	3	5	A00060..
8	1,25	90	18	33	8	6,2	3	6,8	A00080..
10	1,5	100	20	36	10	8	3	8,5	A00100..
12	1,75	110	24	-	9	7	3	10,2	A00120..
14	2	110	25	-	11	9	3	12	A00140..
16	2	110	28	-	12	9	3	14	A00160..
18	2,5	125	32	-	14	11	4	15,5	A00180..
20	2,5	140	32	-	16	12	4	17,5	A00200..



P29
BRIGHT

P29
TiN

P29
TiH1

BP29
TiH1

DIN 371
≤ M10

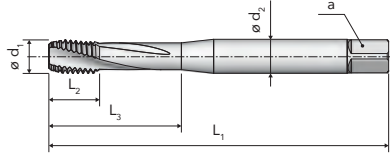

DIN 376
≥ M12

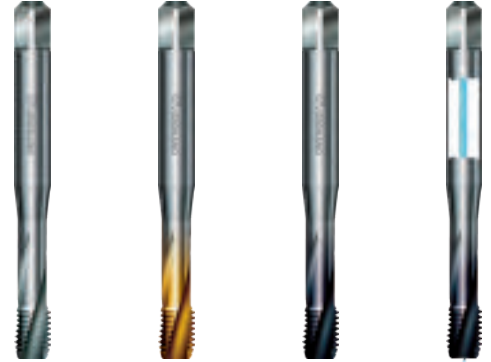
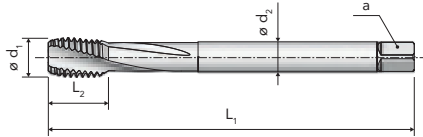

APPLICATION RANGE - CUTTING SPEED m/min

ISO	MG	P29 BRIGHT	P29 TiN	P29 TiH1	BP29 TiH1
P	P.3	● 15-18	● 25-30	● 25-30	● 25-30
	P.4	● 12-15	● 20-25	● 20-25	● 20-25
	P.5	● 8-10	● 10-15	● 10-15	● 10-15
	P.6	● 3-5	● 5-10	● 5-10	● 5-10
	P.7	● 8-10	● 10-15	● 10-15	● 10-15
K	K.2	● 15-18	● 25-30	● 25-30	● 25-30
N	N.3	● 15-18	● 25-30	● 25-30	● 25-30
	N.6	● 15-18	● 25-30	● 25-30	● 25-30
	N.7	● 12-15	● 20-25	● 20-25	● 20-25
S	S.2	● 2-3		● 2-3	● 2-3
	S.4	● 2-3	● 2-3	● 2-3	● 2-3



$\varnothing d_1$	P	L_1 js 16	L_2	L_3	$\varnothing d_2$ h9	a h12	Z		P29 BRIGHT ...0295A1AA0	P29 TiN ...0295A1AD0	P29 TiH1 ...0295A1AH0	BP29 TiH1 ...0295M1AH0
[mm]	[mm]	[mm]	[mm]	[mm]	[mm]	[mm]	[-]	[mm]				
M 2	0,4	45	5	12	2,8	2,1	3	1,6	A00020...	A00020...	A00020...	
2,5	0,45	50	6	15	2,8	2,1	3	2,05	A00025...	A00025...	A00025...	
3	0,5	56	5	18	3,5	2,7	3	2,5	A00030...	A00030...	A00030...	
4	0,7	63	7	21	4,5	3,4	3	3,3	A00040...	A00040...	A00040...	
5	0,8	70	9	25	6	4,9	3	4,2	A00050...	A00050...	A00050...	A00050...
6	1	80	11	30	6	4,9	3	5	A00060...	A00060...	A00060...	A00060...
8	1,25	90	12	35	8	6,2	3	6,8	A00080...	A00080...	A00080...	A00080...
10	1,5	100	13	39	10	8	3	8,5	A00100...	A00100...	A00100...	A00100...
12	1,75	110	15	-	9	7	3	10,2	A00120...	A00120...	A00120...	A00120...
14	2	110	18	-	11	9	3	12	A00140...	A00140...	A00140...	A00140...
16	2	110	18	-	12	9	3	14	A00160...	A00160...	A00160...	A00160...
18	2,5	125	20	-	14	11	4	15,5	A00180...	A00180...	A00180...	A00180...
20	2,5	140	20	-	16	12	4	17,5	A00200...	A00200...	A00200...	A00200...
24	3	160	25	-	18	14,5	4	21	A00240...	A00240...	A00240...	
27	3	160	25	-	20	16	4	24	A00270...	A00270...	A00270...	
30	3,5	180	29	-	22	18	4	26,5	A00300...	A00300...	A00300...	
36	4	200	34	-	28	22	4	32	A00360...	A00360...	A00360...	



P29 E
TiH1

DIN 371
≤ M10

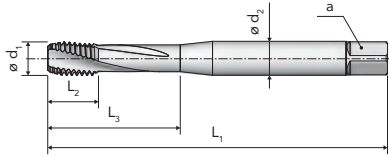

DIN 376
≥ M12

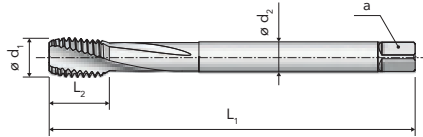

APPLICATION RANGE - CUTTING SPEED m/min

ISO	MG	P29 E TiH1			
P	P.3	• 25-30			
	P.4	• 20-25			
	P.5	• 10-15			
	P.6	• 5-10			
	P.7	• 10-15			
K	K.2	• 25-30			
N	N.3	• 25-30			
	N.6	• 25-30			
	N.7	• 20-25			
S	S.2	• 2-3			
	S.4	• 2-3			



P SERIES

$\varnothing d_1$	P	L_1 js16	L_2	L_3	$\varnothing d_2$ h9	a h12	Z		P29 E TiH1 ...0295A3AH0
[mm]	[mm]	[mm]	[mm]	[mm]	[mm]	[mm]	[-]	[mm]	
M 3	0,5	56	5	18	3,5	2,7	3	2,5	A00030...
4	0,7	63	7	21	4,5	3,4	3	3,3	A00040...
5	0,8	70	9	25	6	4,9	3	4,2	A00050...
6	1	80	11	30	6	4,9	3	5	A00060...
8	1,25	90	12	35	8	6,2	3	6,8	A00080...
10	1,5	100	13	39	10	8	3	8,5	A00100...
12	1,75	110	15	-	9	7	3	10,2	A00120...



P70
TiN

P70
TiH1

P70 6GX
TiH1

P70 7GX
TiH1

DIN 371
≤ M10

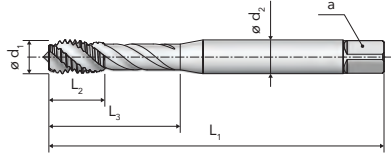

DIN 376
≥ M12

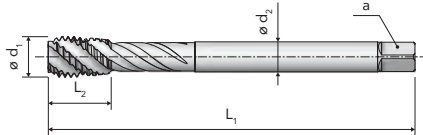

APPLICATION RANGE - CUTTING SPEED m/min

ISO	MG	P70 TiN	P70 TiH1	P70 6GX TiH1	P70 7GX TiH1
P	P.3	● 20-30	● 20-30	● 20-30	● 20-30
	P.4	● 15-25	● 15-25	● 15-25	● 15-25
	P.5	● 5-15	● 5-15	● 5-15	● 5-15
	P.7	● 8-10	● 8-10	● 8-10	● 8-10
M	M.1	● 8-10	● 8-10	● 8-10	● 8-10
	M.2	● 5-7	● 5-7	● 5-7	● 5-7
K	K.2	● 20-30	● 20-30	● 20-30	● 20-30
N	N.3	● 25-35	● 25-35	● 25-35	● 25-35
	N.6	● 25-35	● 25-35	● 25-35	● 25-35
S	S.1		● 10-15	● 10-15	● 10-15
	S.3	● 10-15	● 10-15	● 10-15	● 10-15



Ød ₁	P	L ₁ js 16	L ₂	L ₃	Ød ₂ h9	a h12	z		P70 TiN ...0704A1AD0	P70 TiH1 ...0704A1AH0	P70 6GX TiH1 ...0704A1CH0	P70 7GX TiH1 ...0704A1DH0
[mm]	[mm]	[mm]	[mm]	[mm]	[mm]	[mm]	[-]	[mm]				
M 2	0,4	45	6	12	2,8	2,1	3	1,6	A00020...	A00020...		
2,5	0,45	50	6,5	15	2,8	2,1	3	2,05	A00025...	A00025...		
3	0,5	56	7	15	3,5	2,7	3	2,5	A00030...	A00030...	A00030...	A00030...
4	0,7	63	8,5	21	4,5	3,4	3	3,3	A00040...	A00040...	A00040...	A00040...
5	0,8	70	10	24,5	6	4,9	3	4,2	A00050...	A00050...	A00050...	A00050...
6	1	80	12	29	6	4,9	3	5	A00060...	A00060...	A00060...	A00060...
8	1,25	90	14	33	8	6,2	3	6,8	A00080...	A00080...	A00080...	A00080...
10	1,5	100	17	39	10	8	3	8,5	A00100...	A00100...	A00100...	A00100...
12	1,75	110	18	-	9	7	4	10,2	A00120...	A00120...	A00120...	A00120...
14	2	110	20,5	-	11	9	4	12	A00140...	A00140...	A00140...	
16	2	110	20,5	-	12	9	4	14	A00160...	A00160...	A00160...	
18	2,5	125	25,5	-	14	11	4	15,5	A00180...	A00180...	A00180...	
20	2,5	140	25,5	-	16	12	4	17,5	A00200...	A00200...	A00200...	
NEW 22	2,5	140	25,5	-	18	14,5	4	19,5	A00220...	A00220...		
24	3	160	32	-	18	14,5	4	21	A00240...	A00240...		
27	3	160	32	-	20	16	5	24	A00270...	A00270...		
30	3,5	180	37	-	22	18	5	26,5	A00300...	A00300...		
33	3,5	180	37	-	25	20	5	29,5	A00330...	A00330...		
36	4	200	42	-	28	22	5	32	A00360...	A00360...		
42	4,5	200	45	-	32	24	5	37,5	A00420...	A00420...		



BP70
TiH1

DIN 371
≤ M10

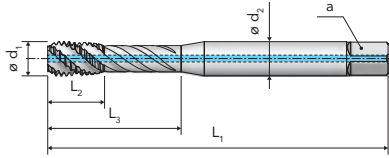

DIN 376
≥ M12

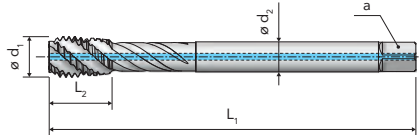

P SERIES

APPLICATION RANGE - CUTTING SPEED m/min

ISO	MG	BP70 TiH1			
P	P.3	• 20-30			
	P.4	• 15-25			
	P.5	• 5-15			
	P.7	• 8-10			
M	M.1	• 8-10			
	M.2	• 5-7			
K	K.2	• 20-30			
N	N.3	• 25-35			
	N.6	• 25-35			
S	S.1	• 10-15			
	S.3	• 10-15			



$\varnothing d_1$	P	L_1 js16	L_2	L_3	$\varnothing d_2$ h9	a h12	Z		BP70 TiH1 ...0704M1AH0
[mm]	[mm]	[mm]	[mm]	[mm]	[mm]	[mm]	[-]	[mm]	
M5	0,8	70	10	24,5	6	4,9	3	4,2	A00050...
6	1	80	12	29	6	4,9	3	5	A00060...
8	1,25	90	14	33	8	6,2	3	6,8	A00080...
10	1,5	100	17	39	10	8	3	8,5	A00100...
12	1,75	110	18	-	9	7	4	10,2	A00120...
14	2	110	20,5	-	11	9	4	12	A00140...
16	2	110	20,5	-	12	9	4	14	A00160...
20	2,5	140	25,5	-	16	12	4	17,5	A00200...
24	3	160	32	-	18	14,5	4	21	A00240...



P70 E
TiN

P70 E
TiH1

P70 E 6GX
TiH1

DIN 371
≤ M10

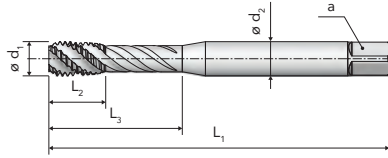

DIN 376
≥ M12

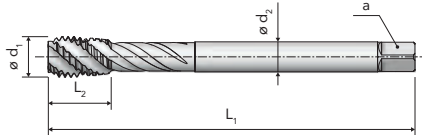

APPLICATION RANGE - CUTTING SPEED m/min

ISO	MG	P70 E TiN	P70 E TiH1	P70 E 6GX TiH1
P	P.3	● 20-30	● 20-30	● 20-30
	P.4	● 15-25	● 15-25	● 15-25
	P.5	● 5-15	● 5-15	● 5-15
	P.7	● 8-10	● 8-10	● 8-10
M	M.1	● 8-10	● 8-10	● 8-10
	M.2	● 5-7	● 5-7	● 5-7
K	K.2	● 20-30	● 20-30	● 20-30
N	N.3	● 25-35	● 25-35	● 25-35
	N.6	● 25-35	● 25-35	● 25-35
S	S.1		● 10-15	● 10-15
	S.3	● 10-15	● 10-15	● 10-15



Ød ₁	P	L ₁ js 16	L ₂	L ₃	Ød ₂ h9	a h12	Z		P70 E TiN ...0704A3ADO	P70 E TiH1 ...0704A3AHO	P70 E 6GX TiH1 ...0704A3CHO
[mm]	[mm]	[mm]	[mm]	[mm]	[mm]	[mm]	[-]	[mm]			
M 2	0,4	45	6	12	2,8	2,1	3	1,6	A00020...	A00020...	
2,5	0,45	50	6,5	15	2,8	2,1	3	2,05	A00025...	A00025...	
3	0,5	56	7	15	3,5	2,7	3	2,5	A00030...	A00030...	A00030...
4	0,7	63	8,5	21	4,5	3,4	3	3,3	A00040...	A00040...	A00040...
5	0,8	70	10	24,5	6	4,9	3	4,2	A00050...	A00050...	A00050...
6	1	80	12	29	6	4,9	3	5	A00060...	A00060...	A00060...
8	1,25	90	14	33	8	6,2	4	6,8	A00080...	A00080...	A00080...
10	1,5	100	17	39	10	8	4	8,5	A00100...	A00100...	A00100...
12	1,75	110	18	-	9	7	4	10,2	A00120...	A00120...	A00120...
14	2	110	20,5	-	11	9	5	12	A00140...	A00140...	A00140...
16	2	110	20,5	-	12	9	5	14	A00160...	A00160...	A00160...
20	2,5	140	25,5	-	16	12	5	17,5	A00200...	A00200...	

HIGH PERFORMANCE MACHINE TAPS for blind holes
40° spiral flutes / back tapered / long and through shank



P76 L
TiH1

NORM VERGNANO

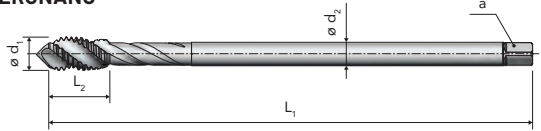

APPLICATION RANGE - CUTTING SPEED m/min

ISO	MG	P76 L TiH1			
P	P.3	• 20-30			
	P.4	• 15-25			
	P.5	• 5-15			
	P.7	• 8-10			
M	M.1	• 8-10			
	M.2	• 5-7			
K	K.2	• 20-30			
N	N.3	• 25-35			
	N.6	• 25-35			
S	S.1	• 10-15			
	S.3	• 10-15			



P SERIES

Ød ₁	P	L ₁ js16	L ₂	L ₃	Ød ₂ h9	a h12	Z	z	P76 L TiH1 ...0763L1AH0
[mm]	[mm]	[mm]	[mm]	[mm]	[mm]	[mm]	[-]	[mm]	
M 4	0,7	112	9	-	2,8	2,1	3	3,3	A00040...
5	0,8	125	10	-	3,5	2,7	3	4,2	A00050...
6	1	125	12	-	4,5	3,4	3	5	A00060...
8	1,25	140	15	-	6	4,9	3	6,8	A00080...
10	1,5	160	17,5	-	7	5,5	3	8,5	A00100...
12	1,75	180	18	-	9	7	3	10,2	A00120...
16	2	220	20,5	-	12	9	4	14	A00160...
20	2,5	280	24,5	-	16	12	4	17,5	A00200...



P170
G-MAXX

NEW
P170 E
G-MAXX

NEW
BP170
G-MAXX

DIN 371
≤ M10

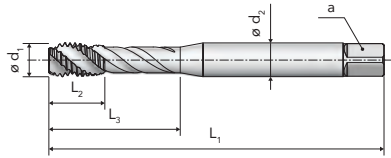

DIN 376
≥ M12

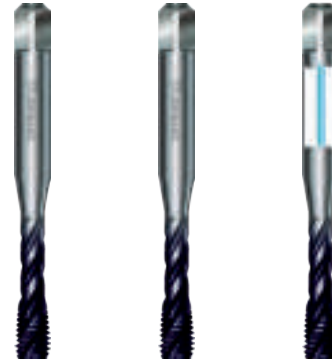
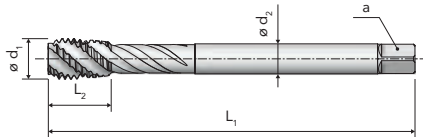

APPLICATION RANGE - CUTTING SPEED m/min

ISO	MG	P170 G-MAXX	P170 E G-MAXX	BP170 E G-MAXX
P	P.7	● 10-15	● 10-15	● 10-15
M	M.1	● 10-15	● 10-15	● 10-15
	M.2	● 6-8	● 6-8	● 6-8



Ød ₁	P	L ₁ js 16	L ₂	L ₃	Ød ₂ h9	a h12	Z		P170 G-MAXX ...1704A1AX0	P170 E G-MAXX ...1704A3AX0	BP170 G-MAXX ...1704M1AX0
[mm]	[mm]	[mm]	[mm]	[mm]	[mm]	[mm]	[-]	[mm]			
M 3	0,5	56	7	15	3,5	2,7	3	2,5	A00030..	A00030..	
4	0,7	63	8,5	21	4,5	3,4	3	3,3	A00040..	A00040..	
5	0,8	70	10	24,5	6	4,9	3	4,2	A00050..	A00050..	A00050..
6	1	80	12	29	6	4,9	3	5	A00060..	A00060..	A00060..
8	1,25	90	14	33	8	6,2	3 ⁽¹⁾	6,8	A00080..	A00080..	A00080..
10	1,5	100	17	39	10	8	3 ⁽¹⁾	8,5	A00100..	A00100..	A00100..
12	1,75	110	18	-	9	7	4	10,2	A00120..	A00120..	A00120..
14	2	110	20,5	-	11	9	4	12	A00140..		
16	2	110	20,5	-	12	9	4 ⁽²⁾	14	A00160..	A00160..	A00160..
18	2,5	125	25,5	-	14	11	4	15,5	A00180..		
20	2,5	140	25,5	-	16	12	4 ⁽²⁾	17,5	A00200..	A00200..	A00200..

⁽¹⁾: P170 E z= 4 / ⁽²⁾: P170 E z= 5



NEW
P80
V-MAXX

NEW
P80 6GX
V-MAXX

NEW
P80 7GX
V-MAXX

DIN 2174 (371)
≤ M10

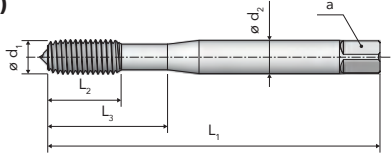

DIN 2174 (376)
≥ M12

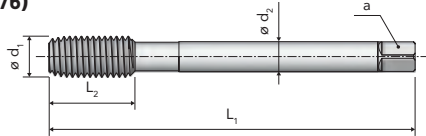

APPLICATION RANGE - CUTTING SPEED m/min

ISO	MG	P80 V-MAXX	P80 6GX V-MAXX	P80 7GX V-MAXX
P	P.1-2	• 20-25	• 20-25	• 20-25
	P.3	• 15-20	• 15-20	• 15-20
N	N.1-2	• 20-25	• 20-25	• 20-25
	N.3	• 15-20	• 15-20	• 15-20
	N.5-6	• 20-25	• 20-25	• 20-25

6HX

6GX

7GX



P SERIES

Ød ₁	P	L ₁ js16	L ₂	L ₃	Ød ₂ h9	a h12	Z		P80 V-MAXX ...0808A1AV0	P80 6GX V-MAXX ...0808A1CV0	P80 7GX V-MAXX ...0808A1DV0
[mm]	[mm]	[mm]	[mm]	[mm]	[mm]	[mm]	[-]	[mm]			
M2	0,4	45	7	11	2,8	2,1	3	1,85	A00020...	A00020...	
2,5	0,45	50	9	15	2,8	2,1	3	2,3	A00025...	A00025...	
3	0,5	56	10	18	3,5	2,7	4	2,8	A00030...	A00030...	A00030...
3,5	0,6	56	11	20	4	3	4	3,25	A00035...	A00035...	A00035...
4	0,7	63	12	21	4,5	3,4	5	3,7	A00040...	A00040...	A00040...
5	0,8	70	14	24,5	6	4,9	5	4,65	A00050...	A00050...	A00050...
6	1	80	16	29	6	4,9	5	5,55	A00060...	A00060...	A00060...
8	1,25	90	18	33	8	6,2	5	7,4	A00080...	A00080...	A00080...
10	1,5	100	20	36	10	8	5	9,3	A00100...	A00100...	A00100...
12	1,75	110	24	-	9	7	5	11,2	A00120...	A00120...	A00120...
14	2	110	25	-	11	9	6	13,1	A00140...	A00140...	A00140...
16	2	110	28	-	12	9	6	15,1	A00160...	A00160...	A00160...



NEW
P80 N
V-MAXX

NEW
P80 N 6GX
V-MAXX

NEW
P80 N 7GX
V-MAXX

DIN 2174 (371)
≤ M10

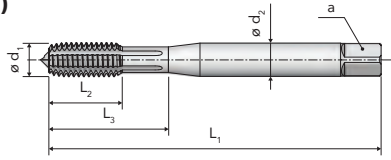

DIN 2174 (376)
≥ M12

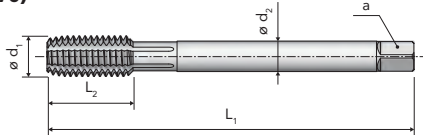

APPLICATION RANGE - CUTTING SPEED m/min

ISO	MG	P80 N V-MAXX	P80 N 6GX V-MAXX	P80 N 7GX V-MAXX
P	P.1-2	● 20-25	● 20-25	● 20-25
	P.3	● 15-20	● 15-20	● 15-20
N	N.1-2	● 20-25	● 20-25	● 20-25
	N.3	● 15-20	● 15-20	● 15-20
	N.5-6	● 20-25	● 20-25	● 20-25



Ød ₁	P	L ₁ js 16	L ₂	L ₃	Ød ₂ h9	a h12	Z		P80 N V-MAXX ...0808G1AV0	P80 N 6GX V-MAXX ...0808G1CVO	P80 N 7GX V-MAXX ...0808G1DVO
[mm]	[mm]	[mm]	[mm]	[mm]	[mm]	[mm]	[-]	[mm]			
M 2	0,4	45	7	11	2,8	2,1	3	1,85	A00020...	A00020...	
2,5	0,45	50	9	15	2,8	2,1	3	2,3	A00025...	A00025...	
3	0,5	56	10	18	3,5	2,7	4	2,8	A00030...	A00030...	A00030...
3,5	0,6	56	11	20	4	3	4	3,25	A00035...	A00035...	A00035...
4	0,7	63	12	21	4,5	3,4	5	3,7	A00040...	A00040...	A00040...
5	0,8	70	14	24,5	6	4,9	5	4,65	A00050...	A00050...	A00050...
6	1	80	16	29	6	4,9	5	5,55	A00060...	A00060...	A00060...
8	1,25	90	18	33	8	6,2	5	7,4	A00080...	A00080...	A00080...
10	1,5	100	20	36	10	8	5	9,3	A00100...	A00100...	A00100...
12	1,75	110	24	-	9	7	5	11,2	A00120...	A00120...	A00120...
14	2	110	25	-	11	9	6	13,1	A00140...	A00140...	A00140...
16	2	110	28	-	12	9	6	15,1	A00160...	A00160...	A00160...
18	2,5	125	28	-	14	11	8	16,9	A00180...		
20	2,5	140	30	-	16	12	8	18,9	A00200...		



NEW
P80 E
V-MAXX

NEW
P80 NE
V-MAXX

NEW
P80 NE 6GX
V-MAXX

DIN 2174 (371)
≤ M10

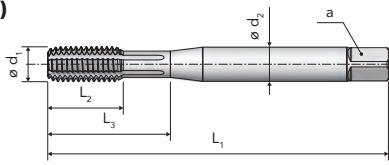

DIN 2174 (376)
≥ M12

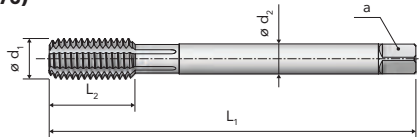

APPLICATION RANGE - CUTTING SPEED m/min

ISO	MG	P80 E V-MAXX	P80 NE V-MAXX	P80 NE 6GX V-MAXX
P	P.1-2	• 20-25	• 20-25	• 20-25
	P.3	• 15-20	• 15-20	• 15-20
N	N.1-2	• 20-25	• 20-25	• 20-25
	N.3	• 15-20	• 15-20	• 15-20
	N.5-6	• 20-25	• 20-25	• 20-25



P SERIES

$\varnothing d_1$	P	L_1 js16	L_2	L_3	$\varnothing d_2$ h9	a h12	Z		P80 E V-MAXX ...0808A3AV0	P80 NE V-MAXX ...0808G3AV0	P80 NE 6GX V-MAXX ...0808G3CVO
[mm]	[mm]	[mm]	[mm]	[mm]	[mm]	[mm]	[-]	[mm]			
M 3	0,5	56	10	18	3,5	2,7	4	2,8	A00030..	A00030..	A00030..
3,5	0,6	56	11	20	4	3	4	3,25		A00035..	
4	0,7	63	12	21	4,5	3,4	5	3,7	A00040...	A00040...	A00040...
5	0,8	70	14	24,5	6	4,9	5	4,65	A00050...	A00050...	A00050...
6	1	80	16	29	6	4,9	5	5,55	A00060...	A00060...	A00060...
8	1,25	90	18	33	8	6,2	5	7,4	A00080...	A00080...	A00080...
10	1,5	100	20	36	10	8	5	9,3	A00100...	A00100...	A00100...
12	1,75	110	24	-	9	7	5	11,2		A00120...	
16	2	110	28	-	12	9	6	15,1		A00160...	



NEW
BP80 N R
V-MAXX

NEW
BP80 NE
V-MAXX

DIN 2174 (371)
≤ M10

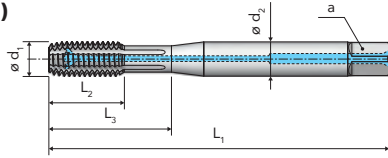

DIN 2174 (376)
≥ M12

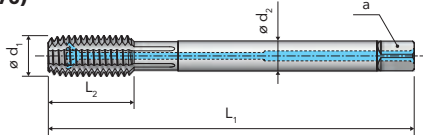

APPLICATION RANGE - CUTTING SPEED m/min

ISO	MG	BP80 N R V-MAXX	BP80 NE V-MAXX
P	P.1-2	• 20-25	• 20-25
	P.3	• 15-20	• 15-20
N	N.1-2	• 20-25	• 20-25
	N.3	• 15-20	• 15-20
	N.5-6	• 20-25	• 20-25

$\varnothing d_1$	P	L_1 js 16	L_2	L_3	$\varnothing d_2$ h9	a h12	Z		BP80 N R V-MAXX ...0808R1AVO	BP80 NE V-MAXX ...0808Q3AVO
[mm]	[mm]	[mm]	[mm]	[mm]	[mm]	[mm]	[-]	[mm]		
M 5	0,8	70	14	24,5	6	4,9	5	4,65	A00050...	A00050...
6	1	80	16	29	6	4,9	5	5,55	A00060...	A00060...
8	1,25	90	18	33	8	6,2	5	7,4	A00080...	A00080...
10	1,5	100	20	36	10	8	5	9,3	A00100...	A00100...
12	1,75	110	24	-	9	7	5	11,2	A00120...	A00120...
16	2	110	28	-	12	9	6	15,1	A00160...	A00160...
20	2,5	140	30	-	16	12	8	18,9	A00200...	



NEW
P900 N
V-MAXX

P900 N
RED-MAXX

P900 N 6GX
RED-MAXX

P900 N 7GX
RED-MAXX

DIN 2174 (371)
≤ M10

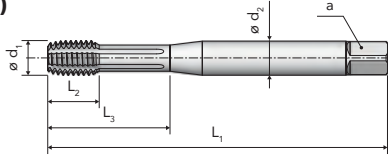

DIN 2174 (376)
≥ M12

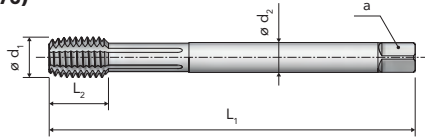

P SERIES

APPLICATION RANGE - CUTTING SPEED m/min

ISO	MG	P900 N V-MAXX	P900 N RED-MAXX	P900 N 6GX RED-MAXX	P900 N 7GX RED-MAXX
P	P.1-2	● 40-45	● 40-45	● 40-45	● 40-45
	P.3	● 35-40	● 35-40	● 35-40	● 35-40
	P.4	● 30-35	● 30-35	● 30-35	● 30-35
	P.5	● 15-20	● 15-20	● 15-20	● 15-20
	P.7	● 10-15			
M	M.1	● 10-15			
N	N.1-2	● 40-45	● 40-45	● 40-45	● 40-45
	N.3	● 35-40	● 35-40	● 35-40	● 35-40
	N.5-6	● 40-45	● 40-45	● 40-45	● 40-45
S	S.3	● 10-15	● 10-15	● 10-15	● 10-15



$\varnothing d_1$	P	L_1 js16	L_2	L_3	$\varnothing d_2$ h9	a h12	z		$\varnothing d_1$	$\varnothing d_2$	$\varnothing d_3$	$\varnothing d_4$
[mm]	[mm]	[mm]	[mm]	[mm]	[mm]	[mm]	[-]	[mm]	[mm]	[mm]	[mm]	[mm]
M2	0,4	45	4	11	2,8	2,1	3	1,85	P900 N V-MAXX ...9008G1AV0	P900 N RED-MAXX ...9008G1AR0	P900 N 6GX RED-MAXX ...9008G1CR0	P900 N 7GX RED-MAXX ...9008G1DR0
2,5	0,45	50	4,5	14	2,8	2,1	4	2,3	A00025...	A00025...		
3	0,5	56	5	17	3,5	2,7	4	2,8	A00030...	A00030...	A00030...	A00030...
3,5	0,6	56	6	19	4	3	4	3,25	A00035...	A00035...		
4	0,7	63	7	21	4,5	3,4	5	3,7	A00040...	A00040...	A00040...	A00040...
5	0,8	70	8	25	6	4,9	5	4,65	A00050...	A00050...	A00050...	A00050...
6	1	80	10	29	6	4,9	5	5,6	A00060...	A00060...	A00060...	A00060...
7	1	80	10	29	7	5,5	5	6,6	A00070...	A00070...		
8	1,25	90	13	35	8	6,2	5	7,45	A00080...	A00080...	A00080...	A00080...
10	1,5	100	15	39	10	8	6	9,35	A00100...	A00100...	A00100...	A00100...
12	1,75	110	18	-	9	7	8	11,25	A00120...	A00120...	A00120...	A00120...
14	2	110	20	-	11	9	8	13,1	A00140...	A00140...		
16	2	110	20	-	12	9	8	15,1	A00160...	A00160...	A00160...	
20	2,5	140	25	-	16	12	8	18,9	A00200...	A00200...	A00200...	



HSSZ



NEW
P900 NE
V-MAXX

P900 NE
RED-MAXX

P900 NE 6GX
RED-MAXX

DIN 2174 (371)
≤ M10

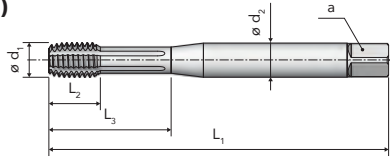

DIN 2174 (376)
≥ M12

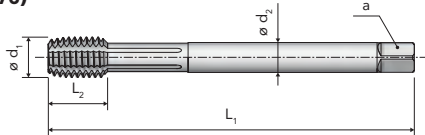

APPLICATION RANGE - CUTTING SPEED m/min

ISO	MG	P900 NE V-MAXX	P900 NE RED-MAXX	P900 NE 6GX RED-MAXX
P	P.1-2	● 40-45	● 40-45	● 40-45
	P.3	● 35-40	● 35-40	● 35-40
	P.4	● 30-35	● 30-35	● 30-35
	P.5	● 15-20	● 15-20	● 15-20
	P.7	● 10-15		
M	M.1	● 10-15		
N	N.1-2	● 40-45	● 40-45	● 40-45
	N.3	● 35-40	● 35-40	● 35-40
	N.5-6	● 40-45	● 40-45	● 40-45
S	S.3	● 10-15	● 10-15	● 10-15



$\varnothing d_1$	P	L_1 js 16	L_2	L_3	$\varnothing d_2$ h9	a h12	Z		P900 NE V-MAXX ...9008G3AV0	P900 NE RED-MAXX ...9008G3ARO	P900 NE 6GX RED-MAXX ...9008G3CRO
[mm]	[mm]	[mm]	[mm]	[mm]	[mm]	[mm]	[-]	[mm]			
M 2	0,4	45	4	11	2,8	2,1	3	1,85	A00020...	A00020...	
2,5	0,45	50	4,5	14	2,8	2,1	4	2,3	A00025...	A00025...	
3	0,5	56	5	17	3,5	2,7	4	2,8	A00030...	A00030...	A00030...
3,5	0,6	56	6	19	4	3	4	3,25	A00035...	A00035...	
4	0,7	63	7	21	4,5	3,4	5	3,7	A00040...	A00040...	A00040...
5	0,8	70	8	25	6	4,9	5	4,65	A00050...	A00050...	A00050...
6	1	80	10	29	6	4,9	5	5,6	A00060...	A00060...	A00060...
8	1,25	90	13	35	8	6,2	5	7,45	A00080...	A00080...	A00080...
10	1,5	100	15	39	10	8	6	9,35	A00100...	A00100...	A00100...
12	1,75	110	18	-	9	7	8	11,25	A00120...	A00120...	A00120...
16	2	110	20	-	12	9	8	15,1	A00160...	A00160...	A00160...
20	2,5	140	25	-	16	12	8	18,9	A00200...	A00200...	A00200...



BP900 N R RED-MAXX **BP900 N RE** RED-MAXX **BP900 N** RED-MAXX **NEW BP900 NE** RED-MAXX

DIN 2174 (371)
≤ M10

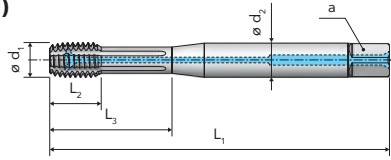

DIN 2174 (376)
≥ M12

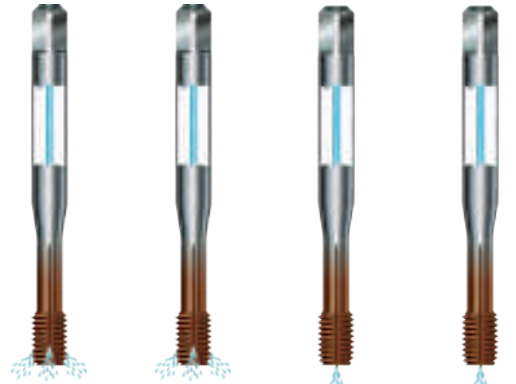
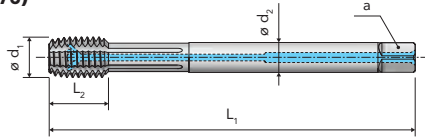

P SERIES

APPLICATION RANGE - CUTTING SPEED m/min

ISO	MG	BP900 N R RED-MAXX	BP900 N RE RED-MAXX	BP900 N RED-MAXX	BP900 NE RED-MAXX
P	P.1-2	● 40-45	● 40-45	● 40-45	● 40-45
	P.3	● 35-40	● 35-40	● 35-40	● 35-40
	P.4	● 30-35	● 30-35	● 30-35	● 30-35
	P.5	● 15-20	● 15-20	● 15-20	● 15-20
N	N.1-2	● 40-45	● 40-45	● 40-45	● 40-45
	N.3	● 35-40	● 35-40	● 35-40	● 35-40
	N.5-6	● 40-45	● 40-45	● 40-45	● 40-45
S	S.3	● 10-15	● 10-15	● 10-15	● 10-15

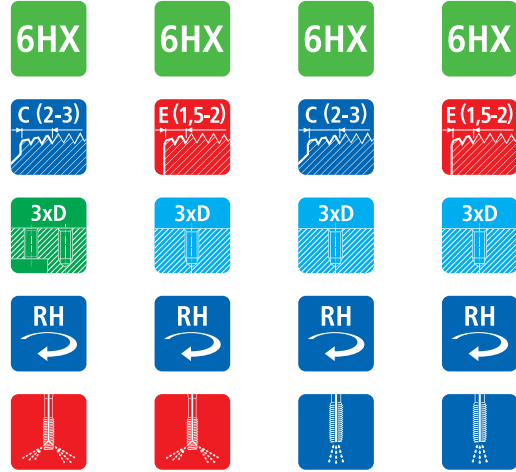

$\varnothing d_1$	P	L_1 js16	L_2	L_3	$\varnothing d_2$ h9	a h12	z		BP900 N R RED-MAXX ...9008R1ARO	BP900 N RE RED-MAXX ...9008R3ARO	BP900 N RED-MAXX ...9008Q1ARO	BP900 NE RED-MAXX ...9008Q3ARO
[mm]	[mm]	[mm]	[mm]	[mm]	[mm]	[mm]	[-]	[mm]				
M 5	0,8	70	8	25	6	4,9	5	4,65	A00050...	A00050...	A00050...	A00050...
6	1	80	10	29	6	4,9	5	5,6	A00060...	A00060...	A00060...	A00060...
8	1,25	90	13	35	8	6,2	5	7,45	A00080...	A00080...	A00080...	A00080...
10	1,5	100	15	36	10	8	6	9,35	A00100...	A00100...	A00100...	A00100...
12	1,75	110	18	-	9	7	8	11,25	A00120...	A00120...	A00120...	A00120...
16	2	110	20	-	12	9	8	15,1	A00160...	A00160...	A00160...	A00160...
20	2,5	140	25	-	16	12	8	18,9	A00200...	A00200...	A00200...	A00200...
24	3	160	30	-	18	14,5	8	22,7	A00240...			
27	3	160	30	-	20	16	8	25,7	A00270...			
30	3,5	180	35	-	22	18	8	28,45	A00300...			



P900 N LH
RED-MAXX

DIN 2174 (371)
≤ M10

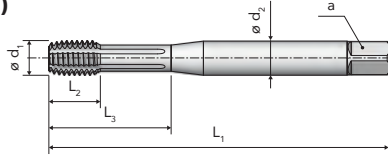

DIN 2174 (376)
≥ M12

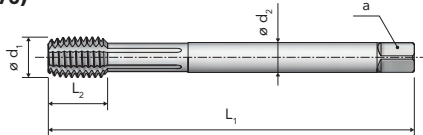

APPLICATION RANGE - CUTTING SPEED m/min

ISO	MG	P900 N LH RED-MAXX			
P	P.1-2	● 40-45			
	P.3	● 35-40			
	P.4	● 30-35			
	P.5	● 15-20			
N	N.1-2	● 40-45			
	N.3	● 35-40			
	N.5-6	● 40-45			
S	S.3	● 10-15			



$\varnothing d_1$	P	L_1 js 16	L_2	L_3	$\varnothing d_2$ h9	a h12	Z		P900 N LH RED-MAXX ...9008S1AR0
[mm]	[mm]	[mm]	[mm]	[mm]	[mm]	[mm]	[-]	[mm]	
M 2	0,4	45	4	11	2,8	2,1	3	1,85	A00020...
3	0,5	56	5	17	3,5	2,7	4	2,8	A00030...
4	0,7	63	7	21	4,5	3,4	5	3,7	A00040...
5	0,8	70	8	25	6	4,9	5	4,65	A00050...
6	1	80	10	29	6	4,9	5	5,6	A00060...
8	1,25	90	13	35	8	6,2	5	7,45	A00080...
10	1,5	100	15	39	10	8	6	9,35	A00100...
12	1,75	110	18	-	9	7	8	11,25	A00120...
16	2	110	20	-	12	9	8	15,1	A00160...



P900 N L
RED-MAXX

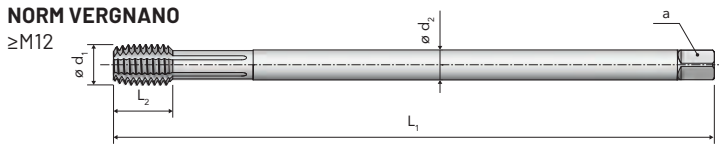
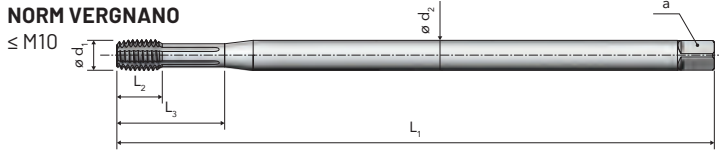

P SERIES

APPLICATION RANGE - CUTTING SPEED m/min

ISO	MG	P900 N L RED-MAXX			
P	P.1-2	• 40-45			
	P.3	• 35-40			
	P.4	• 30-35			
	P.5	• 15-20			
N	N.1-2	• 40-45			
	N.3	• 35-40			
	N.5-6	• 40-45			
S	S.3	• 10-15			



$\varnothing d_1$	P	L_1 js16	L_2	L_3	$\varnothing d_2$ h9	a h12	Z		P900 N L RED-MAXX ...9008L1AR0
[mm]	[mm]	[mm]	[mm]	[mm]	[mm]	[mm]	[-]	[mm]	
M 3	0,5	112	5	17	3,5	2,7	4	2,8	A00030...
4	0,7	126	7	21	4,5	3,4	5	3,7	A00040...
5	0,8	140	8	25	6	4,9	5	4,65	A00050...
6	1	160	10	29	6	4,9	5	5,6	A00060...
8	1,25	180	13	35	8	6,2	5	7,45	A00080...
10	1,5	200	15	39	10	8	6	9,35	A00100...
12	1,75	220	18	-	9	7	8	11,25	A00120...
16	2	220	20	-	12	9	8	15,1	A00160..



P45
V-MAXX

BP45
V-MAXX

P45 E
V-MAXX

BP45 E
V-MAXX

DIN 374

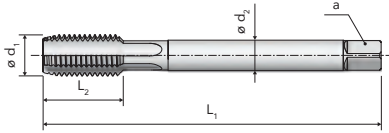

P SERIES



APPLICATION RANGE - CUTTING SPEED m/min

ISO	MG	P45 V-MAXX	BP45 V-MAXX	P45 E V-MAXX	BP45 E V-MAXX
K	K.1	● 40-50	● 40-50	● 40-50	● 40-50
	N.4	● 40-50	● 40-50	● 40-50	● 40-50
N	N.7	● 40-50	● 40-50	● 40-50	● 40-50
	N.9-10	● 45-55	● 45-55	● 45-55	● 45-55



Ød ₁	P	L ₁ js 16	L ₂	L ₃	Ød ₂ h9	a h12	Z		P45 V-MAXX ...0455A1AV0	BP45 V-MAXX ...0455M1AV0	P45 E V-MAXX ...0455A3AV0	BP45 E V-MAXX ...0455M3AV0
[mm]	[mm]	[mm]	[mm]	[mm]	[mm]	[mm]	[-]	[mm]				
M 8	1	90	16	-	6	4,9	4	7	A08100...	A08100...	A08100...	A08100...
10	1	90	18	-	7	5,5	4	9	A10100...	A10100...	A10100...	A10100...
10	1,25	100	18	-	7	5,5	4	8,8	A10125...	A10125...	A10125...	A10125...
12	1,25	100	22	-	9	7	4	10,8	A12125...	A12125...	A12125...	A12125...
12	1,5	100	22	-	9	7	4	10,5	A12150...	A12150...	A12150...	A12150...
14	1,25	100	22	-	11	9	4	12,8	A14125...	A14125...		
14	1,5	100	22	-	11	9	4	12,5	A14150...	A14150...	A14150...	A14150...
16	1,5	100	22	-	12	9	4	14,5	A16150...	A16150...	A16150...	A16150...
20	1,5	125	25	-	16	12	4	18,5	A20150...	A20150...		

HIGH PERFORMANCE MACHINE TAPS for through holes
Straight flutes with spiral point



P17
TiN

P17
TiH1

P17 6GX
TiH1

BP17
TiH1

DIN 374

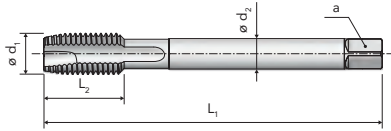

P SERIES

APPLICATION RANGE - CUTTING SPEED m/min

ISO	MG	P17 TiN	P17 TiH1	P17 6GX TiH1	BP17 TiH1
P	P.3	• 25-35	• 25-35	• 25-35	• 25-35
	P.4	• 20-30	• 20-30	• 20-30	• 20-30
	P.5	• 10-20	• 10-20	• 10-20	• 10-20
	P.6	• 8-10	• 8-10	• 8-10	• 8-10
	P.7	• 10-15	• 10-15	• 10-15	• 10-15
M	M.1	• 10-15	• 10-15	• 10-15	• 10-15
	M.2	• 6-8	• 6-8	• 6-8	• 6-8
K	K.2	• 25-35	• 25-35	• 25-35	• 25-35
N	N.2-3	• 30-40	• 30-40	• 30-40	• 30-40
	N.6	• 25-35	• 25-35	• 25-35	• 25-35



$\varnothing d_1$	P	L_1 js16 [mm]	L_2 [mm]	L_3 [mm]	$\varnothing d_2$ h9 [mm]	a h12 [mm]	z		P17 TiN ...0174A2ADO	P17 TiH1 ...0174A2AHO	P17 6GX TiH1 ...0174A2CHO	BP17 TiH1 ...0174M2AHO
[mm]	[mm]	[mm]	[mm]	[mm]	[mm]	[mm]	[-]	[mm]				
M 8	1	90	16	-	6	4,9	3	7	A08100...	A08100...	A08100...	A08100...
10	1	90	18	-	7	5,5	3	9	A10100...	A10100...	A10100...	A10100...
10	1,25	100	18	-	7	5,5	3	8,8	A10125...	A10125...	A10125...	A10125...
12	1	100	22	-	9	7	4	11	A12100...	A12100...	A12100...	A12100...
12	1,25	100	22	-	9	7	4	10,8	A12125...	A12125...	A12125...	A12125...
12	1,5	100	22	-	9	7	4	10,5	A12150...	A12150...	A12150...	A12150...
14	1,5	100	22	-	11	9	4	12,5	A14150...	A14150...	A14150...	A14150...
16	1,5	100	22	-	12	9	4	14,5	A16150...	A16150...	A16150...	A16150...
18	1,5	110	25	-	14	11	4	16,5	A18150...	A18150...	A18150...	A18150...
20	1,5	125	25	-	16	12	4	18,5	A20150...	A20150...	A20150...	A20150...



NEW
P151
G-MAXX

DIN 374

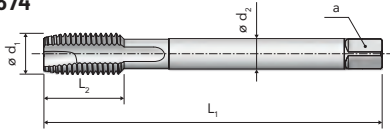

APPLICATION RANGE - CUTTING SPEED m/min

ISO	MG	P151 G-MAXX			
P	P.7	• 15-20			
M	M.1	• 15-20			
	M.2	• 10-12			



Ød ₁	P	L ₁ js 16	L ₂	L ₃	Ød ₂ h9	a h12	Z		P151 G-MAXX ...1515A2AX0
[mm]	[mm]	[mm]	[mm]	[mm]	[mm]	[mm]	[-]	[mm]	
M 8	1	90	16	-	6	4,9	3	7	A08100...
10	1	90	18	-	7	5,5	3	9	A10100...
10	1,25	100	18	-	7	5,5	3	8,8	A10125...
12	1,25	100	22	-	9	7	3	10,8	A12125...
12	1,5	100	22	-	9	7	3	10,5	A12150...
14	1,5	100	22	-	11	9	3	12,5	A14150...
16	1,5	100	22	-	12	9	3	14,5	A16150...
18	1,5	110	25	-	14	11	4	18,5	A18150...
20	1,5	125	25	-	16	12	4	18,5	A20150...



P30
BRIGHT

P30
TiN

P30
TiH1

BP30
TiH1

DIN 374

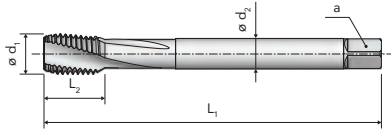

P SERIES

APPLICATION RANGE - CUTTING SPEED m/min

ISO	MG	P30 BRIGHT	P30 TiN	P30 TiH1	BP30 TiH1
P	P.3	• 15-18	• 25-30	• 25-30	• 25-30
	P.4	• 12-15	• 20-25	• 20-25	• 20-25
	P.5	• 8-10	• 10-15	• 10-15	• 10-15
	P.6	• 3-5	• 5-10	• 5-10	• 5-10
	P.7	• 8-10	• 10-15	• 10-15	• 10-15
K	K.2	• 15-18	• 25-30	• 25-30	• 25-30
N	N.3	• 15-18	• 25-30	• 25-30	• 25-30
	N.6	• 15-18	• 25-30	• 25-30	• 25-30
	N.7	• 12-15	• 20-25	• 20-25	• 20-25
S	S.2	• 2-3		• 2-3	• 2-3
	S.4	• 2-3	• 2-3	• 2-3	• 2-3

$\varnothing d_1$	P	L_1 js16	L_2	L_3	$\varnothing d_2$ h9	a h12	z		P30 BRIGHT ...0305A1AA0	P30 TiN ...0305A1AD0	P30 TiH1 ...0305A1AH0	BP30 TiH1 ...0305M1AH0
[mm]	[mm]	[mm]	[mm]	[mm]	[mm]	[mm]	[-]	[mm]				
M8	1	90	10	-	6	4,9	3	7	A08100...	A08100...	A08100...	
10	1	90	11	-	7	5,5	3	9	A10100...	A10100...	A10100...	
10	1,25	100	12	-	7	5,5	3	8,8	A10125...	A10125...	A10125...	A10125...
12	1,25	100	14	-	9	7	3	10,8	A12125...	A12125...	A12125...	A12125...
12	1,5	100	15	-	9	7	3	10,5	A12150...	A12150...	A12150...	A12150...
14	1,5	100	16	-	11	9	3	12,5	A14150...	A14150...	A14150...	A14150...
16	1,5	100	16	-	12	9	3	14,5	A16150...	A16150...	A16150...	A16150...
18	1,5	110	18	-	14	11	4	16,5	A18150...	A18150...	A18150...	A18150...
20	1,5	125	18	-	16	12	4	18,5	A20150...	A20150...	A20150...	A20150...



P30 E
TiH1

DIN 374

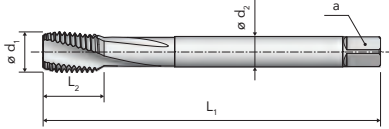

APPLICATION RANGE - CUTTING SPEED m/min

ISO	MG	P30 E TiH1			
P	P.3	• 25-30			
	P.4	• 20-25			
	P.5	• 10-15			
	P.6	• 5-10			
	P.7	• 10-15			
K	K.2	• 25-30			
N	N.3	• 25-30			
	N.6	• 25-30			
	N.7	• 20-25			
S	S.2	• 2-3			
	S.4	• 2-3			



Ød ₁	P	L ₁ js 16	L ₂	L ₃	Ød ₂ h9	a h12	Z		P30 E TiH1 ...0305A3AH0
[mm]	[mm]	[mm]	[mm]	[mm]	[mm]	[mm]	[-]	[mm]	
M 8	1	90	10	-	6	4,9	3	7	A08100...
10	1	90	11	-	7	5,5	3	9	A10100...
10	1,25	100	12	-	7	5,5	3	8,8	A10125...
12	1,25	100	14	-	9	7	3	10,8	A12125...
12	1,5	100	15	-	9	7	3	10,5	A12150...
14	1,5	100	16	-	11	9	3	12,5	A14150...
16	1,5	100	16	-	12	9	3	14,5	A16150...

HIGH PERFORMANCE MACHINE TAPS for blind holes
45° spiral flutes / back tapered



P71 TiN
P71 TiH1
P71 6GX TiH1
BP71 TiH1

DIN 374

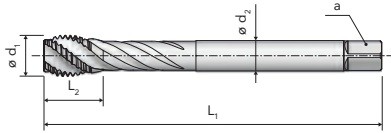

P SERIES

APPLICATION RANGE - CUTTING SPEED m/min

ISO	MG	P71 TiN	P71 TiH1	P71 6GX TiH1	BP71 TiH1
P	P.3	• 20-30	• 20-30	• 20-30	• 20-30
	P.4	• 15-25	• 15-25	• 15-25	• 15-25
	P.5	• 5-15	• 5-15	• 5-15	• 5-15
	P.7	• 8-10	• 8-10	• 8-10	• 8-10
M	M.1	• 8-10	• 8-10	• 8-10	• 8-10
	M.2	• 5-7	• 5-7	• 5-7	• 5-7
K	K.2	• 20-30	• 20-30	• 20-30	• 20-30
N	N.3	• 25-35	• 25-35	• 25-35	• 25-35
	N.6	• 25-35	• 25-35	• 25-35	• 25-35
S	S.1		• 10-15	• 10-15	• 10-15
	S.3	• 10-15	• 10-15	• 10-15	• 10-15

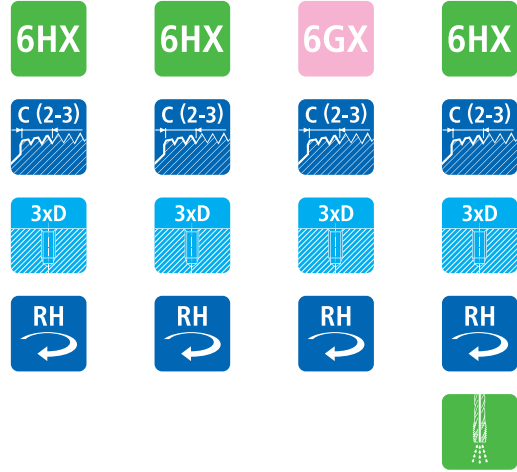

Ød ₁	P	L ₁ js16	L ₂	L ₃	Ød ₂ h9	a h12	z		P71 TiN ...0714A1ADO	P71 TiH1 ...0714A1AHO	P71 6GX TiH1 ...0714A1CHO	BP71 TiH1 ...0714M1AHO
[mm]	[mm]	[mm]	[mm]	[mm]	[mm]	[mm]	[-]	[mm]				
M 8	1	90	12	-	6	4,9	3	7	A08100...	A08100...	A08100...	A08100...
10	1	90	12	-	7	5,5	3	9	A10100...	A10100...	A10100...	A10100...
10	1,25	100	14	-	7	5,5	3	8,8	A10125...	A10125...	A10125...	A10125...
12	1	100	14	-	9	7	4	11	A12100...	A12100...	A12100...	
12	1,25	100	14	-	9	7	4	10,8	A12125...	A12125...	A12125...	A12125...
12	1,5	100	15	-	9	7	4	10,5	A12150...	A12150...	A12150...	A12150...
14	1,5	100	16	-	11	9	4	12,5	A14150...	A14150...	A14150...	A14150...
16	1,5	100	16	-	12	9	4	14,5	A16150...	A16150...	A16150...	A16150...
18	1,5	110	18	-	14	11	4	16,5	A18150...	A18150...	A18150...	A18150...
20	1,5	125	18	-	16	12	4	18,5	A20150...	A20150...	A20150...	A20150...
22	1,5	125	19	-	18	14,5	4	20,5		A22150...		
24	1,5	140	19	-	18	14,5	4	22,5		A24150...		
27	1,5	140	21	-	20	16	5	25,5		A27150...		
30	1,5	150	22	-	22	18	5	28,5		A30150...		



P71 E
TiH1

NEW
P71 E 6GX
TiH1

DIN 374

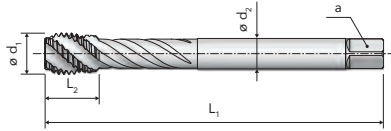

APPLICATION RANGE - CUTTING SPEED m/min

ISO	MG	P71 E TiH1	P71 E 6GX TiH1
P	P.3	• 20-30	• 20-30
	P.4	• 15-25	• 15-25
	P.5	• 5-15	• 5-15
	P.7	• 8-10	• 8-10
M	M.1	• 8-10	• 8-10
	M.2	• 5-7	• 5-7
K	K.2	• 20-30	• 20-30
N	N.3	• 25-35	• 25-35
	N.6	• 25-35	• 25-35
S	S.1	• 10-15	• 10-15
	S.3	• 10-15	• 10-15



Ød ₁	P	L ₁ js 16	L ₂	L ₃	Ød ₂ h9	a h12	Z		P71 E TiH1 ...0714A3AH0	P71 E 6GX TiH1 ...0714A3CH0
[mm]	[mm]	[mm]	[mm]	[mm]	[mm]	[mm]	[-]	[mm]		
M 8	1	90	12	-	6	4,9	4	7	A08100...	A08100...
10	1	90	12	-	7	5,5	4	9	A10100...	A10100...
10	1,25	100	14	-	7	5,5	4	8,8	A10125...	A10125...
12	1	100	14	-	9	7	4	11	A12100...	A12100...
12	1,25	100	14	-	9	7	4	10,8	A12125...	A12125...
12	1,5	100	15	-	9	7	4	10,5	A12150...	A12150...
14	1,5	100	16	-	11	9	5	12,5	A14150...	A14150...
16	1,5	100	16	-	12	9	5	14,5	A16150...	A16150...

HIGH PERFORMANCE MACHINE TAPS for blind holes
45° spiral flutes / back tapered / for stainless steel



NEW
P171
G-MAXX

DIN 374

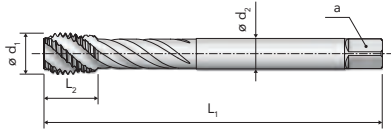

P SERIES

APPLICATION RANGE - CUTTING SPEED m/min

ISO	MG	P171 G-MAXX			
P	P.7	• 10-15			
M	M.1	• 10-15			
	M.2	• 6-8			



Ød ₁	P	L ₁ js16	L ₂	L ₃	Ød ₂ h9	a h12	Z		P171 G-MAXX ...1714A1AX0
[mm]	[mm]	[mm]	[mm]	[mm]	[mm]	[mm]	[-]	[mm]	
M 8	1	90	12	-	6	4,9	3	7	A08100...
10	1	90	12	-	7	5,5	3	9	A10100...
10	1,25	100	14	-	7	5,5	3	8,8	A10125...
12	1	100	14	-	9	7	4	11	A12100...
12	1,25	100	14	-	9	7	4	10,8	A12125...
12	1,5	100	15	-	9	7	4	10,5	A12150...
14	1,5	100	16	-	11	9	4	12,5	A14150...
16	1,5	100	16	-	12	9	4	14,5	A16150...
18	1,5	110	18	-	14	11	4	16,5	A18150...
20	1,5	125	18	-	16	12	4	18,5	A20150...



NEW
P81
V-MAXX

NEW
P81 6GX
V-MAXX

DIN 2174 (371)
≤ M10x1,25

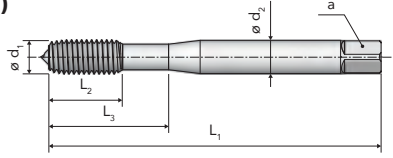

DIN 2174 (374)
≥ M12x1

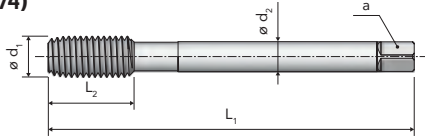

APPLICATION RANGE - CUTTING SPEED m/min

ISO	MG	P81 V-MAXX	P81 6GX V-MAXX
P	P.1-2	● 20-25	● 20-25
	P.3	● 15-20	● 15-20
N	N.1-2	● 20-25	● 20-25
	N.3	● 15-20	● 15-20
	N.5-6	● 20-25	● 20-25

6HX

6GX



Ød ₁	P	L ₁ js 16	L ₂	L ₃	Ød ₂ h9	a h12	Z		P81 V-MAXX ...0818A1AV0	P81 6GX V-MAXX ...0818A1CV0
[mm]	[mm]	[mm]	[mm]	[mm]	[mm]	[mm]	[-]	[mm]		
M 4	0,5	63	12	21	4,5	3,4	5	3,8	A04050...	A04050...
5	0,5	70	14	24,5	6	4,9	5	4,8	A05050...	A05050...
6	0,75	80	16	29	6	4,9	5	5,65	A06075...	A06075...
8	1	90	18	33	8	6,2	5	7,55	A08100...	A08100...
10	1	90	18	34	10	8	6	9,55	A10100...	A10100...
10	1,25	100	20	36	10	8	6	9,4	A10125...	A10125...
12	1	100	22	-	9	7	6	11,55	A12100...	A12100...
12	1,25	100	22	-	9	7	6	11,4	A12125...	A12125...
12	1,5	100	22	-	9	7	6	11,3	A12150...	A12150...
14	1,25	100	22	-	11	9	6	13,4	A14125...	A14125...
14	1,5	100	22	-	11	9	6	13,3	A14150...	A14150...
16	1,5	100	22	-	12	9	6	15,3	A16150...	A16150...

HIGH PERFORMANCE COLD FORMING TAPS for blind and through holes
With oil grooves



NEW
P81 N
V-MAXX

NEW
P81 N 6GX
V-MAXX

DIN 2174 (371)
≤ M10x1,25

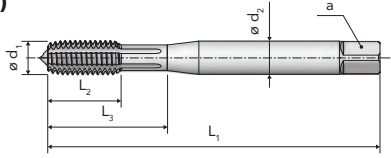

DIN 2174 (374)
≥ M12x1

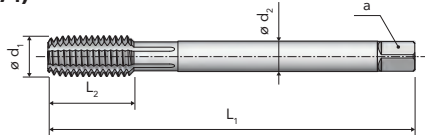

P SERIES

APPLICATION RANGE - CUTTING SPEED m/min

ISO	MG	P81 N V-MAXX	P81 N 6GX V-MAXX
P	P.1-2	• 20-25	• 20-25
	P.3	• 15-20	• 15-20
N	N.1-2	• 20-25	• 20-25
	N.3	• 15-20	• 15-20
	N.5-6	• 20-25	• 20-25



Ød ₁	P	L ₁ js16	L ₂	L ₃	Ød ₂ h9	a h12	Z		P81 N V-MAXX ...0818G1AV0	P81 N 6GX V-MAXX ...0818G1CV0
[mm]	[mm]	[mm]	[mm]	[mm]	[mm]	[mm]	[-]	[mm]		
M 4	0,5	63	12	21	4,5	3,4	5	3,8	A04050...	A04050...
5	0,5	70	14	24,5	6	4,9	5	4,8	A05050...	A05050...
6	0,75	80	16	29	6	4,9	5	5,65	A06075...	A06075...
8	1	90	18	33	8	6,2	5	7,55	A08100...	A08100...
10	1	90	18	34	10	8	6	9,55	A10100...	A10100...
10	1,25	100	20	36	10	8	6	9,4	A10125...	A10125...
12	1	100	22	-	9	7	6	11,55	A12100...	
12	1,25	100	22	-	9	7	6	11,4	A12125...	A12125...
12	1,5	100	22	-	9	7	6	11,3	A12150...	A12150...
14	1,25	100	22	-	11	9	6	13,4	A14125...	
14	1,5	100	22	-	11	9	6	13,3	A14150...	A14150...
16	1,5	100	22	-	12	9	6	15,3	A16150...	A16150...
18	1,5	110	22	-	14	11	8	17,3	A18150...	
20	1,5	125	25	-	16	12	8	19,3	A20150...	



NEW
P901 N
V-MAXX

P901 N
RED-MAXX

P901 N 6GX
RED-MAXX

DIN 2174 (371)
≤ M10x1

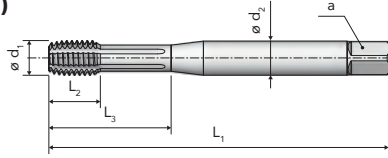

DIN 2174 (376)
≥ M12x1

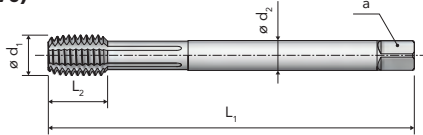

APPLICATION RANGE - CUTTING SPEED m/min

ISO	MG	P901 N V-MAXX	P901 N RED-MAXX	P901 N 6GX RED-MAXX
P	P.1-2	● 40-45	● 40-45	● 40-45
	P.3	● 35-40	● 35-40	● 35-40
	P.4	● 30-35	● 30-35	● 30-35
	P.5	● 15-20	● 15-20	● 15-20
	P.7	● 10-15		
M	M.1	● 10-15		
N	N.1-2	● 40-45	● 40-45	● 40-45
	N.3	● 35-40	● 35-40	● 35-40
	N.5-6	● 40-45	● 40-45	● 40-45
S	S.3	● 10-15	● 10-15	● 10-15



Ød ₁	P	L ₁ js 16	L ₂	L ₃	Ød ₂ h9	a h12	Z		P901 N V-MAXX ...9018G1AV0	P901 N RED-MAXX ...9018G1AR0	P901 N 6GX RED-MAXX ...9018G1CR0
[mm]	[mm]	[mm]	[mm]	[mm]	[mm]	[mm]	[-]	[mm]			
M 4	0,5	63	7	21	4,5	3,4	5	3,8	A04050...	A04050...	A04050...
5	0,5	70	8	25	6	4,9	5	4,8	A05050...	A05050...	A05050...
6	0,75	80	10	29	6	4,9	5	5,65	A06075...	A06075...	A06075...
8	1	90	13	35	8	6,2	5	7,55	A08100...	A08100...	A08100...
10	1	90	13	39	10	8	6	9,55	A10100...	A10100...	A10100...
12	1	100	13	-	9	7	8	11,55	A12100...	A12100...	A12100...
12	1,25	100	13	-	9	7	8	11,4	A12125...	A12125...	A12125...
12	1,5	100	15	-	9	7	8	11,3	A12150...	A12150...	A12150...
14	1,5	100	15	-	11	9	8	13,3	A14150...	A14150...	A14150...
16	1,5	100	15	-	12	9	8	15,3	A16150...	A16150...	A16150...
18	1,5	110	15	-	14	11	8	17,3	A18150...	A18150...	A18150...
20	1,5	125	15	-	16	12	8	19,3	A20150...	A20150...	A20150...

HIGH PERFORMANCE MACHINE TAPS for blind holes
With oil grooves / chamfer form E



NEW
P901 NE
V-MAXX

P901 NE
RED-MAXX

NEW
P901 NE 6GX
RED-MAXX

DIN 2174 (371)
≤ M10x1

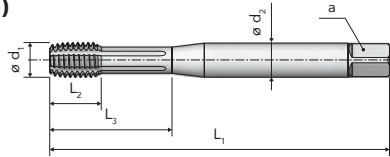

DIN 2174 (376)
≥ M12x1

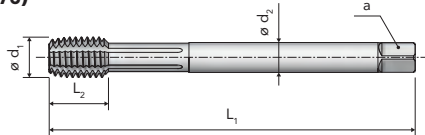

P SERIES

APPLICATION RANGE - CUTTING SPEED m/min

ISO	MG	P901 NE V-MAXX	P901 NE RED-MAXX	P901 NE 6GX RED-MAXX
P	P.1-2	● 40-45	● 40-45	● 40-45
	P.3	● 35-40	● 35-40	● 35-40
	P.4	● 30-35	● 30-35	● 30-35
	P.5	● 15-20	● 15-20	● 15-20
	P.7	● 10-15		
M	M.1	● 10-15		
N	N.1-2	● 40-45	● 40-45	● 40-45
	N.3	● 35-40	● 35-40	● 35-40
	N.5-6	● 40-45	● 40-45	● 40-45
S	S.3	● 10-15	● 10-15	● 10-15



$\varnothing d_1$	P	L_1 js16	L_2	L_3	$\varnothing d_2$ h9	a h12	Z		P901 NE V-MAXX ...9018G3AVO	P901 NE RED-MAXX ...9018G3ARO	P901 NE 6GX RED-MAXX ...9018G3CRO
[mm]	[mm]	[mm]	[mm]	[mm]	[mm]	[mm]	[-]	[mm]			
M 8	1	90	13	35	8	6,2	5	7,55	A08100...	A08100...	A08100...
10	1	90	13	39	10	8	6	9,55	A10100...	A10100...	A10100...
12	1	100	13	-	9	7	8	11,55	A12100...	A12100...	A12100...
12	1,25	100	13	-	9	7	8	11,45	A12125...	A12125...	A12125...
12	1,5	100	15	-	9	7	8	11,3	A12150...	A12150...	A12150...
14	1,5	100	15	-	11	9	8	13,3	A14150...	A14150...	A14150...
16	1,5	100	15	-	12	9	8	15,3	A16150...	A16150...	A16150...



BP901 N R
RED-MAXX

DIN 2174 (371)
≤ M10x1

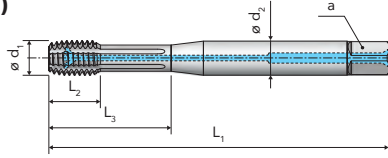

DIN 2174 (376)
≥ M12x1

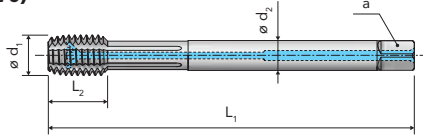

APPLICATION RANGE - CUTTING SPEED m/min

ISO	MG	BP901 N R RED-MAXX			
P	P.1-2	● 40-45			
	P.3	● 35-40			
	P.4	● 30-35			
	P.5	● 15-20			
N	N.1-2	● 40-45			
	N.3	● 35-40			
	N.5-6	● 40-45			
S	S.3	● 10-15			



$\varnothing d_1$	P	L_1 js 16	L_2	L_3	$\varnothing d_2$ h9	a h12	Z		BP901 N R RED-MAXX ...9018R1AR0
[mm]	[mm]	[mm]	[mm]	[mm]	[mm]	[mm]	[-]	[mm]	
M 5	0,5	70	8	25	6	4,9	5	4,8	A05050...
6	0,75	80	10	29	6	4,9	5	5,65	A06075...
8	1	90	13	35	8	6,2	5	7,55	A08100...
10	1	90	13	39	10	8	6	9,55	A10100...
12	1	100	13	-	9	7	8	11,55	A12100...
12	1,25	100	13	-	9	7	8	11,45	A12125...
12	1,5	100	15	-	9	7	8	11,3	A12150...
14	1,5	100	15	-	11	9	8	13,3	A14150...
16	1,5	100	15	-	12	9	8	15,3	A16150...

HIGH PERFORMANCE MACHINE TAPS for through holes
Straight flutes with spiral point



NEW
P19
TiH1

DIN 2184-1
≤ Ø1/4

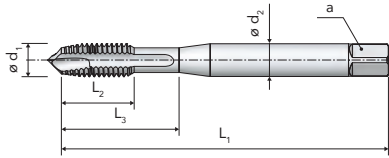

DIN 2184-1
≥ Ø5/16

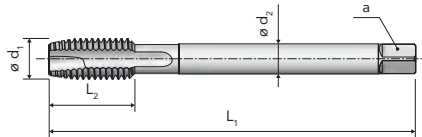

P SERIES

APPLICATION RANGE - CUTTING SPEED m/min

ISO	MG	P19 TiH1			
P	P.3	• 25-35			
	P.4	• 20-30			
	P.5	• 10-20			
	P.6	• 8-10			
	P.7	• 10-15			
M	M.1	• 10-15			
	M.2	• 6-8			
K	K.2	• 25-35			
N	N.2-3	• 30-40			
	N.6	• 25-35			



UNC	P	Ød ₁	L ₁ js16	L ₂	L ₃	Ød ₂ h9	a h12	z		P19 TiH1 ...0195A2MH0
	[TPI]	[mm]	[mm]	[mm]	[mm]	[mm]	[mm]	[-]	[mm]	
Nr.8	32	4,166	63	13	22	4,5	3,4	3	3,5	AH0832...
Nr.10	24	4,826	70	16	26,5	6	4,9	3	3,9	AH1024...
Nr.12	24	5,486	80	16	26,5	6	4,9	3	4,5	AH1224...
1/4"	20	6,35	80	17	30	7	5,5	3	5,1	AHA140...
5/16"	18	7,938	90	18	-	6	4,9	3	6,6	AHB516...
3/8"	16	9,525	100	22	-	7	5,5	3	8	AHC380...
7/16"	14	11,113	100	24	-	8	6,2	3	9,4	AHD716...
1/2"	13	12,7	110	26	-	9	7	3	10,8	AHE120...
5/8"	11	15,875	110	28	-	12	9	3	13,5	AHG580...
3/4"	10	19,05	125	32	-	14	11	4	16,5	AHH340...



NEW
P60
TiH1

DIN 2184-1
≤ Ø1/4"

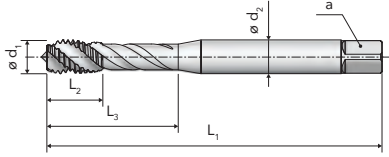

DIN 2184-1
≥ Ø5/16"

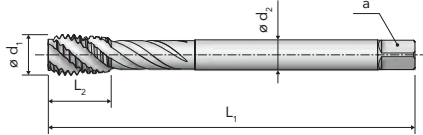

APPLICATION RANGE - CUTTING SPEED m/min

ISO	MG	P60 TiH1			
P	P.3	● 20-30			
	P.4	● 15-25			
	P.5	● 5-15			
	P.7	● 8-10			
M	M.1	● 8-10			
	M.2	● 5-7			
K	K.2	● 20-30			
N	N.3	● 25-35			
	N.6	● 25-35			
S	S.1	● 10-15			
	S.3	● 10-15			



UNC	P	Ød ₁	L ₁ js 16	L ₂	L ₃	Ød ₂ h9	a h12	z		P60 TiH1	...
	[TPI]	[mm]	[mm]	[mm]	[mm]	[mm]	[mm]	[-]	[mm]	...0604A1MHO	
Nr.8	32	4,166	63	9	26	4,5	3,4	3	3,5	AH0832...	
Nr.10	24	4,826	70	11	28,5	6	4,9	3	3,9	AH1024...	
Nr.12	24	5,486	80	11,5	28,5	6	4,9	3	4,5	AH1224...	
1/4"	20	6,35	80	13	32	7	5,5	3	5,1	AHA140...	
5/16"	18	7,938	90	14	-	6	4,9	3	6,6	AHB516...	
3/8"	16	9,525	100	15,5	-	7	5,5	3	8	AHC380...	
7/16"	14	11,113	100	17	-	8	6,2	3	9,4	AHD716...	
1/2"	13	12,7	110	19	-	9	7	4	10,8	AHE120...	
5/8"	11	15,875	110	23,5	-	12	9	4	13,5	AHG580...	
3/4"	10	19,05	125	25	-	14	11	4	16,5	AHH340...	

HIGH PERFORMANCE COLD FORMING TAPS for blind holes
With oil grooves / chamfer form E



NEW
P903 NE
V-MAXX

P903 NE
RED-MAXX

DIN 2184-1
≤ Ø 3/8"

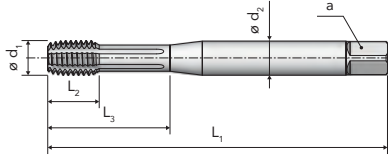

DIN 2184-1
≥ Ø 7/16"

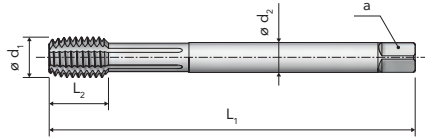

APPLICATION RANGE - CUTTING SPEED m/min

ISO	MG	P903 NE V-MAXX	P903 NE RED-MAXX
P	P.1-2	● 40-45	● 40-45
	P.3	● 35-40	● 35-40
	P.4	● 30-35	● 30-35
	P.5	● 15-20	● 15-20
	P.7	● 10-15	
M	M.1	● 10-15	
N	N.1-2	● 40-45	● 40-45
	N.3	● 35-40	● 35-40
	N.5-6	● 40-45	● 40-45
S	S.3	● 10-15	● 10-15



P SERIES

UNC	P	Ød ₁	L ₁ js16	L ₂	L ₃	Ød ₂ h9	a h12	z		P903 NE V-MAXX ...9038G3MV0	P903 NE RED-MAXX ...9038G3MR0
Nr.8	32	4,166	63	8	22	4,5	3,4	5	3,80	AH0832...	AH0832...
Nr.10	24	4,826	70	11	26	6	4,9	5	4,35	AH1024...	AH1024...
Nr.12	24	5,486	80	11	29	6	4,9	5	5,00	AH1224...	AH1224...
1/4"	20	6,35	80	13	32	7	5,5	5	5,80	AHA140...	AHA140...
5/16"	18	7,938	90	14	35	8	6,2	5	7,30	AHB516...	AHB516...
3/8"	16	9,525	100	16	39	10	8	6	8,80	AHC380...	AHC380...
7/16"	14	11,113	100	19	-	8	6,2	7	10,30	AHD716...	AHD716...
1/2"	13	12,7	110	20	-	9	7	8	11,80	AHE120...	AHE120...
5/8"	11	15,875	110	23	-	12	9	8	14,85	AHG580...	AHG580...
3/4"	10	19,05	125	26	-	14	11	8	17,90	AHH340...	AHH340...



NEW
P20
TiH1

DIN 2184-1
≤ Ø1/4

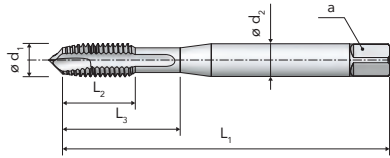

DIN 2184-1
≥ Ø5/16

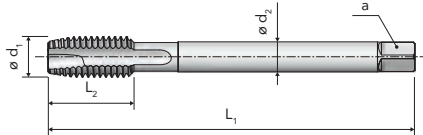

APPLICATION RANGE - CUTTING SPEED m/min

ISO	MG	P20 TiH1			
P	P.3	● 25-35			
	P.4	● 20-30			
	P.5	● 10-20			
	P.6	● 8-10			
	P.7	● 10-15			
M	M.1	● 10-15			
	M.2	● 6-8			
K	K.2	● 25-35			
N	N.2-3	● 30-40			
	N.6	● 25-35			



UNF	P	Ød ₁	L ₁ js 16	L ₂	L ₃	Ød ₂ h9	a h12	z		P20 TiH1	...0205A2MH0
	[TPI]	[mm]	[mm]	[mm]	[mm]	[mm]	[mm]	[-]	[mm]		
Nr.8	36	4,166	63	12	21	4,5	3,4	3	3,5	AN0836...	
Nr.10	32	4,826	70	14	24,5	6	4,9	3	4,1	AN1032...	
Nr.12	28	5,486	80	16	26,5	6	4,9	3	4,6	AN1228...	
1/4"	28	6,35	80	16	30	7	5,5	3	5,5	ANA140...	
5/16"	24	7,938	90	18	-	6	4,9	3	6,9	ANB516...	
3/8"	24	9,525	90	18	-	7	5,5	3	8,5	ANC380...	
7/16"	20	11,113	100	20	-	8	6,2	3	9,9	AND716...	
1/2"	20	12,7	100	22	-	9	7	4	11,5	ANE120...	
5/8"	18	15,875	100	22	-	12	9	4	14,5	ANG580...	
3/4"	16	19,05	110	25	-	14	11	4	17,5	ANH340...	

HIGH PERFORMANCE MACHINE TAPS for blind holes
45° spiral flutes / back tapered



NEW
P61
TiH1

DIN 2184-1
≤ Ø1/4"

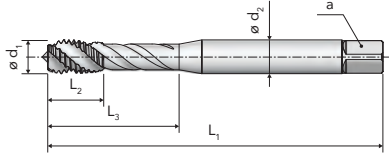

DIN 2184-1
≥ Ø5/16"

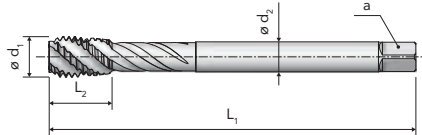

P SERIES

APPLICATION RANGE - CUTTING SPEED m/min

ISO	MG	P61 TiH1			
P	P.3	• 20-30			
	P.4	• 15-25			
	P.5	• 5-15			
	P.7	• 8-10			
M	M.1	• 8-10			
	M.2	• 5-7			
K	K.2	• 20-30			
N	N.3	• 25-35			
	N.6	• 25-35			
S	S.1	• 10-15			
	S.3	• 10-15			

2BX



UNF	P	Ød ₁	L ₁	L ₂	L ₃	Ød ₂	a	z	z	P61 TiH1
	[TPI]	[mm]	_{js 16} [mm]	[mm]	[mm]	_{h9} [mm]	_{h12} [mm]	[-]	[mm]	...0614A1MH0
Nr.8	36	4,166	63	8,0	26	4,5	3,4	3	3,5	AN0836...
Nr.10	32	4,826	70	9,0	28,5	6	4,9	3	4,1	AN1032...
Nr.12	28	5,486	80	9,0	28,5	6	4,9	3	4,6	AN1228...
1/4"	28	6,35	80	9,5	32	7	5,5	3	5,5	ANA140...
5/16"	24	7,938	90	11,0	-	6	4,9	3	6,9	ANB516...
3/8"	24	9,525	90	11,0	-	7	5,5	3	8,5	ANC380...
7/16"	20	11,113	100	12,5	-	8	6,2	3	9,9	AND716...
1/2"	20	12,7	100	13,0	-	9	7	4	11,5	ANE120...
5/8"	18	15,875	100	15,5	-	12	9	4	14,5	ANG580...
3/4"	16	19,05	110	17,5	-	14	11	4	17,5	ANH340...



HSSZ



NEW
P904 NE
V-MAXX

P904 NE
RED-MAXX

DIN 2184-1
≤ Ø 3/8"

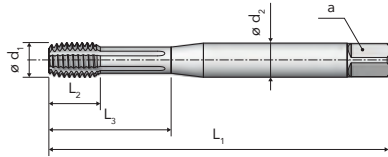

DIN 2184-1
≥ Ø 7/16"

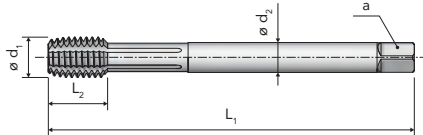

APPLICATION RANGE - CUTTING SPEED m/min

ISO	MG	P904 NE V-MAXX	P904 NE RED-MAXX
P	P.1-2	● 40-45	● 40-45
	P.3	● 35-40	● 35-40
	P.4	● 30-35	● 30-35
	P.5	● 15-20	● 15-20
	P.7	● 10-15	
M	M.1	● 10-15	
N	N.1-2	● 40-45	● 40-45
	N.3	● 35-40	● 35-40
	N.5-6	● 40-45	● 40-45
S	S.3	● 10-15	● 10-15



UNF	P	Ød ₁	L ₁ js 16	L ₂	L ₃	Ød ₂ h9	a h12	z		P904 NE V-MAXX ...904863MV0	P904 NE RED-MAXX ...904863MR0
	[TPI]	[mm]	[mm]	[mm]	[mm]	[mm]	[mm]	[-]	[mm]		
Nr.8	36	4,166	63	7	22	4,5	3,4	5	3,85	AN0836...	AN0836...
Nr.10	32	4,826	70	8	26	6	4,9	5	4,45	AN1032...	AN1032...
Nr.12	28	5,486	80	9	30	6	4,9	5	5,1	AN1228...	AN1228...
1/4"	28	6,35	80	9	32	7	5,5	5	5,95	ANA140...	ANA140...
5/16"	24	7,938	90	11	35	8	6,2	5	7,45	ANB516...	ANB516...
3/8"	24	9,525	90	11	39	10	8	6	9,05	ANC380...	ANC380...
7/16"	20	11,113	100	13	-	8	6,2	7	10,55	AND716...	AND716...
1/2"	20	12,7	100	13	-	9	7	8	12,15	ANE120...	ANE120...
5/8"	18	15,875	100	14	-	12	9	8	15,25	ANG580...	ANG580...
3/4"	16	19,05	110	16	-	14	11	8	18,35	ANH340...	ANH340...



P18
TiN

P18
TiH1

DIN 5156

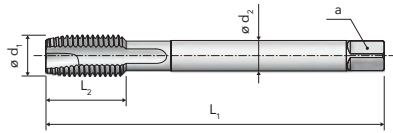

APPLICATION RANGE - CUTTING SPEED m/min

ISO	MG	P18 TiN	P18 TiH1
P	P.3	• 25-35	• 25-35
	P.4	• 20-30	• 20-30
	P.5	• 10-20	• 10-20
	P.6	• 8-10	• 8-10
	P.7	• 10-15	• 10-15
M	M.1	• 10-15	• 10-15
	M.2	• 6-8	• 6-8
K	K.2	• 25-35	• 25-35
N	N.2-3	• 30-40	• 30-40
	N.6	• 25-35	• 25-35



P SERIES

G	P	Ød ₁	L ₁ js16	L ₂	L ₃	Ød ₂ h9	a h12	z	z	P18 TiN ...0185A2LD0	P18 TiH1 ...0185A2LH0
	[TPI]	[mm]	[mm]	[mm]	[mm]	[mm]	[mm]	[-]	[mm]		
1/8"	28	9,728	90	18	-	7	5,5	3	8,8	AGA180...	AGA180...
1/4"	19	13,157	100	22	-	11	9	4	11,8	AGB140...	AGB140...
3/8"	19	16,662	100	22	-	12	9	4	15,25	AGC380...	AGC380...
1/2"	14	20,955	125	25	-	16	12	4	19	AGD120...	AGD120...
5/8"	14	22,911	125	25	-	18	14,5	4	21	AGE580...	AGE580...
3/4"	14	26,441	140	28	-	20	16	5	24,5	AGF340...	AGF340...
1"	11	33,249	160	30	-	25	20	5	30,75	AGH100...	AGH100...



P59
TiN

P59
TiH1

BP59
TiH1

DIN 5156

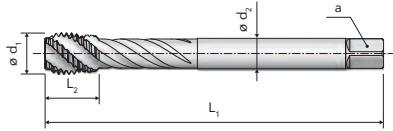

APPLICATION RANGE - CUTTING SPEED m/min

ISO	MG	P59 TiN	P59 TiH1	BP59 TiH1
P	P.3	• 20-30	• 20-30	• 20-30
	P.4	• 15-25	• 15-25	• 15-25
	P.5	• 5-15	• 5-15	• 5-15
	P.7	• 8-10	• 8-10	• 8-10
M	M.1	• 8-10	• 8-10	• 8-10
	M.2	• 5-7	• 5-7	• 5-7
K	K.2	• 20-30	• 20-30	• 20-30
N	N.3	• 25-35	• 25-35	• 25-35
	N.6	• 25-35	• 25-35	• 25-35
S	S.1		• 10-15	• 10-15
	S.3	• 10-15	• 10-15	• 10-15



G	P	$\varnothing d_1$	L_1 js 16	L_2	L_3	$\varnothing d_2$ h9	a h12	z		P59 TiN ...0594A1LDO	P59 TiH1 ...0594A1LHO	BP59 TiH1 ...0594M1LHO
	[TPI]	[mm]	[mm]	[mm]	[mm]	[mm]	[mm]	[-]	[mm]			
1/8"	28	9,728	90	13	-	7	5,5	3	8,8	AGA180...	AGA180...	AGA180...
1/4"	19	13,157	100	16	-	11	9	4	11,8	AGB140...	AGB140...	AGB140...
3/8"	19	16,662	100	16,5	-	12	9	4	15,25	AGC380...	AGC380...	AGC380...
1/2"	14	20,955	125	20,5	-	16	12	5	19	AGD120...	AGD120...	AGD120...
5/8"	14	22,911	125	20,5	-	18	14,5	5	21	AGE580...	AGE580...	AGE580...
3/4"	14	26,441	140	21,5	-	20	16	5	24,5	AGF340...	AGF340...	AGF340...
1"	11	33,249	160	25,5	-	25	20	5	30,75	AGH100...	AGH100...	



P59 E
TiH1

DIN 5156

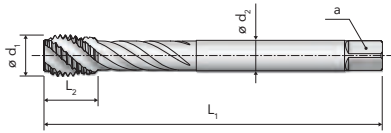

APPLICATION RANGE - CUTTING SPEED m/min

ISO	MG	P59 E TiH1			
P	P.3	• 20-30			
	P.4	• 15-25			
	P.5	• 5-15			
	P.7	• 8-10			
M	M.1	• 8-10			
	M.2	• 5-7			
K	K.2	• 20-30			
N	N.3	• 25-35			
	N.6	• 25-35			
S	S.1	• 10-15			
	S.3	• 10-15			



P SERIES

G	P	Ød ₁	L ₁ js16	L ₂	L ₃	Ød ₂ h9	a h12	z	z	Ø	P59 E TiH1 ...0594A3LHO
	[TPI]	[mm]	[mm]	[mm]	[mm]	[mm]	[mm]	[-]	[mm]	[mm]	
1/8"	28	9,728	90	13	-	7	5,5	3	8,8	8,8	AGA180...
1/4"	19	13,157	100	16	-	11	9	4	11,8	11,8	AGB140...
3/8"	19	16,662	100	16,5	-	12	9	4	15,25	15,25	AGC380...
1/2"	14	20,955	125	20,5	-	16	12	5	19	19	AGD120...
5/8"	14	22,911	125	20,5	-	18	14,5	5	21	21	AGE580...
3/4"	14	26,441	140	21,5	-	20	16	5	24,5	24,5	AGF340...



NEW
P82 N
V-MAXX

DIN 2189

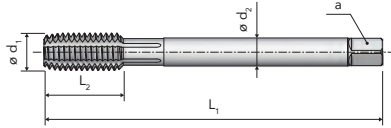

APPLICATION RANGE - CUTTING SPEED m/min

ISO	MG	P82 N V-MAXX			
P	P.1-2	• 20-25			
	P.3	• 15-20			
N	N.1-2	• 20-25			
	N.3	• 15-20			
	N.5-6	• 20-25			



G	P	Ød ₁	L ₁ js 16	L ₂	L ₃	Ød ₂ h9	a h12	Z	z	P82 N V-MAXX ...0828G1AV0
	[TPI]	[mm]	[mm]	[mm]	[mm]	[mm]	[mm]	[-]	[mm]	
1/8"	28	9,728	90	18	-	7	5,5	6	9,25	AGA180...
1/4"	19	13,157	100	22	-	11	9	6	12,5	AGB140...
3/8"	19	16,662	100	22	-	12	9	6	16	AGC380...
1/2"	14	20,955	125	25	-	16	12	6	20	AGD120...
3/4"	14	26,441	140	28	-	20	16	6	25,5	AGF340...



HSSZ



NEW
P902 N
V-MAXX

P902 N
RED-MAXX

DIN 2189

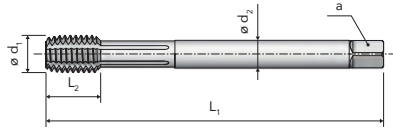

APPLICATION RANGE - CUTTING SPEED m/min

ISO	MG	P902 N V-MAXX	P902 N RED-MAXX
P	P.1-2	• 40-45	• 40-45
	P.3	• 35-40	• 35-40
	P.4	• 30-35	• 30-35
	P.5	• 15-20	• 15-20
	P.7	• 10-15	
M	M.1	• 10-15	
N	N.1-2	• 40-45	• 40-45
	N.3	• 35-40	• 35-40
	N.5-6	• 40-45	• 40-45
S	S.3	• 10-15	• 10-15

ISO
5969 X

ISO
5969 X



P SERIES

G	P	Ød ₁	L ₁ js16	L ₂	L ₃	Ød ₂ h9	a h12	z	z	P902 N V-MAXX ...9028G1LV0	P902 N RED-MAXX ...9028G1LR0
	[TPI]	[mm]	[mm]	[mm]	[mm]	[mm]	[mm]	[-]	[mm]		
1/8"	28	9,728	90	12	-	7	5,5	6	9,25	AGA180...	AGA180...
1/4"	19	13,157	100	17	-	11	9	8	12,5	AGB140...	AGB140...
3/8"	19	16,662	100	17	-	12	9	8	16	AGC380...	AGC380...
1/2"	14	20,955	125	23	-	16	12	8	20	AGD120...	AGD120...
3/4"	14	26,441	140	23	-	20	16	8	25,5	AGF340...	AGF340...



HSSZ



NEW
P902 NE
V-MAXX

P902 NE
RED-MAXX

DIN 2189

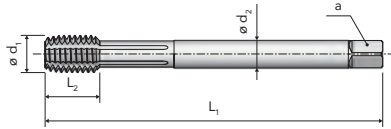

APPLICATION RANGE - CUTTING SPEED m/min

ISO	MG	P902 NE V-MAXX	P902 NE RED-MAXX
P	P.1-2	• 40-45	• 40-45
	P.3	• 35-40	• 35-40
	P.4	• 30-35	• 30-35
	P.5	• 15-20	• 15-20
	P.7	• 10-15	
M	M.1	• 10-15	
N	N.1-2	• 40-45	• 40-45
	N.3	• 35-40	• 35-40
	N.5-6	• 40-45	• 40-45
S	S.3	• 10-15	• 10-15

ISO
5969 X

ISO
5969 X



G	P	$\varnothing d_1$	L_1 js 16	L_2	L_3	$\varnothing d_2$ h9	a h12	z		P902 NE V-MAXX ...9028G3LV0	P902 NE RED-MAXX ...9028G3LR0
	[TPI]	[mm]	[mm]	[mm]	[mm]	[mm]	[mm]	[-]	[mm]		
1/8"	28	9,728	90	12	-	7	5,5	6	9,25	AGA180...	AGA180...
1/4"	19	13,157	100	17	-	11	9	8	12,5	AGB140...	AGB140...
3/8"	19	16,662	100	17	-	12	9	8	16	AGC380...	AGC380...
1/2"	14	20,955	125	23	-	16	12	8	20	AGD120...	AGD120...



BP902 N R
RED-MAXX

DIN 2189

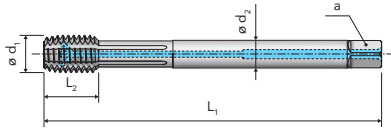

P SERIES

APPLICATION RANGE - CUTTING SPEED m/min

ISO	MG	BP902 N R RED-MAXX			
P	P.1-2	• 40-45			
	P.3	• 35-40			
	P.4	• 30-35			
	P.5	• 15-20			
N	N.1-2	• 40-45			
	N.3	• 35-40			
	N.5-6	• 40-45			
S	S.3	• 10-15			



G	P	$\varnothing d_1$	L_1 js 16	L_2	L_3	$\varnothing d_2$ h9	a h12	z		BP902 N R RED-MAXX ...9028R1LR0			
	[TPI]	[mm]	[mm]	[mm]	[mm]	[mm]	[mm]	[-]	[mm]				
1/8"	28	9,728	90	12	-	7	5,5	6	9,25	AGA180...			
1/4"	19	13,157	100	17	-	11	9	8	12,5	AGB140...			
3/8"	19	16,662	100	17	-	12	9	8	16	AGC380...			
1/2"	14	20,955	125	23	-	16	12	8	20	AGD120...			



S SERIES

SYNCHRONOUS TAPS





S43
V-MAXX

BS43
V-MAXX

S43 E
V-MAXX

BS43 E
V-MAXX

~DIN 371
≤ M12 (*)

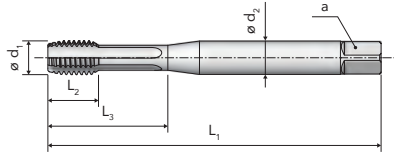

~DIN 376
≥ M16 (*)

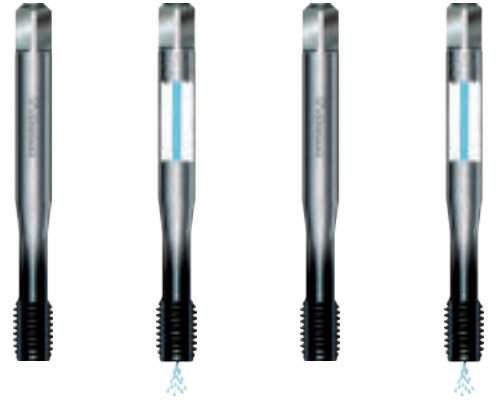
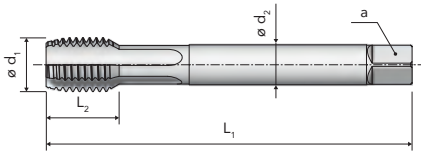

APPLICATION RANGE - CUTTING SPEED m/min

ISO	MG	S43 V-MAXX	BS43 V-MAXX	S43 E V-MAXX	BS43 E V-MAXX
K	K.1	● 55-65	● 55-65	● 55-65	● 55-65
	N.4	● 55-65	● 55-65	● 55-65	● 55-65
N	N.7	● 55-65	● 55-65	● 55-65	● 55-65
	N.9-10	● 55-65	● 55-65	● 55-65	● 55-65



Ød ₁	P	L ₁ js 16	L ₂	L ₃	Ød ₂ h6	a h12	Z	Ø	S43 V-MAXX ...0433N1AV0	BS43 V-MAXX ...0433P1AV0	S43 E V-MAXX ...0433N3AV0	BS43 E V-MAXX ...0433P3AV0
[mm]	[mm]	[mm]	[mm]	[mm]	[mm]	[mm]	[-]	[mm]				
M 3	0,5	70	5	15	6	4,9	3	2,5	A00030...			
4	0,7	70	7	18	6	4,9	3	3,3	A00040...		A00040...	
5	0,8	70	8	23	6	4,9	3	4,2	A00050...	A00050...	A00050...	A00050...
6	1	80	10	29	6	4,9	4	5	A00060...	A00060...	A00060...	A00060...
8	1,25	90	11	33	8	6,2	4	6,8	A00080...	A00080...	A00080...	A00080...
10	1,5	100	13	36	10	8	4	8,5	A00100...	A00100...	A00100...	A00100...
12	1,75	110	16	42	12	9	4	10,2	A00120...	A00120...	A00120...	A00120...
16	2	110	18	-	12	9	4	14	A00160...	A00160...	A00160...	A00160...
20	2,5	140	23	-	16	12	4	17,5	A00200...	A00200...	A00200...	A00200...

(*)= DIN 1835-B on request



S15
TiN

S15
TiH1

BS15
TiH1

~DIN 371
≤ M12 (*)

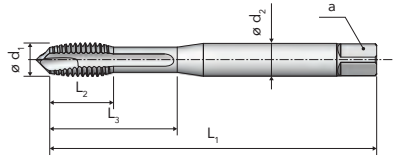

~DIN 376
≥ M14 (*)

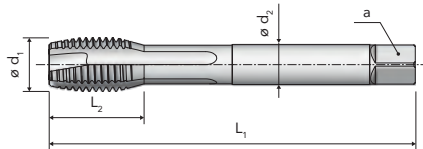

APPLICATION RANGE - CUTTING SPEED m/min

ISO	MG	S15 TiN	S15 TiH1	BS15 TiH1
P	P.1-2	● 50-60	● 50-60	● 50-60
	P.3	● 45-55	● 45-55	● 45-55
	P.4	● 40-50	● 40-50	● 40-50
	P.5	● 15-25	● 15-25	● 15-25
	P.7	● 15-25	● 15-25	● 15-25
M	M.1	● 15-25	● 15-25	● 15-25
	M.2	● 10-20	● 10-20	● 10-20
K	K.2	● 45-55	● 45-55	● 45-55
N	N.1	● 50-60	● 50-60	● 50-60
	N.2-3	● 45-55	● 45-55	● 45-55
	N.5	● 40-50	● 40-50	● 40-50
	N.6	● 35-45	● 35-45	● 35-45
S	S.1	● 15-25	● 15-25	● 15-25
	S.3	● 15-25	● 15-25	● 15-25



S SERIES

Ød ₁	P	L ₁ js16	L ₂	L ₃	Ød ₂ h6	a h12	Z		S15 TiN ...0153N2ADO	S15 TiH1 ...0153N2AHO	BS15 TiH1 ...0153P2AHO
[mm]	[mm]	[mm]	[mm]	[mm]	[mm]	[mm]	[-]	[mm]			
M3	0,5	70	5	15	6	4,9	3	2,5	A00030...	A00030...	
4	0,7	70	7	18	6	4,9	3	3,3	A00040...	A00040...	
5	0,8	70	8	25	6	4,9	3	4,2	A00050...	A00050...	A00050...
6	1	80	10	30	6	4,9	3	5	A00060...	A00060...	A00060...
8	1,25	90	12,5	35	8	6,2	3	6,8	A00080...	A00080...	A00080...
10	1,5	100	15	39	10	8	3	8,5	A00100...	A00100...	A00100...
12	1,75	110	17,5	42	12	9	3	10,2	A00120...	A00120...	A00120...
14	2	110	20	-	12	9	3	12	A00140...	A00140...	
16	2	110	20	-	12	9	4	14	A00160...	A00160...	A00160...

(*)= DIN 1835-B on request



S70
TiN

S70
TiH1

BS70
TiH1

~DIN 371
≤ M12 (*)

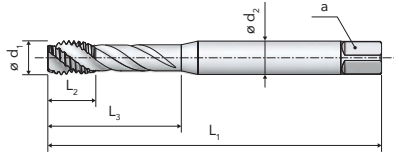

~DIN 376
≥ M14 (*)

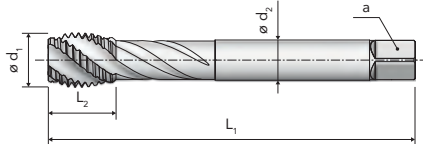

6HX

6HX

6HX



APPLICATION RANGE - CUTTING SPEED m/min

ISO	MG	S70 TiN	S70 TiH1	BS70 TiH1
P	P.1-2	● 45-55	● 45-55	● 45-55
	P.3	● 40-50	● 40-50	● 40-50
	P.4	● 35-45	● 35-45	● 35-45
	P.5	● 15-20	● 15-20	● 15-20
	P.7	● 15-20	● 15-20	● 15-20
M	M.1	● 15-20	● 15-20	● 15-20
K	K.2	● 40-50	● 40-50	● 40-50
N	N.1	● 45-55	● 45-55	● 45-55
	N.2-3	● 40-50	● 40-50	● 40-50
	N.5	● 35-45	● 35-45	● 35-45
	N.6	● 30-40	● 30-40	● 30-40
S	S.1		● 15-20	● 15-20
	S.3	● 15-20	● 15-20	● 15-20

$\varnothing d_1$	P	L_1 js 16	L_2	L_3	$\varnothing d_2$ h6	a h12	Z		S70 TiN ...0703N1ADO	S70 TiH1 ...0703N1AHO	BS70 TiH1 ...0703P1AHO
[mm]	[mm]	[mm]	[mm]	[mm]	[mm]	[mm]	[-]	[mm]			
M 3	0,5	70	5,5	14	6	4,9	3	2,5	A00030...	A00030...	
4	0,7	70	7,5	18	6	4,9	3	3,3	A00040...	A00040...	
5	0,8	70	8,5	25	6	4,9	3	4,2	A00050...	A00050...	A00050...
6	1	80	10,5	30	6	4,9	3	5	A00060...	A00060...	A00060...
8	1,25	90	11,5	35	8	6,2	3	6,8	A00080...	A00080...	A00080...
10	1,5	100	14	40	10	8	3	8,5	A00100...	A00100...	A00100...
12	1,75	110	16,5	42	12	9	3	10,2	A00120...	A00120...	A00120...
14	2	110	19	-	12	9	3	12	A00140...	A00140...	
16	2	110	19	-	12	9	4	14	A00160...	A00160...	A00160...

(*)= DIN 1835-B on request

COLD FORMING TAPS FOR SYNCHRONOUS TAPPING for blind and through holes
With oil grooves

DIN 13



S80 N
TiN

S80 N
V-MAXX

S80 N 6GX
TiN

BS80 N R
TiN

~DIN 371(*)

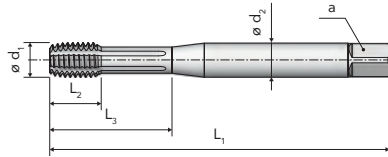

APPLICATION RANGE - CUTTING SPEED m/min					
ISO	MG	S80 N TiN	S80 N V-MAXX	S80 N 6GX TiN	BS80 N R TiN
P	P.1-2	● 50-60	● 50-60	● 50-60	● 50-60
	P.3	● 45-55	● 45-55	● 45-55	● 45-55
	P.4	● 40-50	● 40-50	● 40-50	● 40-50
	P.5	● 20-30	● 20-30	● 20-30	● 20-30
	P.7	● 10-20	● 10-20	● 10-20	● 10-20
M	M.1	● 10-20	● 10-20	● 10-20	● 10-20
	M.2	● 50-60	● 50-60	● 50-60	● 50-60
N	N.1-2	● 45-55	● 45-55	● 45-55	● 45-55
	N.3	● 50-60	● 50-60	● 50-60	● 50-60
	N.5-6	● 10-20	● 10-20	● 10-20	● 10-20
S	S.3	● 10-20	● 10-20	● 10-20	● 10-20

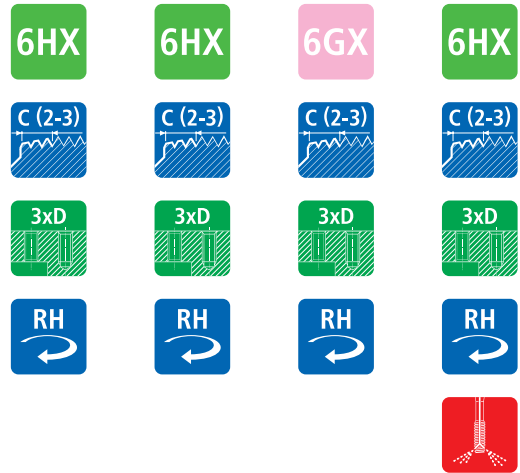

S SERIES

$\varnothing d_1$	P	L_1 js16	L_2	L_3	$\varnothing d_2$ h6	a h12	z		S80 N TiN ...0808N1A00	S80 N V-MAXX ...0808N1A00	S80 N 6GX TiN ...0808N1C00	BS80 N R TiN ...0808P1A00
[mm]	[mm]	[mm]	[mm]	[mm]	[mm]	[mm]	[-]	[mm]				
M 4	0,7	70	7	18	6	4,9	5	3,7	A00040...	A00040...	A00040...	A00040...
5	0,8	70	8	23	6	4,9	5	4,65	A00050...	A00050...	A00050...	A00050...
6	1	80	10	29	6	4,9	5	5,55	A00060...	A00060...	A00060...	A00060...
8	1,25	90	11	33	8	6,2	5	7,4	A00080...	A00080...	A00080...	A00080...
10	1,5	100	13	36	10	8	5	9,3	A00100...	A00100...	A00100...	A00100...
12	1,75	110	16	42	12	9	5	11,2	A00120...	A00120...	A00120...	A00120...

(*)= DIN 1835-B on request



S45
V-MAXX

BS45
V-MAXX

~DIN 371
≤ M12x1,5 (*)

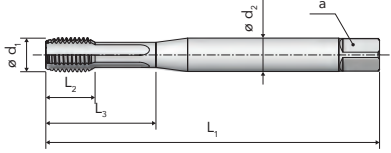

~DIN 376
≥ M14x1,5 (*)

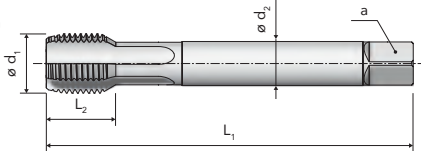

APPLICATION RANGE - CUTTING SPEED m/min

ISO	MG	S45 V-MAXX	BS45 V-MAXX
K	K.1	● 55-65	● 55-65
	N.4	● 55-65	● 55-65
N	N.7	● 55-65	● 55-65
	N.9-10	● 55-65	● 55-65

S SERIES

$\varnothing d_1$	P	L_1 js 16	L_2	L_3	$\varnothing d_2$ h6	a h12	Z		S45 V-MAXX ...0453N1AV0	BS45 V-MAXX ...0453P1AV0
[mm]	[mm]	[mm]	[mm]	[mm]	[mm]	[mm]	[-]	[mm]		
M 8	1	90	10	33	8	6,2	4	7	A08100...	A08100...
10	1	90	10	33	10	8	4	9	A10100...	A10100...
10	1,25	100	12,5	33	10	8	4	8,8	A10125...	A10125...
12	1,25	100	12,5	33	12	9	4	10,8	A12125...	A12125...
12	1,5	100	15	37	12	9	4	10,5	A12150...	A12150...
14	1,5	100	15	-	12	9	4	12,5	A14150...	A14150...
16	1,5	100	15	-	12	9	4	14,5	A16150...	A16150...
20	1,5	125	17	-	16	12	4	18,5	A20150...	A20150...

(*)= DIN 1835-B on request



S71
TiN

~DIN 371
≤ M12x1,5 (*)

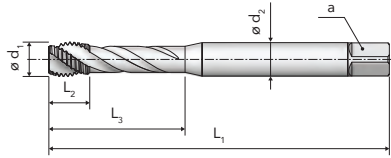

~DIN 376
≥ M14x1,5 (*)

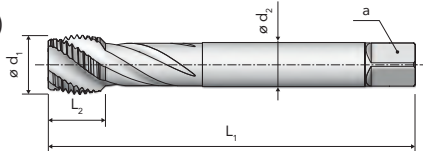

APPLICATION RANGE - CUTTING SPEED m/min

ISO	MG	S71 TiN			
P	P.1-2	● 45-55			
	P.3	● 40-50			
	P.4	● 35-45			
	P.5	● 15-20			
	P.7	● 15-20			
M	M.1	● 15-20			
K	K.2	● 40-50			
N	N.1	● 45-55			
	N.2-3	● 40-50			
	N.5	● 35-45			
	N.6	● 30-40			
S	S.3	● 15-20			



S SERIES

$\varnothing d_1$	P	L_1 js 16	L_2	L_3	$\varnothing d_2$ h6	a h12	Z		S71 TiN	...
[mm]	[mm]	[mm]	[mm]	[mm]	[mm]	[mm]	[-]	[mm]	...0713N1A00	
M 8	1	90	10	35	8	6,2	3	7	A08100...	
10	1	90	10	40	10	8	3	9	A10100...	
10	1,25	100	11,5	40	10	8	3	8,8	A10125...	
12	1,25	100	11,5	40	12	9	3	10,8	A12125...	
12	1,5	100	14	42	12	9	3	10,5	A12150...	
14	1,5	100	14	-	12	9	4	12,5	A14150...	
16	1,5	100	14	-	12	9	4	14,5	A16150...	

(*)= DIN 1835-B on request



SERIE H
SOLID CARBIDE TAPS

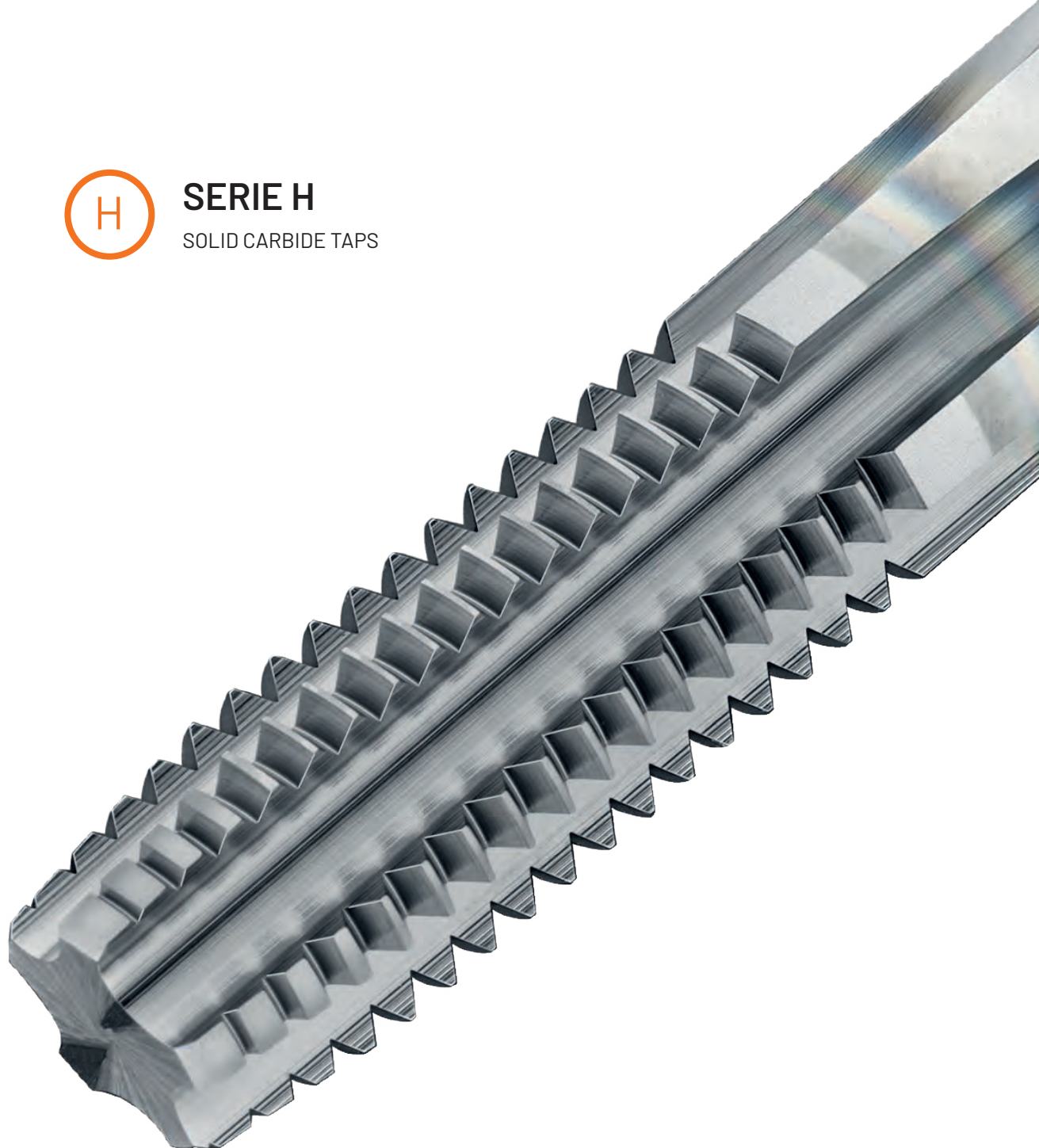



HB43
BRIGHT

HB43
V-MAXX

HB43 E
V-MAXX

DIN 371
≤ M10

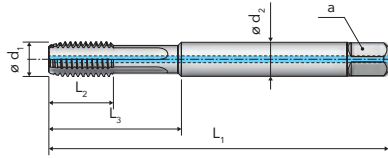

DIN 376
≥ M12

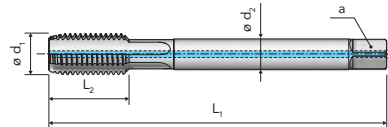

6HX

2,5xD

RH

6HX

2,5xD

RH

6HX

2,5xD

RH

APPLICATION RANGE - CUTTING SPEED m/min

ISO	MG	HB43 BRIGHT	HB43 V-MAXX	HB43 E V-MAXX
K	K.1	● 40-50	● 55-65	● 55-65
	N.4	● 40-50	● 55-65	● 55-65
N	N.7	● 40-50	● 55-65	● 55-65
	N.9-10	● 45-55	● 55-65	● 55-65

H SERIES

$\varnothing d_1$	P	L_1 js 16	L_2	L_3	$\varnothing d_2$ h6	a h12	Z		HB43 BRIGHT ...0439M1AA0	HB43 V-MAXX ...0439M1AV0	HB43 E V-MAXX ...0439M3AV0
[mm]	[mm]	[mm]	[mm]	[mm]	[mm]	[mm]	[-]	[mm]			
M 3(*)	0,5	56	8	18	3,5	2,7	3	2,5	A00030...	A00030...	
4(*)	0,7	63	10	21	4,5	3,4	4	3,3	A00040...	A00040...	
5	0,8	70	10	25	6	4,9	4	4,2	A00050...	A00050...	A00050...
6	1	80	12	30	6	4,9	4	5	A00060...	A00060...	A00060...
8	1,25	90	16	35	8	6,2	4	6,8	A00080...	A00080...	A00080...
10	1,5	100	18	39	10	8	4	8,5	A00100...	A00100...	A00100...
NEW 12	1,75	110	22	-	9	7	4	10,2	A00120...	A00120...	A00120...

(*)= Taps without through coolant



HB29
BRIGHT

HB29
V-MAXX

DIN 371

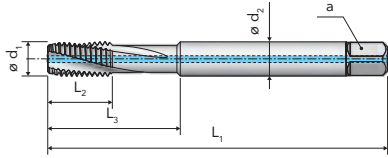

APPLICATION RANGE - CUTTING SPEED m/min

ISO	MG	HB29 BRIGHT	HB29 V-MAXX
N	N.1-2	• 15-30	• 25-50
	N.3	• 20-30	• 30-50
	N.4	• 15-20	• 25-40
	N.7	• 20-25	• 30-40



H SERIES

$\varnothing d_1$	P	L_1 js 16	L_2	L_3	$\varnothing d_2$ h6	a h12	Z		HB29 BRIGHT ...0299M1AA0	HB29 V-MAXX ...0299M1AV0
[mm]	[mm]	[mm]	[mm]	[mm]	[mm]	[mm]	[-]	[mm]		
M 3(*)	0,5	56	8	18	3,5	2,7	3	2,5	A00030...	A00030...
4(*)	0,7	63	10	21	4,5	3,4	3	3,3	A00040...	A00040...
5	0,8	70	10	25	6	4,9	3	4,2	A00050...	A00050...
6	1	80	12	30	6	4,9	3	5	A00060...	A00060...
8	1,25	90	16	35	8	6,2	3	6,8	A00080...	A00080...
10	1,5	100	18	39	10	8	3	8,5	A00100...	A00100...

(*) = Taps without through coolant



HB80 N R
V-MAXX

HB80 N R E
V-MAXX

~DIN 2174 (371)
≤ M10

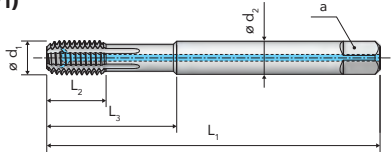

DIN 2174 (376)
≥ M12

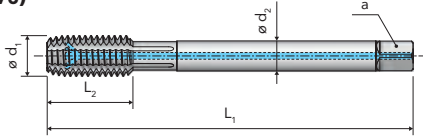

APPLICATION RANGE - CUTTING SPEED m/min

ISO	MG	HB80 N R V-MAXX	HB80 N R E V-MAXX
P	P.1-2	● 40-50	● 40-50
	P.3	● 35-45	● 35-45
	P.4	● 30-40	● 30-40
	P.5	● 15-25	● 15-25
	P.7	● 10-20	● 10-20
M	M.1	● 10-20	● 10-20
N	N.1-2	● 40-50	● 40-50
	N.3	● 35-45	● 35-45
	N.5-6	● 40-50	● 40-50
S	S.3	● 10-20	● 10-20

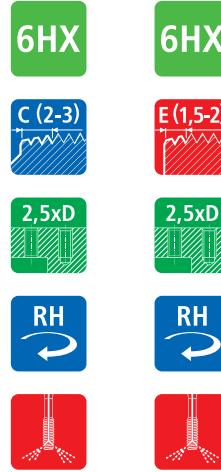

H SERIES

$\varnothing d_1$	P	L_1 js16	L_2	L_3	$\varnothing d_2$ h6	a h12	Z		HB80 N R V-MAXX ...0809R1AV0	HB80 N R E V-MAXX ...0809R3AAV0
[mm]	[mm]	[mm]	[mm]	[mm]	[mm]	[mm]	[-]	[mm]		
M 3(*)	0,5	56	6	18	3,5	2,7	4	2,8	A00030...	A00030...
4(*)	0,7	63	7,5	21	4,5	3,4	5	3,7	A00040...	A00040...
5	0,8	70	8,5	25	6	4,9	5	4,65	A00050...	A00050...
6	1	80	11	30	6	4,9	5	5,55	A00060...	A00060...
8	1,25	90	14	35	8	6,2	5	7,4	A00080...	A00080...
10	1,5	100	16	39	10	8	5	9,3	A00100...	A00100...
NEW 12	1,75	110	18	-	9	7	6	11,2	A00120...	A00120...

(*)= Taps without through coolant



HB45
BRIGHT

HB45
V-MAXX

HB45 E
V-MAXX

DIN 374

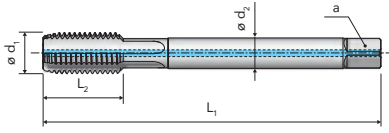

6HX

6HX

6HX



APPLICATION RANGE - CUTTING SPEED m/min

ISO	MG	HB45 BRIGHT	HB45 V-MAXX	HB45 E V-MAXX
K	K.1	● 40-50	● 55-65	● 55-65
	N.4	● 40-50	● 55-65	● 55-65
N	N.7	● 40-50	● 55-65	● 55-65
	N.9-10	● 45-55	● 55-65	● 55-65

H SERIES

$\varnothing d_1$	P	L_1 js 16	L_2	L_3	$\varnothing d_2$ h6	a h12	Z		HB45 BRIGHT ...0459M1AA0	HB45 V-MAXX ...0459M1AV0	HB45 E V-MAXX ...0459M3AV0
[mm]	[mm]	[mm]	[mm]	[mm]	[mm]	[mm]	[-]	[mm]			
M 10	1	90	18	-	7	5,5	4	9	A10100...	A10100...	A10100...
12	1,25	100	22	-	9	7	4	10,8	A12125...	A12125...	A12125...
12	1,5	100	22	-	9	7	4	10,5	A12150...	A12150...	A12150...
14	1,5	100	22	-	11	9	4	12,5	A14150...	A14150...	A14150...
16	1,5	100	22	-	12	9	4	14,5	A16150...	A16150...	A16150...

SOLID CARBIDE COLD FORMING TAPS for blind and through holes
With oil grooves / internal coolant / chamfer form E



HB81 N RE
V-MAXX

DIN 2174 (371)
≤ M10x1,25

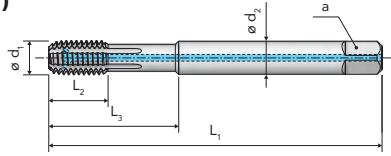

DIN 2174 (374)
≥ M12x1,25

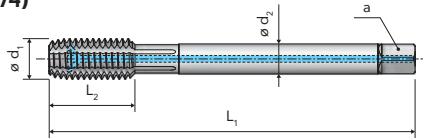

APPLICATION RANGE - CUTTING SPEED m/min

ISO	MG	HB81 N RE V-MAXX			
P	P.1-2	● 40-50			
	P.3	● 35-45			
	P.4	● 30-40			
	P.5	● 15-25			
	P.7	● 10-20			
M	M.1	● 10-20			
N	N.1-2	● 40-50			
	N.3	● 35-45			
	N.5-6	● 40-50			
S	S.3	● 10-20			



H SERIES

$\varnothing d_1$	P	L_1 js16	L_2	L_3	$\varnothing d_2$ h6	a h12	Z		HB81 N RE V-MAXX ...0819R3AV0
[mm]	[mm]	[mm]	[mm]	[mm]	[mm]	[mm]	[-]	[mm]	
M 8	1	90	14	35	8	6,2	5	7,55	A08100...
10	1	90	14	35	10	8	6	9,55	A10100...
10	1,25	100	15	39	10	8	6	9,4	A10125...
12	1,25	100	15	-	9	7	6	11,4	A12125...
12	1,5	100	15	-	9	7	6	11,3	A12150...
14	1,5	100	16	-	11	9	6	13,3	A14150...
16	1,5	100	16	-	12	9	6	15,3	A16150...



F SERIES
DIES



X200
BRIGHTX200 LH
BRIGHT

DIN EN 22568

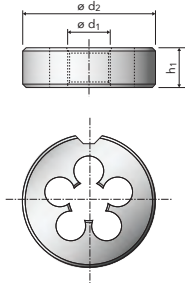

APPLICATION RANGE

ISO	MG	X200 BRIGHT	X200 LH BRIGHT		
P	P.1-4	•	•		
	P.7	•	•		
M	M.1	•	•		
K	K.2	•	•		
N	N.1-3	•	•		
	N.5-7	•	•		



$\varnothing d_1$	P	$\varnothing d_2$	h_1	z	X200 BRIGHT ...D00000	X200 LH BRIGHT ...S00000
[mm]	[mm]	[mm]	[mm]	[-]		
M 2	0,4	16	5	3	X20000020...	
2,2	0,45	16	5	3	X20000022...	
2,5	0,45	16	5	3	X20000025...	
3	0,5	20	5	4	X20000030...	X20000030...
3,5	0,6	20	5	4	X20000035...	
4	0,7	20	5	4	X20000040...	X20000040...
5	0,8	20	7	4	X20000050...	X20000050...
6	1	20	7	4	X20000060...	X20000060...
7	1	25	9	4	X20000070...	
8	1,25	25	9	4	X20000080...	X20000080...
9	1,25	25	9	4	X20000090...	
10	1,5	30	11	4	X20000100...	X20000100...
11	1,5	30	11	5	X20000110...	
12	1,75	38	14	4	X20000120...	X20000120...
14	2	38	14	4	X20000140...	X20000140...
16	2	45	18	4	X20000160...	
18	2,5	45	18	5	X20000180...	
20	2,5	45	18	5	X20000200...	
22	2,5	55	22	5	X20000220...	
24	3	55	22	5	X20000240...	
27	3	65	25	5	X20000270...	
30	3,5	65	25	6	X20000300...	
33	3,5	65	25	6	X20000330...	
36	4	65	25	7	X20000360...	
39	4	75	30	6	X20000390...	



X201
BRIGHT

DIN EN 22568

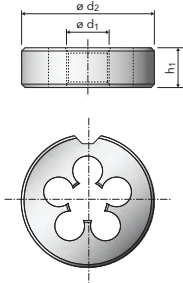

APPLICATION RANGE

ISO	MG	X201 BRIGHT			
P	P.1-4	•			
	P.7	•			
M	M.1	•			
K	K.2	•			
N	N.1-3	•			
	N.5-7	•			



$\varnothing d_1$	P	$\varnothing d_2$	h1	z	X201 BRIGHT ...D00000
[mm]	[mm]	[mm]	[mm]	[-]	
M2	0,25	16	5	3	X20102025...
2,2	0,25	16	5	3	X20102225...
2,5	0,35	16	5	3	X20102535...
3	0,35	20	5	4	X20103035...
4	0,5	20	5	4	X20104050...
5	0,5	20	5	4	X20105050...
6	0,75	20	7	4	X20106075...
7	0,75	25	9	4	X20107075...
8	0,75	25	9	4	X20108075...
8	1	25	9	4	X20108100...
9	1	25	9	5	X20109100...
10	0,75	30	11	5	X20110075...
10	1	30	11	4	X20110100...
10	1,25	30	11	4	X20110125...
11	1	30	11	5	X20111100...
12	1	38	10	5	X20112100...
12	1,25	38	10	4	X20112125...
12	1,5	38	10	4	X20112150...
14	1	38	10	5	X20114100...
14	1,25	38	10	5	X20114125...
14	1,5	38	10	5	X20114150...
15	1	38	10	5	X20115100...
15	1,5	38	10	5	X20115150...
16	1	45	14	5	X20116100...
16	1,5	45	14	5	X20116150...
18	1	45	14	5	X20118100...

F SERIES





X201
BRIGHT

DIN EN 22568

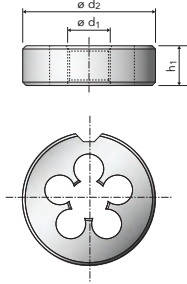

APPLICATION RANGE

ISO	MG	X201 BRIGHT			
P	P.1-4	•			
	P.7	•			
M	M.1	•			
K	K.2	•			
N	N.1-3	•			
	N.5-7	•			



«

$\varnothing d_1$	P	$\varnothing d_2$	h_1	z	X201 BRIGHT ...D00000
[mm]	[mm]	[mm]	[mm]	[-]	
M 18	1,5	45	14	5	X20118150...
18	2	45	14	5	X20118200...
20	1	45	14	6	X20120100...
20	1,5	45	14	6	X20120150...
20	2	45	14	6	X20120200...
22	1	55	16	6	X20122100...
22	1,5	55	16	6	X20122150...
22	2	55	16	6	X20122200...
24	1	55	16	6	X20124100...
24	1,5	55	16	6	X20124150...
24	2	55	16	6	X20124200...
25	1	55	16	6	X20125100...
25	1,5	55	16	6	X20125150...
25	2	55	16	6	X20125200...
26	1,5	55	16	6	X20126150...
27	1,5	65	18	6	X20127150...
27	2	65	18	6	X20127200...
28	1,5	65	18	6	X20128150...
28	2	65	18	6	X20128200...
30	1	65	18	6	X20130100...
30	1,5	65	18	6	X20130150...
30	2	65	18	6	X20130200...
32	1,5	65	18	7	X20132150...
32	2	65	18	7	X20132200...
33	2	65	18	7	X20133200...
35	1,5	65	18	8	X20135150...

»



X204
BRIGHT

DIN EN 22568

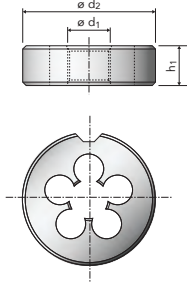

APPLICATION RANGE

ISO	MG	X204 BRIGHT			
P	P.1-4	•			
	P.7	•			
M	M.1	•			
K	K.2	•			
N	N.1-3	•			
	N.5-7	•			

2A



UNC	P	Ød ₁	Ød ₂	h ₁	z	X204 BRIGHT ...D00000
	[TPI]	[mm]	[mm]	[mm]	[-]	
Nr. 2	56	2,184	16	5	3	X204H0256...
Nr. 4	40	2,845	20	5	3	X204H0440...
Nr. 5	40	3,175	20	5	4	X204H0540...
Nr. 6	32	3,505	20	7	4	X204H0632...
Nr. 8	32	4,166	20	7	4	X204H0832...
Nr. 10	24	4,826	20	7	4	X204H1024...
Nr. 12	24	5,486	20	7	4	X204H1224...
1/4"	20	6,35	20	7	4	X204HA140...
5/16"	18	7,938	25	9	4	X204HB516...
3/8"	16	9,525	30	11	4	X204HC380...
7/16"	14	11,113	30	11	4	X204HD716...
1/2"	13	12,7	38	14	4	X204HE120...
9/16"	12	14,288	38	14	4	X204HF916...
5/8"	11	15,875	45	18	4	X204HG580...
3/4"	10	19,05	45	18	5	X204HH340...
7/8"	9	22,225	55	22	5	X204HL780...
1"	8	25,4	55	22	5	X204HM100...

F SERIES



X205
BRIGHT

DIN EN 22568

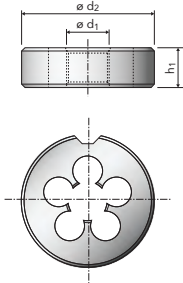

APPLICATION RANGE

ISO	MG	X205 BRIGHT			
P	P.1-4	•			
	P.7	•			
M	M.1	•			
K	K.2	•			
N	N.1-3	•			
	N.5-7	•			

2A



UNF	P	$\varnothing d_1$	$\varnothing d_2$	h1	z	X205 BRIGHT ...D00000
	[TPI]	[mm]	[mm]	[mm]	[-]	
Nr. 3	56	2,515	16	5	3	X205N0356...
Nr. 4	48	2,845	20	5	3	X205N0448...
Nr. 5	44	3,175	20	5	3	X205N0544...
Nr. 6	40	3,505	20	5	4	X205N0640...
Nr. 8	36	4,166	20	7	4	X205N0836...
Nr. 10	32	4,826	20	7	4	X205N1032...
Nr. 12	28	5,486	20	7	4	X205N1228...
1/4"	28	6,35	20	7	4	X205NA140...
5/16"	24	7,938	25	9	4	X205NB516...
3/8"	24	9,525	30	11	4	X205NC380...
7/16"	20	11,113	30	11	5	X205ND716...
1/2"	20	12,7	38	10	5	X205NE120...
9/16"	18	14,288	38	10	5	X205NF916...
5/8"	18	15,875	45	14	4	X205NG580...
3/4"	16	19,05	45	14	6	X205NH340...
7/8"	14	22,225	55	16	5	X205NL780...
1"	12	25,4	55	16	6	X205NM100...

F SERIES

X203
BRIGHT

DIN EN 24231

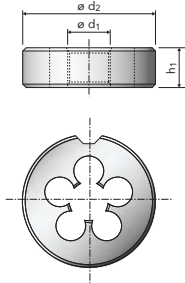

APPLICATION RANGE

ISO	MG	X203 BRIGHT			
P	P.1-4	•			
	P.7	•			
M	M.1	•			
K	K.2	•			
N	N.1-3	•			
	N.5-7	•			



G	P	$\varnothing d_1$	$\varnothing d_2$	h1	z	X203 BRIGHT ...D00000
	[TPI]	[mm]	[mm]	[mm]	[-]	
1/8"	28	9,728	30	11	4	X203GA180...
1/4"	19	13,157	38	10	5	X203GB140...
3/8"	19	16,662	45	14	5	X203GC380...
1/2"	14	20,955	45	14	6	X203GD120...
5/8"	14	22,911	55	16	5	X203GE580...
3/4"	14	26,441	55	16	6	X203GF340...
7/8"	14	30,201	65	18	6	X203GG780...
1"	11	33,249	65	18	7	X203GH100...
1 1/4"	11	41,91	75	20	7	X203GM114...
1 1/2"	11	47,803	90	22	8	X203GP112...
2"	11	59,614	105	22	8	X203GR200...



VR SERIES
THREAD MILLS



APPLICATION AND CUTTING SPEED TABLE

VR10 - VR20 - VR30															
ISO 513	Material	Group	Application	N/mm ²	Vc m/min	Feed (mm/tooth)									
						Ø2	Ø3	Ø4	Ø6	Ø8	Ø10	Ø12	Ø14	Ø16	Ø20
P	Steel	P.1	Mild / magnetic steel	200 - 400	100-250	0,03	0,04	0,04	0,06	0,07	0,08	0,09	0,11	0,12	0,15
		P.2	Construction steel, case hardening steel	350 - 700	100-250	0,03	0,04	0,04	0,06	0,07	0,08	0,09	0,11	0,12	0,15
		P.3	Carbon steel	350 - 850	100-250	0,03	0,04	0,04	0,06	0,07	0,08	0,09	0,11	0,12	0,15
		P.4	Alloyed steel, tempered steel	500 - 850	110-180	0,02	0,03	0,03	0,05	0,06	0,07	0,08	0,09	0,1	0,12
		P.5	Alloyed steel, tempered steel	850 - 1200	90-160	0,02	0,02	0,03	0,03	0,04	0,05	0,05	0,06	0,07	0,08
		P.6	Alloyed steel / high strength steel	1200 - 1600	90-140	0,02	0,02	0,02	0,02	0,03	0,04	0,04	0,05	0,06	0,07
		P.7	Ferritic / martensitic stainless steel	< 1000	110-180	0,02	0,03	0,03	0,05	0,06	0,07	0,08	0,09	0,1	0,12
M	Stainless steel	M.1	Austenitic	< 850	60-120	0,02	0,02	0,03	0,03	0,04	0,05	0,05	0,06	0,07	0,08
		M.2	Ferritic-austenitic (Duplex)	< 1000	50-100	0,02	0,02	0,03	0,03	0,04	0,05	0,05	0,06	0,07	0,08
K	Cast iron	K.1	Grey cast iron	< 1000	70-150	0,03	0,04	0,04	0,06	0,07	0,08	0,09	0,11	0,12	0,15
		K.2	Nodular cast iron	< 1000	100-250	0,03	0,04	0,04	0,06	0,07	0,08	0,09	0,11	0,12	0,15
		K.3	Austempered ductile iron (ADI)	< 1400	70-120	0,03	0,03	0,03	0,04	0,05	0,06	0,07	0,08	0,09	0,1
N	Aluminium alloys	N.1	Pure aluminium	< 300	150-350	0,03	0,04	0,04	0,06	0,07	0,08	0,09	0,11	0,12	0,15
		N.2	Aluminium alloys Si < 0,5% (long chipping)	< 500	150-350	0,03	0,04	0,04	0,06	0,07	0,08	0,09	0,11	0,12	0,15
		N.3	Aluminium alloys Si < 10% (medium chipping)	< 500	150-350	0,03	0,04	0,04	0,06	0,07	0,08	0,09	0,11	0,12	0,15
		N.4	Aluminium alloys Si > 10% (short chipping)	< 600	100-250	0,02	0,02	0,03	0,03	0,04	0,05	0,05	0,06	0,07	0,08
	Copper alloys	N.5	Pure copper	250 - 350	150-350	0,03	0,04	0,04	0,06	0,07	0,08	0,09	0,11	0,12	0,15
		N.6	Copper alloys, Brass (long chipping)	< 700	150-350	0,03	0,04	0,04	0,06	0,07	0,08	0,09	0,11	0,12	0,15
		N.7	Copper alloys, Brass (short chipping)	< 700	100-250	0,02	0,02	0,03	0,03	0,04	0,05	0,05	0,06	0,07	0,08
		N.8	High strength bronze	700 - 1500	90-140	0,02	0,02	0,02	0,02	0,03	0,04	0,04	0,05	0,06	0,07
	Magnesium alloys	N.9	Pure Magnesium / Magnesium alloys	120 - 300	150-350	0,03	0,04	0,04	0,06	0,07	0,08	0,09	0,11	0,12	0,15
		N.10	High strength Magnesium alloys	240 - 400	150-350	0,03	0,04	0,04	0,06	0,07	0,08	0,09	0,11	0,12	0,15
S	Titanium alloys	S.1	Pure titanium	400 - 600	20-90	0,02	0,02	0,02	0,03	0,04	0,04	0,04	0,05	0,05	0,05
		S.2	Titanium alloys	600 - 1000	20-80	0,02	0,02	0,02	0,03	0,03	0,03	0,03	0,04	0,04	0,04
	Nickel alloys	S.3	Pure nickel	400 - 600	20-90	0,02	0,02	0,02	0,03	0,04	0,04	0,04	0,05	0,05	0,05
		S.4	Nickel alloys	600 - 1000	20-80	0,02	0,02	0,02	0,03	0,03	0,03	0,03	0,04	0,04	0,04

APPLICATION AND CUTTING SPEED TABLE

VR40 - VR45

ISO 513	Material	Group	Application	N/mm ²	Vc m/min	Feed (mm/tooth)															
						Ø1	Ø1,5	Ø2	Ø3	Ø4	Ø5	Ø6	Ø7	Ø8	Ø9	Ø10	Ø12	Ø14	Ø16		
P	Steel	P.1	Mild / magnetic steel	200 - 400	60-120	0,04	0,05	0,05	0,07	0,09	0,11	0,13	0,14	0,15	0,16	0,16	0,17	0,18	0,18		
		P.2	Construction steel, case hardening steel	350 - 700	60-120	0,04	0,05	0,05	0,07	0,09	0,11	0,13	0,14	0,15	0,16	0,16	0,17	0,18	0,18		
		P.3	Carbon steel	350 - 850	60-120	0,04	0,05	0,05	0,07	0,09	0,11	0,13	0,14	0,15	0,16	0,16	0,17	0,18	0,18		
		P.4	Alloyed steel, tempered steel	500 - 850	60-90	0,03	0,04	0,05	0,06	0,08	0,09	0,1	0,12	0,13	0,14	0,14	0,16	0,17	0,18		
		P.5	Alloyed steel, tempered steel	850 - 1200	50-80	0,03	0,04	0,04	0,05	0,05	0,06	0,07	0,07	0,08	0,09	0,1	0,12	0,13	0,14		
		P.6	Alloyed steel / high strength steel	1200 - 1600	50-70	0,02	0,02	0,02	0,03	0,04	0,05	0,06	0,06	0,07	0,08	0,09	0,1	0,12	0,13		
		P.7	Ferritic / martensitic stainless steel	< 1000	60-90	0,03	0,04	0,05	0,06	0,08	0,09	0,1	0,12	0,13	0,14	0,14	0,16	0,17	0,18		
M	Stainless steel	M.1	Austenitic	< 850	60-90	0,02	0,03	0,03	0,04	0,05	0,06	0,06	0,07	0,08	0,09	0,1	0,11	0,12	0,13		
		M.2	Ferritic-austenitic (Duplex)	< 1000	50-80	0,02	0,03	0,03	0,04	0,05	0,06	0,06	0,07	0,08	0,09	0,1	0,11	0,12	0,13		
K	Cast iron	K.1	Grey cast iron	< 1000	40-80	0,04	0,05	0,05	0,07	0,09	0,11	0,13	0,14	0,15	0,16	0,16	0,17	0,18	0,18		
		K.2	Nodular cast iron	< 1000	60-120	0,04	0,05	0,05	0,07	0,09	0,11	0,13	0,14	0,15	0,16	0,16	0,17	0,18	0,18		
		K.3	Austempered ductile iron (ADI)	< 1400	40-70	0,04	0,04	0,04	0,05	0,05	0,06	0,07	0,08	0,09	0,1	0,11	0,12	0,12	0,12		
N	Aluminium alloys	N.1	Pure aluminium	< 300	100-200	0,04	0,05	0,05	0,07	0,09	0,11	0,13	0,14	0,15	0,16	0,16	0,17	0,18	0,18		
		N.2	Aluminium alloys Si < 0,5% (long chipping)	< 500	100-200	0,04	0,05	0,05	0,07	0,09	0,11	0,13	0,14	0,15	0,16	0,16	0,17	0,18	0,18		
		N.3	Aluminium alloys Si < 10% (medium chipping)	< 500	100-200	0,04	0,05	0,05	0,07	0,09	0,11	0,13	0,14	0,15	0,16	0,16	0,17	0,18	0,18		
		N.4	Aluminium alloys Si > 10% (short chipping)	< 600	60-140	0,03	0,03	0,03	0,04	0,05	0,06	0,06	0,07	0,08	0,09	0,1	0,11	0,13	0,14		
	Copper alloys	N.5	Pure copper	250 - 350	100-200	0,04	0,05	0,05	0,07	0,09	0,11	0,13	0,14	0,15	0,16	0,16	0,17	0,18	0,18		
		N.6	Copper alloys, Brass (long chipping)	< 700	100-200	0,04	0,05	0,05	0,07	0,09	0,11	0,13	0,14	0,15	0,16	0,16	0,17	0,18	0,18		
		N.7	Copper alloys, Brass (short chipping)	< 700	60-140	0,03	0,03	0,03	0,04	0,05	0,06	0,06	0,07	0,08	0,09	0,1	0,11	0,13	0,14		
		N.8	High strength bronze	700 - 1500	60-100	0,03	0,03	0,03	0,03	0,04	0,04	0,05	0,05	0,06	0,08	0,08	0,09	0,09	0,1		
	Magnesium alloys	N.9	Pure Magnesium / Magnesium alloys	120 - 300	100-200	0,04	0,05	0,05	0,07	0,09	0,11	0,13	0,14	0,15	0,16	0,16	0,17	0,18	0,18		
		N.10	High strength Magnesium alloys	240 - 400	100-200	0,04	0,05	0,05	0,07	0,09	0,11	0,13	0,14	0,15	0,16	0,16	0,17	0,18	0,18		
S	Titanium alloys	S.1	Pure titanium	400 - 600	20-50	0,03	0,03	0,03	0,04	0,05	0,06	0,06	0,06	0,07	0,07	0,08	0,08	0,08			
		S.2	Titanium alloys	600 - 1000	20-40	0,03	0,03	0,03	0,04	0,04	0,05	0,06	0,06	0,06	0,07	0,07	0,07	0,08	0,08		
	Nickel alloys	S.3	Pure nickel	400 - 600	20-50	0,03	0,03	0,03	0,04	0,05	0,06	0,06	0,06	0,07	0,07	0,08	0,08	0,08	0,08		
		S.4	Nickel alloys	600 - 1000	20-40	0,03	0,03	0,03	0,04	0,04	0,05	0,06	0,06	0,06	0,07	0,07	0,07	0,08	0,08		

APPLICATION AND CUTTING SPEED TABLE

VR50 - VR55																			
ISO 513	Material	Group	Application	N/mm ²	V _c m/min	Feed (mm/tooth)													
						Ø1	Ø1,5	Ø2	Ø3	Ø4	Ø5	Ø6	Ø7	Ø8	Ø9	Ø10	Ø12	Ø14	Ø16
S	Titanium alloys	S.2	Titanium alloys	600 - 1000	20-40	0,03	0,03	0,03	0,04	0,04	0,05	0,06	0,06	0,06	0,07	0,07	0,07	0,08	0,08
	Nickel alloys	S.4	Nickel alloys	600 - 1000	20-40	0,03	0,03	0,03	0,04	0,04	0,05	0,06	0,06	0,06	0,07	0,07	0,07	0,08	0,08
H	Hardened materials	H.1	Alloyed steel, hardness HRC 44-55	-	50-60	0,02	0,03	0,03	0,04	0,04	0,05	0,05	0,06	0,06	0,07	0,07	0,08	0,09	0,1
		H.2	Alloyed steel, hardness HRC 56-62	-	40-50	0,01	0,02	0,02	0,03	0,03	0,04	0,05	0,05	0,06	0,06	0,06	0,07	0,08	0,09

PROCESS DESCRIPTION

VR10 - VR20 - VR30

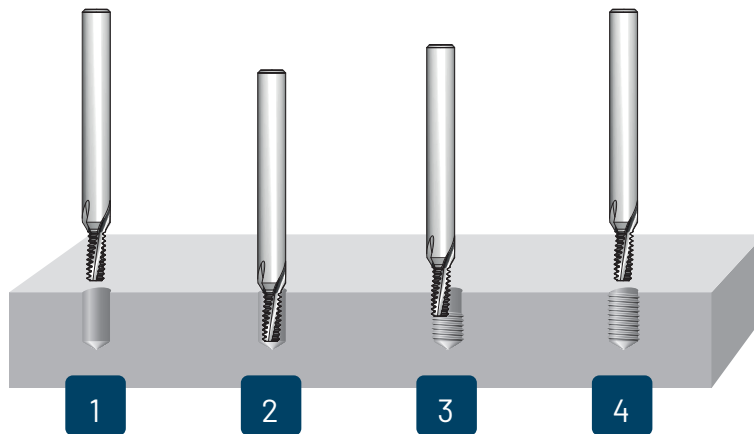

- 1 Start point - center position
- 2 Axial movement down to required thread depth, then 45° arc entrance
- 3 Thread milling (360°)
- 4 45° arc exit, then axial movement to start point

VR40 - VR45 - VR50 - VR55

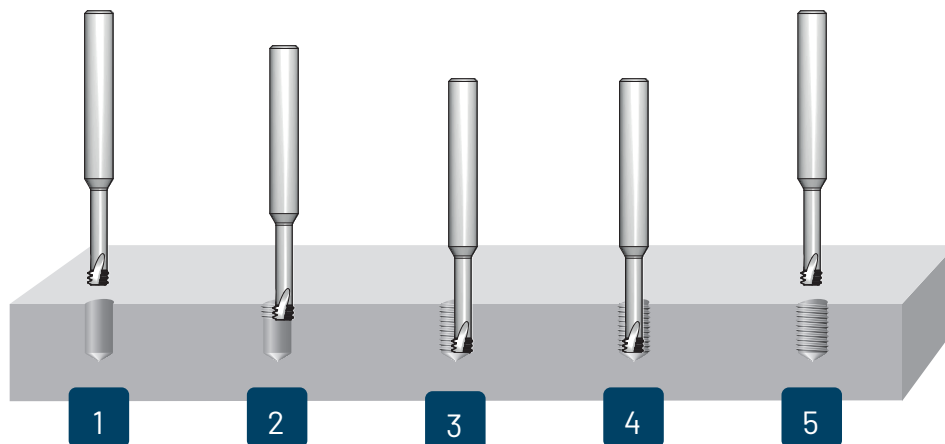

- 1 Start point - center position
- 2 45° arc entrance
- 3 Thread milling to required thread depth
- 4 45° arc exit
- 5 Axial movement to start point

INT HM

VR10
TiAlN

VR20
TiAlN

VR30
TiAlN

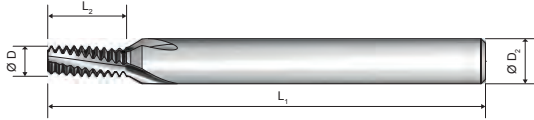

APPLICATION RANGE			
ISO	VR10 TiAlN	VR20 TiAlN	VR30 TiAlN
P	•	•	•
M	•	•	•
K	•	•	•
N	•	•	•
S	•	•	•

For cutting data see page 212

P	M	MF	ØD ₂ h6	ØD	z	L ₂	L ₁	VR10 TiAlN	VR20 TiAlN	VR30 TiAlN
[mm]			[mm]	[mm]	[-]	[mm]	[mm]			
0,5		M5x0,5	6	3,8	3	10,3	58	VR1003810501000		
0,7	M4		6	3,1	3	7,4	58	VR1003110700700	VR2003110700700	
0,75		M6x0,75	6	4,5	3	10,1	58		VR2004510751000	
0,8	M5		6	3,6	3	9,2	58	VR1003610800900	VR2003810800900	
1	M6		6	4	3	10,5	58	VR1004011001000		
1	M6		6	4	3	14,5	58	VR1004011001400		
1	M6/M7		6	4,6	3	14,5	58			VR3004811001000
1		M10x1	8	8	4	16,5	64	VR1008011001600	VR2008011001600	VR3008011001600
1		M12x1	10	10	4	24,5	73		VR2010011002400	
1,25	M8	M10x1,25	6	5	3	14,4	58	VR1005011251400		
1,25	M8	M10x1,25	6	6	3	14,4	58		VR2006011251400	
1,25	M8	M10x1,25	6	5	3	19,4	58	VR1005011251900		
1,25	M8	M10x1,25	6	6	3	19,4	58		VR2006011251900	VR3006011251900
1,5	M10	M12x1,5	8	7	3	17,3	64	VR1007011501700		
1,5	M10	M12x1,5	8	7	3	24,8	76	VR1007011502400		
1,5	M10	M12x1,5	8	7,8	3	17	64		VR2007811501700	VR3007811501700
1,5		M14x1,5	10	10	4	21,8	73	VR1010011502100		VR3010011502100
1,5		M16x1,5	12	12	4	26,3	84		VR2012011502600	VR3012011502600
1,75	M12		8	8	3	20,1	64	VR1008011752000		
1,75	M12		10	9	3	20,1	73		VR2009011752000	
2	M16		12	11,8	4	27	84		VR2011812002700	
2,5	M20		16	15	5	48,8	105		VR2015012504800	
3	M24		20	18	4	58,5	120		VR2018013005800	

VR SERIES

INT HM

VR40
TiAlN

VR45
TiAlN

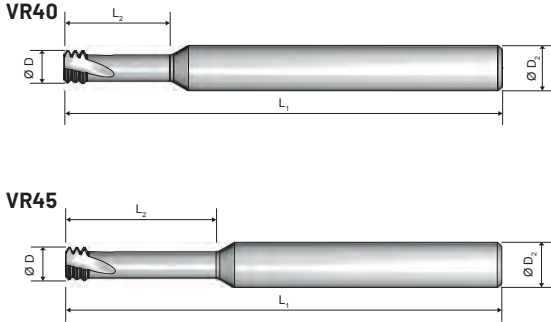

INT

INT



APPLICATION RANGE			
ISO	VR40 TiAlN	VR45 TiAlN	
P	•	•	
M	•	•	
K	•	•	
N	•	•	
S	•	•	

For cutting data see page 213

P	M	ØD ₂ h6	ØD	z	L ₂	L ₁	VR40 TiAlN	VR45 TiAlN
[mm]		[mm]	[mm]	[-]	[mm]	[mm]		
0,3	M1,4	3	1,05	3	4	39		VR4501010300400
0,35	M1,6	3	1,2	3	4,8	39		VR4501210350400
0,4	M2	6	1,53	3	4,5	58	VR4001510400400	
0,4	M2	3	1,53	3	6	39		VR4501510400600
0,5	M3	6	2,37	3	6,5	58	VR4002310500600	
0,5	M3	6	2,37	3	9,5	58		VR4502310500900
0,5	M3	6	2,37	3	9,5	105		VR450231050090L
0,7	M4	6	3,1	3	9	58	VR4003110700900	
0,7	M4	6	3,1	3	12,5	58		VR4503110701200
0,7	M4	6	3,1	3	12,5	105		VR450311070120L
0,8	M5	6	3,8	3	12,5	58	VR4003810801200	
0,8	M5	6	3,8	3	16	58		VR4503810801600
0,8	M5	6	3,8	3	16	105		VR450381080160L
1	M6	6	4,65	3	14	58	VR4004611001400	
1	M6	6	4,65	3	20	58		VR4504611002000
1	M6	6	4,65	3	20	105		VR450461100200L
1,25	M8	6	5,95	3	18	58	VR4005911251800	
1,25	M8	6	6	3	24	58		VR4506011252400
1,5	M10	8	7,8	3	23	64	VR4007811502300	
1,75	M12	10	9	3	26	73	VR4009011752600	
2	M16	12	11,8	4	35	84	VR4011812003500	

INT

HM

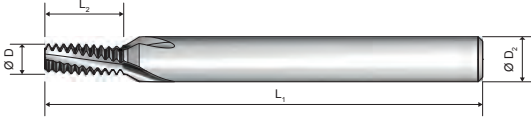
VR10
TiAlNVR20
TiAlN

INT

INT



APPLICATION RANGE

ISO	VR10 TiAlN	VR20 TiAlN
P	•	•
M	•	•
K	•	•
N	•	•
S	•	•

For cutting data see page 212

P (Sp/1")	UNC	UNF	ØD ₂ h6 [mm]	ØD [mm]	z [-]	L ₂ [mm]	L ₁ [mm]	VR10 TiAlN	VR20 TiAlN
28		1/4"	6	4	3	11,3	58	VR10040U28T1100	
28		1/4"	6	5	3	11,3	58		VR20050U28T1100
24		5/16"	6	5	3	14,3	58	VR10050U24T1400	
24		3/8"	8	7	3	20,6	64	VR10070U24T2000	
24		5/16"	8	6,6	3	14,3	64		VR20066U24T1400
24		3/8"	8	8	4	20,6	64		VR20080U24T2000
20	1/4"		6	4,5	3	12,1	58	VR10045U20T1200	
20		7/16"-1/2"	8	7	3	21	64	VR10070U20T2100	
20	1/4"		6	4,7	3	12,1	58		VR20047U20T1200
20		7/16"	8	8	3	21	64		VR20080U20T2100
20		1/2"	10	10	4	22,3	73		VR20100U20T2200
18	5/16"		6	5	3	14,8	58	VR10050U18T1400	
18	5/16"		6	5,6	3	14,8	58		VR20056U18T1400
16	3/8"		6	6	3	16,7	58	VR10060U16T1600	
16	3/8"		8	6,7	3	16,7	64		VR20067U16T1600
14	7/16"		8	7	3	20,9	64	VR10070U14T2000	
14	7/16"		8	7,7	3	20,9	64		VR20077U14T2000
13	1/2"		8	8	3	22,5	64	VR10080U13T2200	
13	1/2"		10	9,2	3	22,5	73		VR20092U13T2200
11	5/8"		10	10	3	28,9	73	VR10100U11T2800	
11	5/8"		12	11,4	3	28,9	84		VR20114U11T2800

INT HM

VR40
TiAlN

VR45
TiAlN

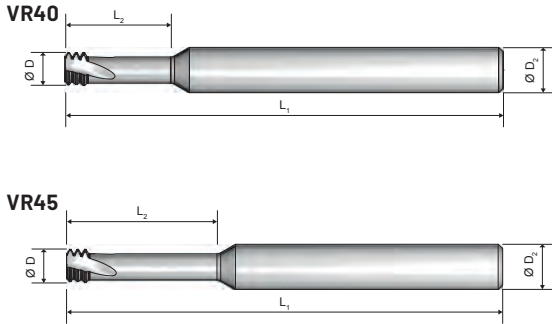

APPLICATION RANGE			
ISO	VR40 TiAlN	VR45 TiAlN	
P	•	•	
M	•	•	
K	•	•	
N	•	•	
S	•	•	

For cutting data see page 213

INT INT

2xD 3xD

RH RH

P(Sp/1")	UNC	UNF	ØD ₂ h6 [mm]	ØD [mm]	z	L ₂ [mm]	L ₁ [mm]	VR40 TiAlN	VR45 TiAlN
28		1/4"	6	5	3	14,5	58	VR40050U28T1400	
28		1/4"	6	5	3	19	58		VR45050U28T1900
24		5/16"-3/8"	8	6,6	3	17	64	VR40066U24T1700	
24		5/16"-3/8"	8	6,6	3	24	64		VR45066U24T2400
20	1/4"		6	4,75	3	14	58	VR40047U20T1400	
20		7/16"	8	8	3	25	64	VR40080U20T2500	
20	1/4"		6	4,75	3	19	58		VR45047U20T1900
18	5/16"		6	6	3	17	58	VR40060U18T1700	
18		5/8"	12	12	4	35	84	VR40120U18T3500	
18	5/16"		6	6	3	23	58		VR45060U18T2300
16	3/8"		8	6,7	3	22	64	VR40067U16T2200	
14	7/16"		8	7,7	3	25	64	VR40077U14T2500	
13	1/2"		10	9,2	3	27,5	73	VR40092U13T2700	
11	5/8"		12	11,4	3	34,5	84	VR40114U11T3400	

VR SERIES



INT

HM

VR50
TiAlN

VR55
TiAlN

VR50

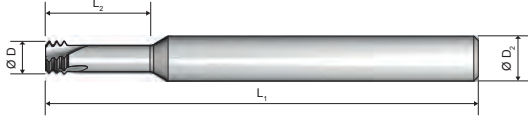

VR55

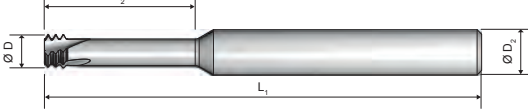

APPLICATION RANGE

ISO	VR50 TiAlN	VR55 TiAlN
S	•	•
H	•	•

For cutting data see page 214

INT

INT

2xD

3xD

LH

LH

P (Sp/1")	UNC	UNF	ØD ₂ h6 [mm]	ØD [mm]	z [-]	L ₂ [mm]	L ₁ [mm]	VR50 TiAlN	VR55 TiAlN
28		1/4"	6	5	3	14,5	58	VR50050U28T1400	
28		1/4"	6	5	3	19	58		VR55050U28T1900
24		5/16"-3/8"	8	6,6	3	17	64	VR50066U24T1700	
24		5/16"-3/8"	8	6,6	3	24	64		VR55066U24T2400
20	1/4"		6	4,75	3	14	58	VR50047U20T1400	
20		7/16"	8	8	3	25	64	VR50080U20T2500	
20	1/4"		6	4,75	3	19	58		VR55047U20T1900
18	5/16"		6	6	3	17	58	VR50060U18T1700	
18		5/8"	12	12	4	35	84	VR50012U18T3500	
18	5/16"		6	6	3	23	58		VR55060U18T2300
16	3/8"		8	6,7	3	22	64	VR50067U16T2200	
14	7/16"		8	7,7	3	25	64	VR50077U14T2500	
13	1/2"		10	9,2	3	27,5	73	VR50092U13T2700	
11	5/8"		12	11,4	3	34,5	84	VR50114U11T3400	



VA SERIES

SYNCHRONOUS TAPPING ATTACHMENTS



TAPPING ATTACHMENTS

Vergnano Sincro synchronous tapping attachments are specifically designed to enhance the performance of the Vergnano S-Series taps for synchronous tapping processes.

Synchronous Tapping Attachments

In modern CNC machine tools with synchronous spindles, the rotational and axial movements of the spindle are coordinated by the numeric control of the machine. On these modern machine tools standard compensated tapping attachments are not recommended since the large compensation in extension can negatively influence the performance of the tool. Vergnano Sincro synchronous tapping attachments are specifically designed for synchronous tapping: micro-compensation reduces the axial and radial forces generated during the tapping process and enhances tool life. Since machine, tapping attachment and tool are synchronised it is possible to reach high machining speeds. This advantage, together with increased tool life, leads to improved productivity.

Quick-Change System

Vergnano offers a new system consisting in tapping attachment and quick-change adaptor which allows worn tools to be substituted without changing the entire tapping attachment thereby saving precious machining time.

It is recommended to have a second quick-change adaptor (in addition to that delivered with the tapping attachment) sold separately to exploit this advantage.

Also available are extended quick-change adaptors which permit extension of the tapping attachment in order to reach threads in difficult positions.

This versatile and cost-saving system covers a wide range of applications with just one tapping attachment.

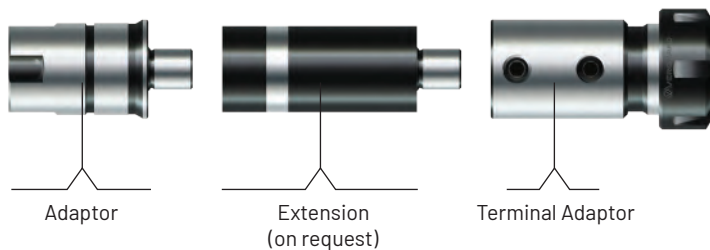

The extended adapter is sold assembled and consists of two parts (adaptor and terminal adaptor). Further extensions are available on request.

Micro-Compensation

During tap reversal high axial forces are generated on the tap which cause mechanical stresses and micro-wear. This in turn leads to reduced tool life and tool precision. For this reason Vergnano synchronous tapping attachments are designed with differential micro-compensation in traction and compression which compensates the stresses on the tap.

Compensation in traction (1 mm) is obtained by steel springs which guarantee greater reliability while compensation in compression (0,2 mm) is obtained by elastomer rings.

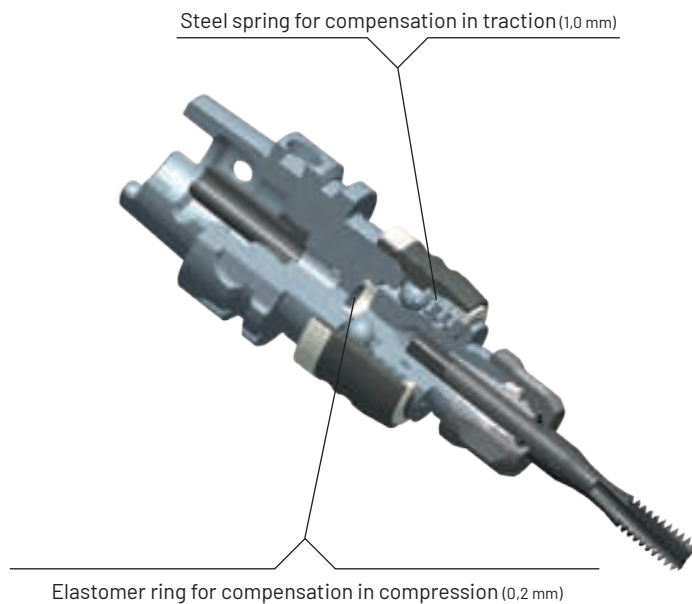

Through Coolant Capability

All Vergnano synchronous tapping attachments are designed for use with internal lubrication up to 50 bars. For higher values a special pressure-tight nut screw is available on request.

The special attachment design forces the through coolant to enter the tap adaptor from the sides without interfering with the compensation length.



SYNCHRONOUS ER TAPPING ATTACHMENT with QUICK-CHANGE TAP ADAPTOR
With internal through coolant capability (1)



DIN 69893 HSK A

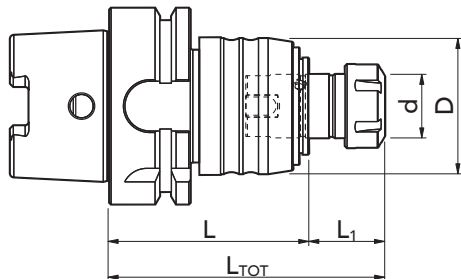

Article Code	Attachment	Tap Size	L [mm]	ø D [mm]	ø d [mm]	ER collet	L ₁ [mm]	L _{TOT} [mm]
VA01A06302CH160	HSK-A63	M3 - M8	64	43	20	ER 16	20,5	84,5
VA01A06302CH250	HSK-A63	M6 - M20	97	60	32	ER 25	23,5	120,5
VA01A10002CH400	HSK-A100	M14 - M33	115	87	50	ER 40	28,5	143,5

SYNCHRONOUS ER TAPPING ATTACHMENT with QUICK-CHANGE TAP ADAPTOR
With internal through coolant capability (1)



DIN 1835 B+E

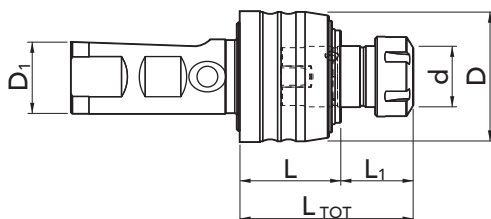

Article Code	Attachment ø D ₁ [mm]	Tap Size	L [mm]	ø D [mm]	ø d [mm]	ER collet	L ₁ [mm]	L _{TOT} [mm]
VA01C02502CH160	25	M3 - M8	34	43	20	ER 16	20,5	54,5
VA01C02502CH250	25	M6 - M20	56	60	32	ER 25	23,5	79,5
VA01C04002CH400	40	M14 - M33	80	87	50	ER 40	28,5	108,5

(1) For coolant pressure above 50 bars a special nut screw is available on request

SYNCHRONOUS ER TAPPING ATTACHMENT with QUICK-CHANGE TAP ADAPTOR
With internal through coolant capability (1)



SK DIN 69871 AD

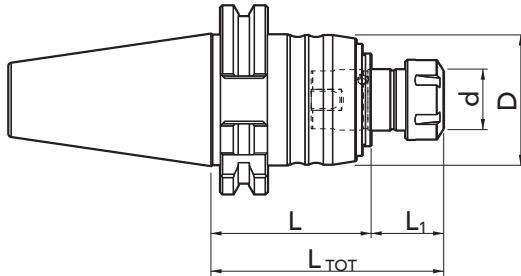

Article Code	Attachment	Tap Size	L [mm]	ø D [mm]	ø d [mm]	ER collet	L ₁ [mm]	L _{TOT} [mm]
VA01B04002CH160	SK 40 AD	M3 - M8	53	43	20	ER 16	20,5	73,5
VA01B05002CH160	SK 50 AD	M3 - M8	53	43	20	ER 16	20,5	73,5
VA01B04002CH250	SK 40 AD	M6 - M20	90	60	32	ER 25	23,5	113,5
VA01B05002CH250	SK 50 AD	M6 - M20	74	60	32	ER 25	23,5	97,5

SYNCHRONOUS ER TAPPING ATTACHMENT with QUICK-CHANGE TAP ADAPTOR
With internal through coolant capability (1)



SK DIN 69871 AD+B

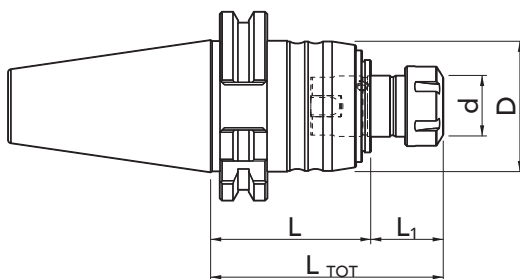

Article Code	Attachment	Tap Size	L [mm]	ø D [mm]	ø d [mm]	ER collet	L ₁ [mm]	L _{TOT} [mm]
VA01B05002CH400	SK 50 B	M14 - M33	115	87	50	ER 40	28,5	143,5

(1) For coolant pressure above 50 bars a special nut screw is available on request

SYNCHRONOUS ER TAPPING ATTACHMENT with QUICK-CHANGE TAP ADAPTOR
With internal through coolant capability (1)



MAS 403 BT

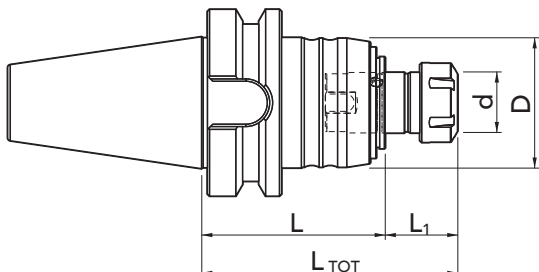

Article Code	Attachment	Tap Size	L [mm]	ø D [mm]	ø d [mm]	ER collet	L ₁ [mm]	L _{TOT} [mm]
VA01M04002CH160	BT 40	M3 - M8	61	43	20	ER 16	20,5	81,5
VA01M05002CH160	BT 50	M3 - M8	72	43	20	ER 16	20,5	92,5
VA01M04002CH250	BT 40	M6 - M20	82	60	32	ER 25	23,5	105,5
VA01M05002CH250	BT 50	M6 - M20	93	60	32	ER 25	23,5	116,5

SYNCHRONOUS ER TAPPING ATTACHMENT with QUICK-CHANGE TAP ADAPTOR
With internal through coolant capability (1)



MAS 403 BT - B

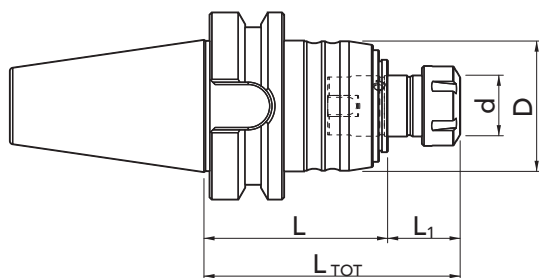

Article Code	Attachment	Tap Size	L [mm]	ø D [mm]	ø d [mm]	ER collet	L ₁ [mm]	L _{TOT} [mm]
VA01M05002CH400	BT 50 B	M14 - M33	124	87	50	ER 40	28,5	152,5

(1) For coolant pressure above 50 bars a special nut screw is available on request

SYNCHRONOUS ER TAPPING ATTACHMENT with QUICK-CHANGE TAP ADAPTOR
With internal through coolant capability(1)



POLIGONAL Attachment ISO 26623-1

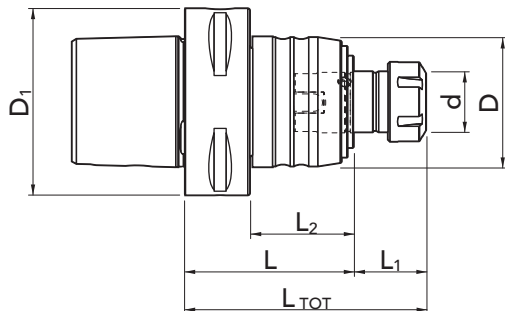

Article Code	Attachment $\varnothing D_1$ [mm]	Tap Size	L [mm]	L ₂ [mm]	$\varnothing D$ [mm]	$\varnothing d$ [mm]	ER collet	L ₁ [mm]	L _{TOT} [mm]
VA01P04002CH160	C40	M3 - M8	55	35	43	20	ER 16	20,5	75,5
VA01P05002CH160	C50	M3 - M8	55	35	43	20	ER 16	20,5	75,5
VA01P06302CH160	C63	M3 - M8	57	35	43	20	ER 16	20,5	77,5
VA01P08002CH160	C80	M3 - M8	66	36	43	20	ER 16	20,5	86,5
VA01P04002CH250	C40	M6 - M20	75	55	60	32	ER 25	23,5	98,5
VA01P05002CH250	C50	M6 - M20	75	55	60	32	ER 25	23,5	98,5
VA01P06302CH250	C63	M6 - M20	77	55	60	32	ER 25	23,5	100,5
VA01P08002CH250	C80	M6 - M20	86	56	60	32	ER 25	23,5	109,5
VA01P08002CH400	C80	M14 - M33	116	86	87	50	ER 40	28,5	144,5

(1) For coolant pressure above 50 bars a special nut screw is available on request

QUICK-CHANGE TAP ADAPTOR

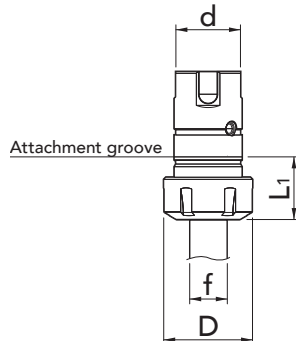

Article Code	Tap Size	Shaft \varnothing f [mm]	\varnothing d [mm]	\varnothing D [mm]	L ₁ [mm]	ER collet
*CHADAP160310000	M3 - M8	3 - 8	20	28	20,5	ER 16
CHADAP250316000	M6 - M20	3 - 16	32	42	23,5	ER 25
CHADAP400626000	M14 - M33	6 - 25	50	63	28,5	ER 40

EXTENDED QUICK-CHANGE TAP ADAPTOR

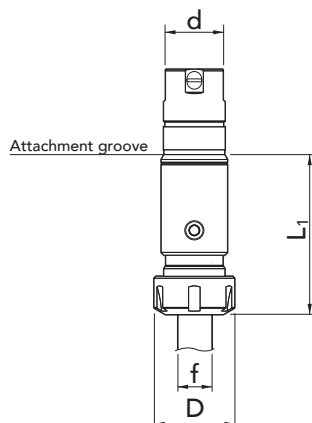

Article Code	Tap Size	Shaft \varnothing f [mm]	\varnothing d [mm]	\varnothing D [mm]	L ₁ [mm]	ER collet
*CHEXAD160310000	M3 - M8	3 - 8	20	28	51,5	ER 16
CHEXAD250316000	M6 - M20	3 - 16	32	42	80,5	ER 25
CHEXAD400626000	M14 - M33	6 - 25	50	63	90,5	ER 40

* Hexagonal nut screw

DIN 6499

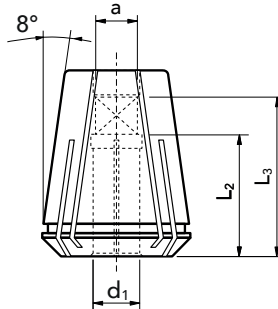

Article Code	ER collet	$\varnothing d_1$ [mm]	a [mm]	L_2 [mm]	L_3 [mm]
SLERGB160103500	ER 16	3,5	2,7	18	24
SLERGB160104500	ER 16	4,5	3,4	18	24
SLERGB160105500	ER 16	5,5	4,3	18	25
SLERGB160106000	ER 16	6	4,9	18	26
SLERGB160107000	ER 16	7	5,5	18	26
SLERGB160108000	ER 16	8	6,2	22	31
SLERGB250103500	ER 25	3,5	2,7	18	24
SLERGB250104500	ER 25	4,5	3,4	18	24
SLERGB250105500	ER 25	5,5	4,3	18	25
SLERGB250106000	ER 25	6	4,9	18	26
SLERGB250107000	ER 25	7	5,5	18	26
SLERGB250108000	ER 25	8	6,2	22	31
SLERGB250109000	ER 25	9	7	22	32
SLERGB250110000	ER 25	10	8	25	36
SLERGB250111000	ER 25	11	9	25	37
SLERGB250112000	ER 25	12	9	25	37
SLERGB250114000	ER 25	14	11	25	39
SLERGB250116000	ER 25	16	12	25	40
SLERGB400106000	ER 40	6	4,9	18	26
SLERGB400107000	ER 40	7	5,5	18	26
SLERGB400108000	ER 40	8	6,2	22	31
SLERGB400109000	ER 40	9	7	22	32
SLERGB400110000	ER 40	10	8	25	36
SLERGB400111000	ER 40	11	9	25	37
SLERGB400112000	ER 40	12	9	25	37
SLERGB400114000	ER 40	14	11	25	39
SLERGB400116000	ER 40	16	12	25	40
SLERGB400118000	ER 40	18	14,5	25	42
SLERGB400120000	ER 40	20	16	28	47
SLERGB400122000	ER 40	22	18	28	49
SLERGB400125000	ER 40	25	20	33	56

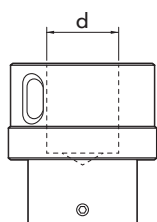

Article Code	ER collet	Ø d [mm]				
ASCHADAP1620000	ER 16	20				
ASCHADAP2532000	ER 25	32				
ASCHADAP4050000	ER 40	50				

WRENCH for nut screw



Article Code	Nut Screw	ER collet				
KE02ER160200000	Esagonale	ER 16				
KE04ER250200000	Standard	ER 25				
KE04ER400200000	Standard	ER 40				

TIGHTENING TORQUE TABLE

It is recommended to tighten the nut screws with the torque values shown in the table below.

Article Code	Torque [Nm]
ER 16	45
ER 25	70
ER 40	150



TECHNICAL INFORMATION

Tap terminology

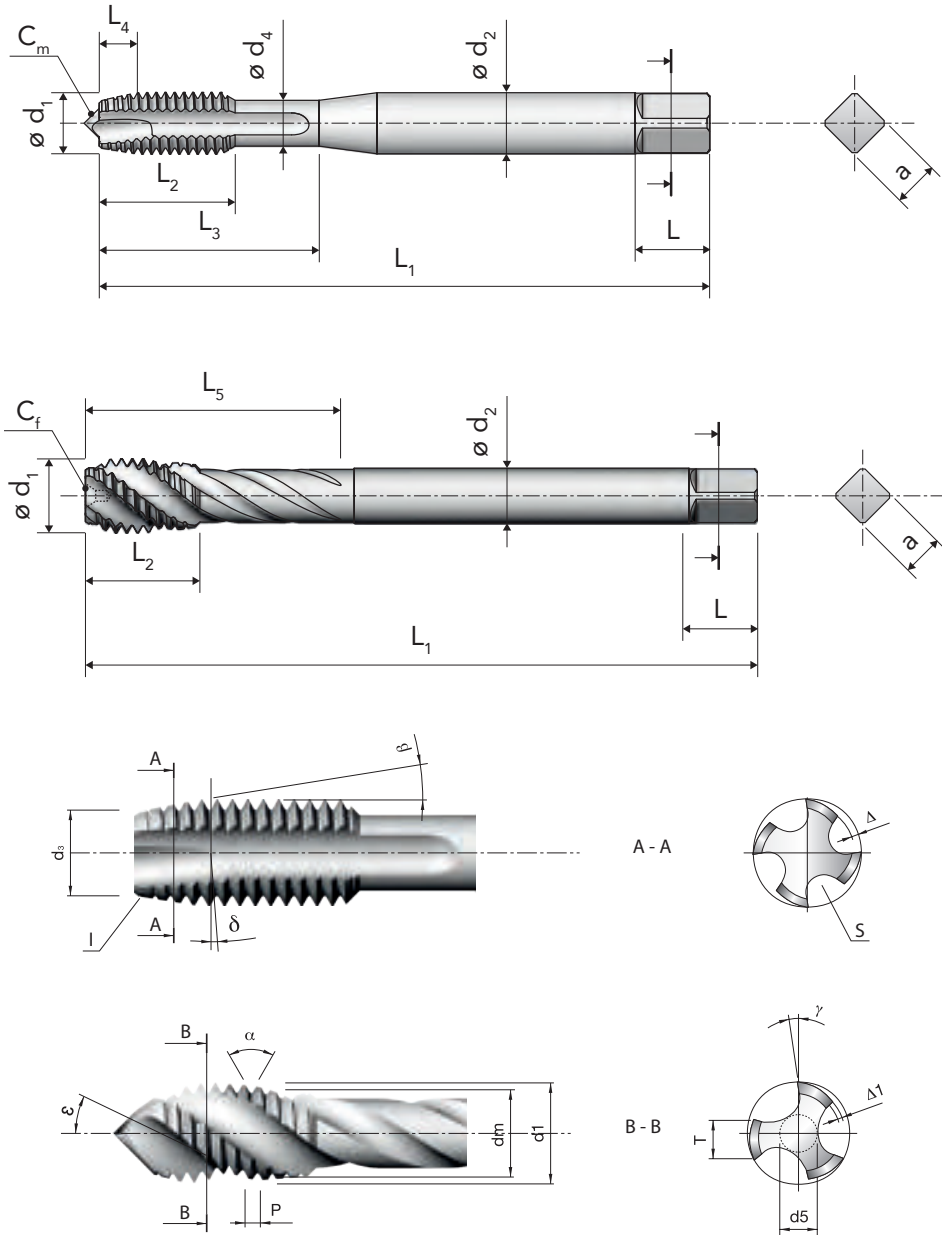

d_1 Nominal diameter

the diameter used for the purpose of general identification.

d_m Pitch diameter

the diameter measured where the width of the thread is equal to half the pitch.

d_2 Shank diameter

the diameter of the shank, important for the tapping attachment.

d_3 Chamfer diameter

the diameter at the leading end of the chamfer.

d_4 Neck diameter

the diameter of the reduced section between the thread and shank of the tap.

d_5 Core diameter

the diameter of a circle tangent to the bottom of the flutes.

l Chamfer

the taper on the threads at the front end of the tap made by grinding and relieving the crests of the first few teeth.

a Square

the square with rounded corners formed by four flats parallel to the tap axis. The square serves to drive the tap.

Tap terminology

L

Square length

the length of the flats that form the square.

L₁

Total length

the complete length of the tap from end to end, excluding external centres.

L₂

Thread length

the length of the threaded section of the tap.

L₃

Usable length

the length measured from the front end of the tap to the end of the neck section. This length determines the maximum threadable depth on taps with reinforced shank.

L₄

Chamfer length

the length of the chamfer measured parallel to the tap axis, excluding the chamfer bevel.

L₅

Flute length

the axial length of the flute including the cutter sweep.

C_m

External centre

the pointed end of the tap.

C_f

Internal centre

the countersink in one or both ends of the tap.

P

Pitch

the distance, measured parallel to the tap axis, between two corresponding and successive points on the thread profile.

α

Angle of thread

the angle between the flanks of the thread (measured in an axial plane).

δ

Thread lead angle

the angle made by the spiral of the thread and a plane perpendicular to the tap axis, measured on the pitch diameter line.

β

Chamfer angle

the angle between the chamfer and the tap axis, measured in an axial plane.

γ

Rake angle

the angle between the cutting face of the tap and a radial line passing through the crest of the tooth at the cutting edge.

T

Land width

the chordal width of material between two successive flutes.

S

Flute

the longitudinal channels in a tap which create cutting edges. The flutes provide space for chips and passage for coolant/lubricant.

Δ₁

Pitch diameter relief

the radial reduction of the pitch and/or major diameter behind the cutting edge of the tap. The relief confers cutting properties and provides clearance between the part being threaded and the tap threads.

Δ

Chamfer relief

the radial reduction of the major diameter on the tap chamfer behind the cutting edge. The chamfer relief confers cutting properties to the tap.

ε

Spiral flute angle

the angle formed by the flutes and the tap axis.

Die terminology

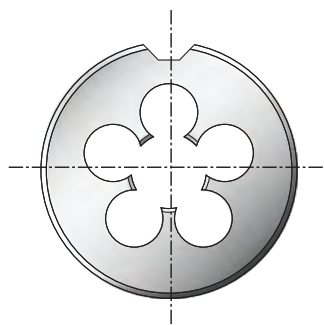
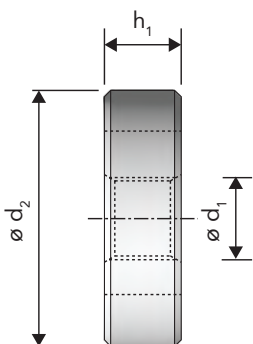

d₁

nominal diameter

d₂

outside diameter

h₁

thickness



Flute geometries

STRAIGHT FLUTES

These taps are used on steels with normal strength and toughness ($R=750 \text{ N/mm}^2$) as well as on short-chipping abrasive materials (grey cast iron, bronze, etc.).

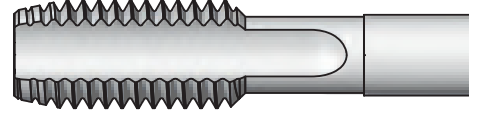

SPIRAL FLUTES, 15° Righthand Spiral

These taps improve chip evacuation and are well suited when tapping blind holes of medium depth on tough materials.

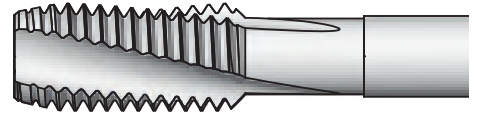

SPIRAL FLUTES, 40°/45° Righthand Spiral

The high helix angle ensures the evacuation of chips from deep blind holes.

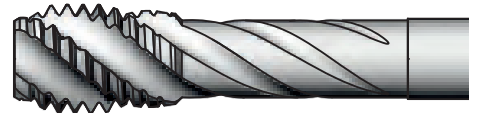

SPIRAL FLUTES, 40° Righthand Spiral, FOR LIGHT ALLOYS

The large flutes and high helix angle ensure efficient chip removal on long-chipping light alloys such as aluminium.

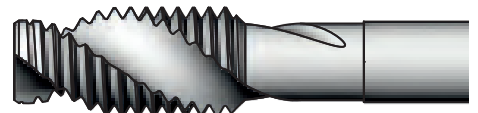



Flute geometries

STRAIGHT FLUTES WITH INTERRUPTED THREADS

For tapping soft and mild materials such as iron, aluminium etc. The interrupted threads avoid chips sticking to the thread flanks and consequent damage of the tap.

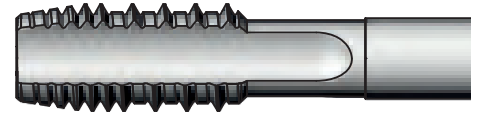

SPIRAL POINT

The spiral point or gun nose is produced by a high helix angle combined with an increased rake angle in the front area of the tap. This design ensures spontaneous chip evacuation in the feed direction.

This geometry is suitable when tapping through holes on materials which produce continuous chips.

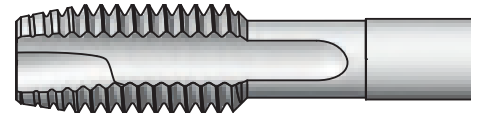

FORMING TAPS WITHOUT OIL GROOVES

These tools produce threads through plastic deformation of the workpiece material. No chips are produced during the tapping process.



FORMING TAPS WITH OIL GROOVES

The oil grooves improve lubrication in the chamfer area making these taps suitable for threading deep holes.

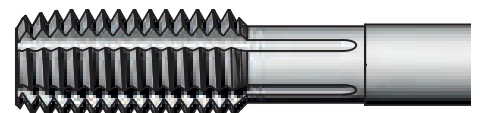

Types of chamfer forms

The types of chamfer are defined in standards DIN 2175 and DIN 2197 for forming taps and cutting taps, respectively.

	Form A	Form B	Form C	Form D	Form E	Form F
Chamfer form and length						
Flute type						

Types of centres

The tap manufacturer, according to the diameter and the application, defines the types of centres. Types of centre and chamfer are generally combined together as in the following table, but for specific applications exceptions are possible.

		Form A	Form B	Form C	Form D	Form E
 Male centre	M	$M2 \leq \emptyset \leq M8$	$M2 \leq \emptyset \leq M8$	$M2 \leq \emptyset \leq M8$	$M2 \leq \emptyset \leq M8$	-
	MF	$M2 \leq \emptyset \leq M6$	$M4 \leq \emptyset \leq M6$	$M2 \leq \emptyset \leq M6$	$M5 \leq \emptyset \leq M6$	-
	UNC	$Nr.2-56 \leq \emptyset \leq 1/4"-18$	$Nr.2-56 \leq \emptyset \leq 1/4"-18$	$Nr.2-56 \leq \emptyset \leq 1/4"-18$	$Nr.2-56 \leq \emptyset \leq 1/4"-18$	-
	UNF	$Nr.2-64 \leq \emptyset \leq 1/4"-28$	$Nr.2-64 \leq \emptyset \leq 1/4"-28$	$Nr.2-64 \leq \emptyset \leq 1/4"-28$	-	-
	G	-	-	-	-	-
 Half centre	M	$M8 < \emptyset \leq M10$	$M8 < \emptyset \leq M10$	$M8 < \emptyset \leq M10$	$M8 < \emptyset \leq M10$	-
	MF	$M6 < \emptyset \leq M10$	$M6 < \emptyset \leq M10$	$M6 < \emptyset \leq M10$	$M6 < \emptyset \leq M10$	-
	UNC	$5/16"-18 \leq \emptyset \leq 3/8"-16$	$5/16"-18 \leq \emptyset \leq 3/8"-16$	$5/16"-18 \leq \emptyset \leq 3/8"-16$	-	-
	UNF	$5/16"-24 \leq \emptyset \leq 3/8"-24$	$5/16"-24 \leq \emptyset \leq 3/8"-24$	$5/16"-24 \leq \emptyset \leq 3/8"-24$	-	-
	G	$\emptyset = 1/8"-28$	$\emptyset = 1/8"-28$	$\emptyset = 1/8"-28$	-	-
 Female centre	M	$\emptyset > M10$	$\emptyset > M10$	$\emptyset > M10$	$\emptyset > M10$	ALL SIZES
	MF	$\emptyset > M10$	$\emptyset > M10$	$\emptyset > M10$	$\emptyset > M10$	ALL SIZES
	UNC	$\emptyset \geq 7/16"-14$	$\emptyset \geq 7/16"-14$	$\emptyset \geq 7/16"-14$	$\emptyset \geq 5/16"-18$	ALL SIZES
	UNF	$\emptyset \geq 7/16"-20$	$\emptyset \geq 7/16"-20$	$\emptyset \geq 7/16"-20$	-	ALL SIZES
	G	$\emptyset \geq 1/4"-19$	$\emptyset \geq 1/4"-19$	$\emptyset \geq 1/4"-19$	-	ALL SIZES

Formulae

Parameter	Formula	Unit of Measurement
Cutting speed	$V_c = \frac{N \cdot \pi \cdot d_1}{1000}$	$\frac{\text{m}}{\text{min}}$
Rotational speed	$N = \frac{1000 \cdot V_c}{\pi \cdot d_1}$	rpm
Torque(*)	$M_t = \frac{K_c \cdot p^2 \cdot z^{0.6} \cdot d_1}{10^4}$	N · m
Spindle power	$P = \frac{M_t \cdot 2 \cdot \pi \cdot N}{60}$	W
Nominal diameter	d_1	mm
Feed	$p \cdot N$	$\frac{\text{mm}}{\text{min}}$
p	Thread pitch	mm
z	Number of flutes	-
K_c	Cutting force coefficient (function of the material and of tap wear)	$\frac{\text{N}}{\text{mm}^2}$

M.G.	K_c [N/mm ²]
P.1	1300
P.2	1400
P.3	1400
P.4	1600
P.5	1700
P.6	2000
P.7	1400
M.1	1600
M.2	1800
K.1	1100
K.2	1500
K.3	1600
N.1	600
N.2	800
N.3	900
N.4	1000
N.5	700
N.6	850
N.7	900
N.8	2500
N.9	400
N.10	500
S.1	1200
S.2	1900
S.3	1300
S.4	2400

(*) The torque value is valid for a new cutting tap.







For worn-out taps, the value can increase up to 2-3 times. For forming taps, the value must be multiplied by 1,5-2 times.

Conversion table hardness vs tensile strength

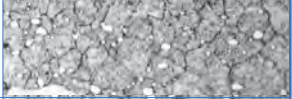
Tensile Strength	Hardness		
	R [N/mm ²]	HB Brinell	HRC Rockwell C
3400	700	68	1008
3120	688	67	955
2960	676	66	920
2890	670	65	885
2770	659	64	850
2240	650	63	826
2190	635	62	797
2140	627	61	772
2100	613	60	746
2050	600	59	720
2010	587	58	693
1970	574	57	666
1930	561	56	646
1890	548	55	623
1850	536	54	604
1810	524	53	585
1780	512	52	567
1730	500	51	549
1680	488	50	528
1630	476	49	513
1590	464	48	497
1560	453	47	482
1520	442	46	468
1480	430	45	453
1440	419	44	440

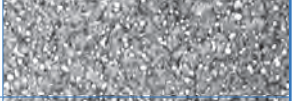
Tensile Strength	Hardness		
	R [N/mm ²]	HB Brinell	HRC Rockwell C
1400	408	43	427
1360	398	42	416
1320	389	41	404
1300	377	40	391
1260	367	39	381
1230	357	38	371
1190	347	37	357
1150	337	36	345
1120	327	35	332
1100	319	34	323
1060	309	33	314
1040	301	32	304
1010	294	31	296
980	286	30	288
960	279	29	280
940	272	28	273
910	265	27	266
890	259	26	259
870	253	25	253
850	247	24	247
830	241	23	241
810	235	22	235
790	230	21	230
770	225	20	225

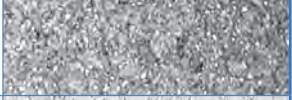
High speed steel and solid carbide for taps

Vergnano Designation	Designation according to ISO 11054	Hardness	Toughness	Applications	Structure (500x)
HSS	HSS	•	•	Used exclusively for hand taps (except A100).	
HSSE	HSS-E	•	• •	For general applications.	
HSSK	HSS-E-PM	• •	• • •	Used in applications where a compromise between high hardness and high toughness is needed.	
HSSZ	HSS-E-PM	• •	• • •	For applications where extremely high performance and productivity are requested.	
HSSP	HSS-E-PM	• • •	• •	For tough materials and extreme applications.	
HM	-	• • •	-	For heat-treated steels and abrasive materials.	

Coatings and surface treatments - properties

Type of coating / treatment	Structure	Hardness	Friction Coefficient	Oxidation Temperature	Features
TiN	Mono-layer	• •	• •	•	Wear resistance
TiCN	Mono-layer	• •	• •	•	Wear resistance
TiX2	Multi-layer	• • •	• • •	• •	Oxidation and wear resistance, chip evacuation
TiH1	Multi-layer	• • •	• • •	• •	Oxidation and wear resistance, chip evacuation
G-MAXX	Multi-layer	• • •	• • •	• •	Oxidation and wear resistance, chip evacuation
CrN	Mono-layer	•	• •	• •	Wear resistance, chip evacuation
V-MAXX	Mono-layer	• • •	• •	• • •	Wear resistance, chip evacuation
RED-MAXX	Mono-layer	• • •	• •	• • •	Wear resistance, chip evacuation
VAP	Surface oxidation	-	• •	•	Chip evacuation
NiTR	Surface hardening	•	•	•	Wear resistance

Excellent • • • •
 Very good • • •
 Good •

Coatings - applications for cuttings taps

COATINGS RECOMMENDED FOR CUTTINGS TAPS				TiN	TiCN	TiX2	TiH1	CrN	V-MAXX	G-MAXX	VAP	NiTR
ISO	Material	Group	Application	Coating								
P	Steel	P.1	Mild / magnetic steel	○			○				●	
		P.2	Construction steel, case hardening steel	●			○				○	
		P.3	Carbon steel	●			○					
		P.4	Alloyed steel / tempered steel	○	○		●					
		P.5	Alloyed steel / tempered steel	○	○		●					
		P.6	Alloyed steel / high strength steel	○	○		●					
		P.7	Ferritic stainless steel, martensitic stainless steel, precipitation hardening	○		●					●	○
M	Stainless Steel	M.1	Austenitic stainless steel			●	○			●	○	
		M.2	Ferritic+austenitic (Duplex)			●	○			●	○	
K	Cast iron	K.1	Grey cast iron		○				●			○
		K.2	Nodular cast iron, malleable cast iron, tempered cast iron	●			○					
		K.3	Austempered ductile iron (ADI)						●			
N	Aluminium Aluminium alloys	N.1	Pure aluminium				●				○	
		N.2	Aluminium wrought and die cast alloys with Si < 0,5% (long chipping)	○			●				○	
		N.3	Aluminium wrought and die cast alloys with Si > 10% (medium chipping)	○			●				○	
		N.4	Aluminium die cast alloys with Si > 10% (short chipping)		○				●			○
	Copper Copper alloys Brass Bronze	N.5	Pure copper				●				○	
		N.6	Copper alloys (long chipping), soft brass	○			●				○	
		N.7	Copper alloys (short chipping), hard brass		●							○
	Magnesium Magnesium alloys	N.8	High strength bronze		○				●			○
		N.9	Pure magnesium, magnesium alloys		○							●
		N.10	High strength magnesium alloys		○							●
S	Titanium Titanium alloys	S.1	Pure titanium				○	●				
		S.2	Titanium alloys				○	●				
	Nickel Nickel alloys	S.3	Pure nickel	○			●					
		S.4	Nickel alloys	○			●					
H	Hardened materials	H.1	Alloyed steel, hardness HRC 44-55						○			
		H.2	Alloyed steel, hardness HRC 56-63						○			

Coatings - applications for cold forming taps

COATINGS RECOMMENDED FOR COLD FORMING TAPS				TiN	V-MAXX	RED-MAXX
ISO	Material	Group	Application	Coating		
P	Steel	P.1	Mild / magnetic steel	○		
		P.2	Construction steel, case hardening steel	●	●	
		P.3	Carbon steel	●	●	●
		P.4	Alloyed steel / tempered steel	●	●	●
		P.5	Alloyed steel / tempered steel	●	●	●
		P.7	Ferritic stainless steel, martensitic stainless steel, precipitation hardening	○	●	○
M	Stainless Steel	M.1	Austenitic stainless steel	○	●	○
		M.2	Ferritic+austenitic (Duplex)	○	●	○
N	Aluminium Aluminium alloys	N.1	Pure aluminium	○		
		N.2	Aluminium wrought and die cast alloys with Si < 0,5% (long chipping)	●	●	○
		N.3	Aluminium wrought and die cast alloys with Si < 10 % (medium chipping)	●	●	○
	Copper Copper alloys Brass/Bronze	N.5	Pure copper	○	●	○
N.6		Copper alloys (long chipping), soft brass	●	●		
S	Titanium Titanium alloys	S.1	Pure titanium		●	●
		S.2	Titanium alloys		●	●
	Nickel Nickel alloys	S.3	Pure nickel	○	●	●
		S.4	Nickel alloys	○	●	●

- Ideal
- Suitable

Troubleshooting

Tapping is a complex process and often the last machining operation performed on the workpiece.

Therefore, incorrect or faulty tapping can compromise the quality of the entire workpiece.

Numerous factors influence the process: cutting parameters, drilling parameters, lubrication, machine conditions.

The choice of the correct tool is paramount in order to obtain high quality threads.

The following table summarises the most common problems encountered during tapping and their possible solutions.

Problem	Solution
Chipped teeth on tap	<ul style="list-style-type: none"> • Choose correct tap, with lower rake angle or longer chamfer. • Reduce cutting speed. • Check drilled hole size is not too small. • Check tap alignment and run-out of tap on tapping attachment. • For deep blind holes ($\geq 2,5xD$) use taps with back-tapering.
Excessive tap wear	<ul style="list-style-type: none"> • Improve quality (richer emulsion, neat oil) and quantity (higher pressure) of lubrication. • Use correct tap, with more relief or longer chamfer if possible. • Choose coating suitable for specific application. • Use recommended cutting parameters for specific application.
Chips clogging flutes	<ul style="list-style-type: none"> • Use tap with lower spiral flute angle. • Choose correct tap with suitable rake angle and relief for specific application. • Use tap with sharp cutting edge (bright tap or vapourised tap).
Poor finish on threaded workpiece	<ul style="list-style-type: none"> • Check wear on tap. If necessary, sharpen or change tap. • Improve quality and quantity of lubrication. • Choose correct tap with suitable rake angle and relief for specific application. • Use recommended cutting parameters for specific application.
Built-up-edge	<ul style="list-style-type: none"> • Choose correct tap with lower rake angle and/or higher relief. • Choose coating suitable for specific application. • Increase cutting speed. • Improve quality and quantity of lubrication.



Troubleshooting

Problem	Solution
Tap sticking	<ul style="list-style-type: none">• Choose correct tap with lower rake angle and/or higher relief.• Choose coating suitable for specific application.• Increase cutting speed.• Improve quality and quantity of lubrication.
Crater wear	<ul style="list-style-type: none">• Choose suitable tap, with base material in HSSE-PM.• Use coated tap.• Improve quality and quantity of lubrication.
Tap breakage	<ul style="list-style-type: none">• Check drilled hole size.• Check alignment between tap and drilled hole.• Reduce cutting speed.• On blind holes, check that tapping depth is less than hole depth.• Use tapping attachment with slip clutch.• Use compensated tapping attachment.
Oversized thread	<ul style="list-style-type: none">• Check tap tolerance is compatible with requested workpiece (nut) tolerance.• Choose correct tap with suitable rake angle and relief for specific application.• Reduce feed rate (revs x pitch) or use rigid / synchronous tapping attachment.• Reduce cutting speed.• Check tap alignment and that workpiece is fastened steadily.• Remove clogged chips from flutes.
Undersized thread	<ul style="list-style-type: none">• Check drilled hole size is not too small.• Check tap tolerance is compatible with requested workpiece (nut) tolerance.• Use coated tap to avoid tap sticking.• On forming taps, use slightly larger drilled hole size.• Check wear on tap. If necessary, sharpen or change tap.• Choose correct tap with higher rake angle and relief.• Use rigid / synchronous tapping attachment.• Improve quality and quantity of lubrication.
Excessive power requirement	<ul style="list-style-type: none">• On high strength materials, increase drilled hole size.• Check wear on tap. If necessary, sharpen or change tap.• Choose correct tap with higher rake angle and relief.• Improve quality and quantity of lubrication.

Material examples

			Germany	Italy	France	United States
ISO 513	Application	W.Nr.	DIN	UNI	AFNOR	AISI/SAE/ASTM
P STEEL	Mild/magnetic	1.1015	RFe60			
		1.1014	RFe80			
		1.1013	RFe100			
	Structural	1.0037	St 37-2	Fe360B	E 24-2	1013
		1.0044	St 44-2	Fe430B	E 28-2	1021
		1.0050	St 50-2	Fe490	A 50-2	A 570 (50)
		1.0060	St 60-2	Fe590	A 60-2	A 572 (65)
		1.0570	St 52-3	Fe510B	E 36-3	1024
	Case hardening	1.0301	C10	C10	C10	1010
		1.0401	C15	C15	C18	1015
		1.7131	16MnCr5	16MnCr5	16 MC 5	5115
		1.7147	20MnCr5	20MnCr5	20 MC 5	5120
		1.7243	18CrMo4	18CrMo4		
		1.5919	15CrNi6	16CrNi4	16 NC 6	4320
		1.6523	21NiCrMo2	20NiCrMo2	20 NCD 2	8620
		1.6587	17CrNiMo1106	18NiCrMo5-7	18 NCD6/18 NCD7	4320
	Nitriding	1.8515	31CrMo12	31CrMo12	30 CD 12	A/B
		1.8519	31CrMoV9	31CrMoV10		
		1.8507	34CrAlMo5	34CrAlMo7	30 CAD 6.12	A355Cl.D
		1.8509	41CrAlMo7	41CrAlMo7	40 CAD 6.12	E7140
	Free cutting	1.0711	9S20	9S20		1212
		1.0715	9SMn28	9SMn28	S 250	1213
		1.0718	9SMnPb28	9SMnPb28	S 250 Pb	12 L 13
		1.0726	35S20	35S20	35 MF 4	1140
		1.0736	9SMn36	9SMn36	S 300	1215
		1.0737	9SMnPb36	9SMnPb36	S 300 Pb	12 L 14
	Heat-treatable	1.0406	C25	C25	AF 50 C 30	1025
		1.0528	C30	C30		1030
		1.0501	C35	C35	AF 55 C 35	1035
		1.0511	C40	C40	AF 60 C 40	1040
		1.0503	C45	C45	AF 65 C 45	1045
		1.0540	C50	C50		1050
		1.0535	C55	C55	C54	1055
		1.0601	C60	C60	C60	1060
		1.7035	41Cr4	41Cr4	41Cr4	5140
		1.8159	51CrV4	51CrV4	50 CV 4	6150
		1.7218	25CrMo4	25CrMo4	25 CD 4	4130
		1.7220	34CrMo4	34CrMo4	35 CD 4	4137
		1.7225	42CrMo4	42CrMo4	42 CD 4	4140
		1.7228	50CrMo4	50CrMo4	50CrMo4	4150
		1.6580	30CrNiMo8	30CrNiMo8	30 NCD 8	
	1.6582	34CrNiMo6	34CrNiMo6	35 NCD 6	4337	
	1.6511	36CrNiMo4	36CrNiMo4	40 NCD 3	9840	
	1.6773	36NiCrMo16	36NiCrMo16			
	Ball bearing	1.3505	100Cr6	100Cr6	100C6	52100
		1.3536	100CrMo7-3	100CrMo7		
	Spring	1.1231	Ck67	C67	XC 68	1070
		1.1248	Ck75	C75		1074
		1.1269	Ck85	C85	C90	1086
		1.1274	Ck101	C100	C100	1095
		1.5021		48Si7		
		1.5026	55Si7	55Si7	56SC7	9255
		1.5027		60Si7	60Si7	9260
		1.7108	60SiCr7	60SiCr8		9262
		1.8159	51CrV4	51CrV4	50 CV 4	6150
		1.7176	55Cr3	55Cr3	55 C 3	5155
	1.7701	51CrMoV4	51CrMoV4			
	Superficial hardening	1.1183	Cf 35	C36	XC 68 HITS	
		1.1193	Cf 45	C43	XC 42 HITS	
		1.1213	Cf 53	C53	XC 48 HITS	1050
		1.7005	45Cr2	45Cr2		
		1.7043	38Cr4	38Cr4		
		1.7034	37Cr4	36CrMn4	38 C 4	5135
	1.7223	41CrMo4	41CrMo4	42 CD 4 TS	4142	

Russia	Japan	China	India			
GOST	JIS	GB	IS	MG Vergnano	Application	ISO 513
20860				P.1	Mild/magnetic	P STEEL
20880				P.1		
20895				P.1		
St3kp/St3ps	STKM12C	Q235A		P.2	Structural	
St4ps/St4sp	STK400	Q275B	Fe440	P.2		
St5ps/St5sp	SS490	Q275	Fe490	P.2		
St6ps/St6sp	S45C	45	Fe570	P.2		
17G1S	STK490	16Mn	Fe540	P.2		
10	S10C	10		P.2	Case hardening	
15	S15C	15	14C6	P.2		
18ChG	SCR415	20CrMn	16Mn5Cr4	P.2		
18 ChG	SMnC420H	20CrMn	20Mn5Cr5	P.2		
				P.2		
15ChGN2T	SNCM415M		15Cr6Ni6	P.2		
20ChGNM	SNCM220M	20CrNiMo		P.2		
20ChN2M			16Ni6Cr7Mo3	P.2		
	SBV1A/SBV1B			P.4	Nitriding	
				P.5		
				P.4		
38Ch2MJuA	SACM645	38CrMoAl	40Cr7Al10Mo2	P.5	Free cutting	
A11	SUM21	Y12		P.1		
	SUM22	Y15		P.1		
	SUM22L	Y15Pb		P.1		
A35		Y35		P.2		
	SUM25			P.1	Heat-treatable	
	SUM24L			P.1		
25	S25C	25	25C4	P.3		
30	S30C	30	30C8	P.3		
35	S35C	35	35C8	P.3		
40	S40C	40	40C8	P.3		
45	S45C	45	45C8	P.3		
50	S50C	50	50C8	P.3		
55	S55C	55	55C8	P.3		
60	S58C	60	C604	P.3		
40Ch	SCR440(H)	40Cr	40Cr4	P.4 (norm.) / P.5 (bonif.)		
50Ch	SUP10	50CrVA	50Cr4V2	P.4 (norm.) / P.5 (bonif.)		
30ChM	SCCrM1	30CrMo	21Cr4Mo2	P.4 (norm.) / P.5 (bonif.)		
35ChML	SCM435	35CrMo		P.4 (norm.) / P.5 (bonif.)		
38ChA	SCM440	42CrMo	40CrMoH	P.4 (norm.) / P.5 (bonif.)		
50Ch	SCM445(H)	ZG50Cr1Mo		P.4 (norm.) / P.5 (bonif.)		
	SNCM431			P.5 (norm.) / P.6 (bonif.)		
38Ch2N2MA	SNCM439			P.5 (norm.) / P.6 (bonif.)		
40ChGMN		40CrNiMoA		P.4 (norm.) / P.5 (bonif.)		
				P.5 (norm.) / P.6 (bonif.)	Ball bearing	
SChCh15	SUJ2/SUJ4	GCr15		P.4 (norm.)		
				P.4 (norm.)		
65	S70C-CSP	65	70C6	P.3	Spring	
75A	S75CM	75		P.3		
85A	SK85	85		P.3		
	SK4-CSP	T10A	98C6	P.3		
				P.4 (norm.) / P.5 (bonif.)		
55S2/55S2A		55Si2Mn	55Si7	P.4 (norm.) / P.5 (bonif.)		
60S2	SUP6	60Si2Mn	60Si7	P.4 (norm.) / P.5 (bonif.)		
60S2G		60Si2CrA		P.4 (norm.) / P.5 (bonif.)		
50Ch	SUP10	50CrVA	50Cr4V2	P.4 (norm.) / P.6 (bonif.)		
50ChGA	SUP9(A)	55CrMnA	55Cr3	P.4 (norm.) / P.6 (bonif.)		
				P.4 (norm.) / P.6 (bonif.)		
				P.3		Superficial hardening
				P.3		
50	S50C			P.3		
				P.4		
		38CrA		P.5		
35Ch	SCR435H	35Cr		P.5		
40ChFA	SNB22	42CrMo	40Cr4Mo3	P.5		

Material examples

			Germany	Italy	France	United States	
ISO 513	Application	W.Nr.	DIN	UNI	AFNOR	AISI/SAE/ASTM	
P STEEL	Hot-work	1.2767	45NiCrMo16	40NiCrMoV16 KU	Y35NCD16		
		1.2713	55NiCrMoV7	55NiCrMoV7 KU	55NiCrMoV7	L6	
		1.2311		35CrMo8 KU			
		1.2365	32CrMoV12-28	30CrMoV12-27 KU	32CDV12-28	H10	
		1.2343	X38CrMoV5-1	X37CrMoV5-1 KU	Z38CDV5	H11	
		1.2344	X40CrMoV5-1	X40CrMoV5-1-1 KU	Z40CDV5	H13	
		1.2567	X30WCrV5-3	X30WCrV5-3 KU	Z32WCV5	H14	
	Ferritic stainless steel	1.2581	X30WCrV9-3	X30WCrV9-3 KU	Z30WCV9	H21	
		1.4002	X6CrAl13	X6CrAl13	Z 8 CA 12	405	
		1.4512	X2CrTi12	X6CrTi12	Z 3 CT 12	409	
		1.4016	X6Cr17	X8Cr17	Z 8 C 17	430	
	Martensitic stainless steel	1.4104	X14CrMoS17	X10CrS17	Z 13 CF 17	430F	
		1.4006	X12Cr13	X12Cr13	Z 10 C 13	410	
		1.4005	X12CrS13	X12CrS13	Z 11 CF 13	416	
		1.4021	X20Cr13	X20Cr13	Z 20 C 13	420	
		1.4028	X30Cr13	X30Cr13	Z 30 C 13	420	
		1.4057	X17CrNi16-2	X16CrNi16	Z 15 CN 16-02	431	
	Precipitation hardening	1.4125	X105CrMo17		Z 100 CD 17	440C	
		1.4542	X5CrNiCuNb16-4		Z 7 CNU 15-05	630	
	M STAINLESS STEEL	Austenitic	1.4319	X3CrNiN17-8	X10CrNi1809		302
1.4305			X8CrNiS18-9	X10CrNiS1809	Z 8 CNF 18-09	303	
1.4301			X5CrNi18-10	X5CrNi1810	Z 4 CN 19-10 FF	304	
1.4306			X2CrNi19-11	X2CrNi1811	Z 1 CN 18-12	304L	
1.4303			X4CrNi18-12	X8CrNi1812	Z 5 CN 18-11 FF	305	
1.4828			X15CrNiSi20-12	X16CrNi2314	Z 9 CN 24-13	309	
1.4841			X15CrNiSi25-20	X22CrNiSi2520	Z 15 CNS 25-20	310	
1.4401			X5CrNiMo17-12-2	X5CrNiMo1712	Z 3 CND 17-11-01	316	
1.4404			X2CrNiMo17-12-2	X2CrNiMo1712	Z 2 CND 17-12	316L	
1.4541			X6CrNiTi18-10	X6CrNiTi1811	Z 6 CNT 18-10	321	
Duplex		1.4550	X6CrNiNb18-10	X6CrNiNb1811	Z 6 CNNb 18-10	347	
		1.4462	X2CrNiMoN22-5-3	X2CrNiMoN22-5-3	Z 3 CND 22-05 Az	S31803	
		1.4501	X2CrNiMoCuWN25-7-4	X2CrNiMoCuWN25-7-4		S32760	
K CAST IRON	Grey cast iron	0.6010	GG10	G10	Ft10D	A48-20B	
		0.6015	GG15	G15	Ft15D	A48-25B	
		0.6020	GG20	G20	Ft20D	A48-30B	
		0.6025	GG25	G25	Ft25D	A48-40B	
		0.6030	GG30	G30	Ft30D	A48-45B	
		0.6035	GG35	G35	Ft35D	A48-50B	
		0.6040	GG40	G40	Ft40D	A48-60B	
	Nodular cast iron / tempered	0.7040	GGG40	GS400-12	FGS400-12	60-40-18	
		0.7050	GGG50	GS500-7	FGS500-7	65-45-12	
		0.7060	GGG60	GS600-3	FGS600-3	80-55-06	
		0.7070	GGG70	GS700-2	FGS700-2	100-70-03	
	Malleable cast iron	0.8035	GTW35-04				
		0.8055	GTW55				
	Austempered ductile iron		EN-GJS-800-8				
			EN-GJS-1000-5				
			EN-GJS-1200-2				
		EN-GJS-1400-1					
N NON-FERROUS METALS	Pure aluminium	3.0205	Al99	9001/1	1200 (A4)	1200	
		3.0305	Al99.9				
	Al wrought alloys	3.0505	AlMn0.5Mg0.5			3105	
		3.0915	AlFeSi	8011		8011	
		3.3315	AlMg1	9005/1		5005 (AlMg1)	5005
		3.3525	AlMg2Mn0.3			5251	5251
		3.3527	AlMg2Mn0.8			5049	5049
		3.3545	AlMg4Mn	9005/4		5086 (AG4MC)	5086
		3.3555	AlMg5				
		3.0615	AlMgSiPb			6012	

Russia	Japan	China	India			
GOST	JIS	GB	IS	MG Vergnano	Application	ISO 513
5ChNM	SKT4	5CrNiMo	T55Ni7Cr3Mo3V1	P.5 (ricott.) P.4 (ricott.) P.4 (ricott.)	Hot-work	P STEEL
3Ch3M3F	SKD7	4Cr3Mo3SiV		P.4 (ricott.)		
4Ch5MFS	SKD6	4Cr5MoSiV	XT35Cr5Mo1V3	P.4 (ricott.)		
4Ch5MF1S	SKD61	4Cr5MoSiV1	XT35Cr5Mo1V1	P.4 (ricott.)		
4Ch2W5MF	SKD4	30W4Cr2VA		P.4 (ricott.)		
3Ch3W8F	SKD5	3Cr2W8V	XT33W9Cr3V4	P.4 (ricott.)		
	SUS405	0Cr13Al	X04Cr13	P.7		
	SUS409TB	022Cr11NbTi		P.7	Ferritic stainless steel	
	SUS430	1Cr17	X07Cr17	P.7		
	SUS430F	Y1Cr17		P.7		
	SUS410	1Cr13	X12Cr12	P.7	Martensitic stainless steel	
	SUS416	Y1Cr13		P.7		
20Ch13	SUS420J1	2Cr13	X20Cr13	P.7		
30Ch13	SUS420J2	3Cr13	X30Cr13	P.7		
14Ch17N2	SUS431	1Cr17Ni2	X15Cr16Ni2	P.7		
95Ch18	SUS440C	108Cr17	X108Cr17Mo	P.7		
	SUS630/SCS24	0Cr17Ni4Cu4Nb		M.2	Precipitation hardening	
	SUS302			M.1	Austenitic	M STAINLESS STEEL
	SUS303			M.1		
08Ch18N10	SUS304	0Cr18Ni9	X04Cr18Ni10	M.1		
03Ch18N11	SUS304L/SCS19	00Cr19Ni10	X02Cr19Ni10	M.1		
12Ch18N12T	SUS305J1	1Cr18Ni12		M.1		
	SUH309	1Cr20Ni14Si2	X15Cr24Ni13	M.1		
20Ch25N20S2	SUH310	1Cr25Ni20Si2	X20Cr25Ni20	M.1		
08Ch16N11M3	SUS316	0Cr17Ni12Mo2	X04Cr17Ni12Mo2	M.1		
	SUS316L	00Cr17Ni14Mo2	X02Cr17Ni12Mo2	M.1		
08Ch18N10T	SUS321	0Cr18Ni10Ti	X04Cr18Ni10Ti	M.1		
08Ch18N12B	SUS347	0Cr18Ni11Nb	X04Cr18Ni10Nb	M.1		
	SUS329J3L	022Cr22Ni5Mo3N		M.2	Duplex	
		022Cr25Ni7Mo3WCuN		M.2		
Sc10	FC10			K.1	Grey cast iron	K CAST IRON
Sc15	FC15	HT150	FG150	K.1		
Sc20	FC20	HT200	FG200	K.1		
Sc25	FC25	HT250	FG260	K.1		
Sc30	FC30	HT300	FG300	K.1		
Sc35	FC35			K.1		
Sc40				K.1		
VC 42-12	FCD40	QT400-15		K.2	Nodular cast iron / tempered	
VC 50-2	FCD50	QT500-7	SG500/7	K.2		
VC 60-2	FCD60	QT600-3	SG600/3	K.2		
VC 70-2	FCD70	QT700-2	SG700/2	K.2		
				K.2	Malleable cast iron	
				K.2		
				K.3	Austempered ductile iron	
				K.3		
				K.3		
				K.3		
	A1200			N.1	Pure aluminium	N NON-FERROUS METALS
				N.1		
	A3105			N.2	Al wrought alloys	
				N.2		
	A5005			N.2		
				N.2		
	A5086			N.2		
	A5056			N.2		
				N.2		

Material examples

ISO 513	Application	W.Nr.	Germany DIN	Italy UNI	France AFNOR	United States AISI/SAE/ASTM	
N NON-FERROUS METALS	Al wrought alloys	3.1255	AlCuSiMn	9002/3	2014	2014	
		3.1325	AlCuMg1	9002/2	2017 A (AU4G)	2017A	
		3.1355	AlCuMg2	9002/4	2024 (AU4G1)	2024	
		3.1645	AlCuMgPb	9002/8	2030 (AU4PB)	2030	
		3.4335	AlZn4.5Mg1	9007/1	7020 (AZ5G)	7020	
	Al casting alloys	3.1371	G-AlCu4TiMg				
		3.2134	G-AlSi5Cu1Mg				
		3.3241	G-AlMg3Si				
		3.3261	G-AlMg5Si				
		3.3541	G-AlMg3				
		3.2373	G-AlSi9Mg				
		3.2381	G-AlSi10Mg				
		3.2383	G-AlSi10Mg(Cu)				
	Pure copper	2.0060	E-Cu57				C11000
		2.0065	E-Cu58		5649	CuA1	C11000
	Cu wrought alloys	2.1525	CuSi3Mn		CuSi3Mn1		C65500
		2.0855	CuNi2Si		CuNi2Si		C64700
		2.1247	CuBe2		Classe IV		C17200
		2.1285	CuCo2Be		Classe III		C17510
	Brass	2.0240	CuZn15				
		2.0250	CuZn20				
		2.0265	CuZn30				C26000
		2.0280	CuZn33				
		2.0321	CuZn37				C27450
		2.0360	CuZn40				C28000
		2.0410	CuZn44Pb2		CuZn43Pb2Al		C38000
	2.0550	CuZn40Al2		CuZn37Mn3Al2PbSi		C67410	
	Bronze	2.1016	CuSn4				
		2.1020	CuSn6				
		2.1030	CuSn8				
		2.1086	G-CuSn10Zn		7013	U-E12P7U-E8Z2	C90500
		2.0978	CuAl11Ni6Fe6		CuAl11Fe6Ni6		
		2.0940	CuAl10Fe		5274		C95400
2.0882		CuNi30Mn1Fe					
3.5312		MgAl3Zn					
3.5632		MgAl6Zn3					
3.5912	MgAl9Zn1						
3.5161	MgZn6Zr						
S SUPERALLOYS AND TITANIUM	Pure titanium	3.7024	Ti99.5				
		3.7034	Ti99.7				
	Titanium alloys	3.7165	TiAl6V4			T-A6V	
		3.7174	TiAl6V4Sn2				
	Pure Nickel	1.3911	RNi24				
		1.3926	RNi12				
	Nickel alloys	2.4858	NiCr21Mo (Incoloy 825)				
2.4668		NiCr19Fe19NbMo (Inconel 718)			INCONEL 718		
2.4630		Ni-Cr20Ti (Nimonic 75)			NIMONIC 75		
2.4665		NiCr22Fe18Mo (Hastelloy X)					
H HARDENED MATERIALS	Ball bearing	1.3505	100Cr6	100Cr6	100C6	52100	
		1.3536	100CrMo6	100CrMo7	100CD7	3	
	Hot-work	1.2767	45NiCrMo16	40NiCrMoV16 KU		Y35NCD16	
		1.2713	55NiCrMoV7	55NiCrMoV7 KU		55NiCrMoV7	L6
		1.2311		35CrMo8 KU			
		1.2365	32CrMoV12-28	30CrMoV12-27 KU		32CDV12-28	H10
		1.2343	X38CrMoV5-1	X37CrMoV5-1 KU		Z38CDV5	H11
		1.2344	X40CrMoV5-1	X40CrMoV5-1-1 KU		Z40CDV5	H13
		1.2567	X30WCrV5-3	X30WCrV5-3 KU		Z32WCV5	H14
		1.2581	X30WCrV9-3	X30WCrV9-3 KU		Z30WCV9	H21

Russia	Japan	China	India			
GOST	JIS	GB	IS	MG Vergnano	Application	ISO 513
	A2014			N.2	Al wrought alloys	N NON-FERROUS METALS
	A2017			N.2		
	A2024			N.2		
	A7N01			N.2	Al casting alloys	
	AC1B			N.2		
	AC4D			N.3		
				N.2		
				N.2		
				N.2		
	AC4A			N.3	Pure copper	
	ADC3			N.4		
	AC3A			N.4		
	ADC1			N.4	Cu wrought alloys	
	C1100			N.5		
	C1100			N.5		
				N.6	Brass	
				N.6		
				N.6		
				N.6	Bronze	
	C2600			N.6		
				N.6		
	C2700			N.6		
	C2800			N.7		
				N.7		
				N.7	Titanium alloys	
				N.6		
				N.6		
				N.6		
	CAC403C (BC3)			N.7		
				N.8		
	CAC702C			N.8	Pure titanium	
				N.8		
				N.9		
				N.9		
				N.9	Titanium alloys	
				N.10		
				S.1		
				S.1		
				S.2	Pure Nickel	
				S.2		
				S.3	Nickel alloys	
				S.3		
	NCF825			S.4		
				S.4		
				S.4	Ball bearing	
				S.4		
SChCh15	SUJ2/SUJ4	GCr15		H.2 (bonif.)	H HARDENED MATERIALS	
				H.2 (bonif.)		
	SKT6			H.1 (bonif.)		
5ChNM	SKT4	5CrNiMo	T55Ni7Cr3Mo3V1	H.1 (bonif.)		
				H.1 (bonif.)		
3Ch3M3F	SKD7	4Cr3Mo3SiV		H.1 (bonif.)		
4Ch5MFS	SKD6	4Cr5MoSiV	XT35Cr5Mo1V3	H.1 (bonif.)		
4Ch5MF1S	SKD61	4Cr5MoSiV1	XT35Cr5Mo1V1	H.1 (bonif.)		
4Ch2W5MF	SKD4	30W4Cr2VA		H.1 (bonif.)		
3Ch3W8F	SKD5	3Cr2W8V	XT33W9Cr3V4	H.1 (bonif.)		

Drill size cutting taps

ISO Metric coarse thread DIN 13			
D	Pitch [mm]	Maximum core diam. (tol. 6H)[mm]D1	Drill size* [mm]
M 1	0,25	0,785 ⁽¹⁾	0,75
1,1	0,25	0,885 ⁽¹⁾	0,85
1,2	0,25	0,985 ⁽¹⁾	0,95
1,4	0,3	1,142 ⁽¹⁾	1,1
1,6	0,35	1,321	1,25
1,7 ⁽³⁾	0,35	1,421	1,35
1,8	0,35	1,521	1,45
2	0,4	1,679	1,6
2,2	0,45	1,838	1,75
2,3 ⁽³⁾	0,4	1,938	1,9
2,5	0,45	2,138	2,05
2,6 ⁽³⁾	0,45	2,238	2,1
3	0,5	2,599	2,5
3,5	0,6	3,010	2,9
4	0,7	3,422	3,3
4,5	0,75	3,878	3,7
5	0,8	4,334	4,2
6	1	5,153	5
7	1	6,153	6
8	1,25	6,912	6,8
9	1,25	7,912	7,8
10	1,5	8,676	8,5
11	1,5	9,676	9,5
12	1,75	10,441	10,2
14	2	12,210	12
16	2	14,210	14
18	2,5	15,744	15,5
20	2,5	17,744	17,5
22	2,5	19,744	19,5
24	3	21,252	21
27	3	24,252	24
30	3,5	26,771	26,5
33	3,5	29,771	29,5
36	4	32,270	32
39	4	35,270	35
42	4,5	37,799	37,5
45	4,5	40,799	40,5
48	5	43,297	43
52	5	47,297	47
56	5,5	50,796	50,5
60 ⁽³⁾	5,5	54,796	54,5
64 ⁽³⁾	6	58,305	58
68 ⁽³⁾	6	62,305	62

ISO Metric fine thread DIN 13							
D	Pitch [mm]	Maximum core diam. (tol. 6H)[mm]D1	Drill size* [mm]	D	Pitch [mm]	Maximum core diam. (tol. 6H)[mm]D1	Drill size* [mm]
M 2 ⁽³⁾	0,25	1,774 ⁽²⁾	1,75	M 25	1	24,153	24
2,3 ⁽³⁾	0,25	2,085	2,05	25	1,5	23,676	23,5
2,5	0,35	2,221	2,15	25	2	23,210	23
3	0,35	2,721	2,65	26	1,5	24,676	24,5
3,5	0,35	3,221	3,15	27	1	26,153	26
4	0,5	3,599	3,5	27	1,5	25,676	25,5
4,5	0,5	4,099	4	27	2	25,210	25
5	0,5	4,599	4,5	28	1	27,153	27
5,5	0,5	5,099	5	28	1,5	26,676	26,5
6	0,75	5,378	5,2	28	2	26,210	26
7	0,75	6,378	6,2	30	1	29,153	29
8	0,75	7,378	7,2	30	1,5	28,676	28,5
8	1	7,153	7	30	2	28,210	28
9	0,75	8,378	8,2	30	3	27,252	27
9	1	8,153	8	32	1,5	30,676	30,5
10	0,75	9,378	9,2	32	2	30,210	30
10	1	9,153	9	33	1,5	31,676	31,5
10	1,25	8,912	8,8	33	2	31,210	31
11	0,75	10,378	10,2	33	3	30,252	30
11	1	10,153	10	35	1,5	33,676	33,5
12 ⁽³⁾	0,75	11,378	11,2	36	1,5	34,676	34,5
12	1	11,153	11	36	2	34,210	34
12	1,25	10,912	10,8	36	3	33,252	33
12	1,5	10,676	10,5	38	1,5	36,676	36,5
14	1	13,153	13	39	1,5	37,676	37,5
14	1,25	12,912	12,8	39	2	37,210	37
14	1,5	12,676	12,5	39	3	36,252	36
15	1	14,153	14	40	1,5	38,676	38,5
15	1,5	13,676	13,5	40	2	38,210	38
16	1	15,153	15	40	3	37,252	37
16	1,5	14,676	14,5	42	1,5	40,676	40,5
17	1	16,153	16	42	2	40,210	40
17	1,5	15,676	15,5	42	3	39,252	39
18	1	17,153	17	45	1,5	43,676	43,5
18	1,5	16,676	16,5	45	2	43,210	43
18	2	16,210	16	45	3	42,252	42
20	1	19,153	19	48	1,5	46,676	46,5
20	1,5	18,676	18,5	48	2	46,210	46
20	2	18,210	18	48	3	45,252	45
22	1	21,153	21	50	1,5	48,676	48,5
22	1,5	20,676	20,5	50	2	48,210	48
22	2	20,210	20	50	3	47,252	47
24	1	23,153	23	52	1,5	50,676	50,5
24	1,5	22,676	22,5	52	2	50,210	50
24	2	22,210	22	52	3	49,252	49

(*) Drill size according to DIN 336

(¹) Tolerance 5H

(²) Tolerance 4H

(³) Size not included in DIN 336

Drill size cutting taps

EG-M

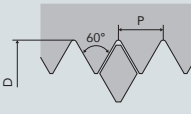

**ISO Metric coarse thread
DIN 8140 Part 2**

D	Drill size* [mm]
EG-M 3	3,15
4	4,2
5	5,25
6	6,3
8	8,4
10	10,5
12	12,5
14	14,5
16	16,5

8-UN

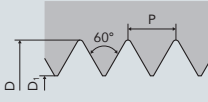

**8-UN thread
ASME B1.1**

D	Pitch [TPI]	Maximum core diam. (tol. 3B) D1 [mm]	Drill size* [mm]
1 1/8"	8	25,519	25,4
1 1/4"	8	28,694	28,6
1 3/8"	8	31,869	31,8
1 1/2"	8	35,044	35,0
1 5/8"	8	38,219	38,1
1 3/4"	8	41,394	41,3
1 7/8"	8	44,569	44,5
2"	8	47,744	47,7

UNC

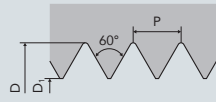

**Unified coarse thread
UNC ASME - B1.1**

D	Pitch [TPI]	Maximum core diam. (tol. 3B) [mm]D1	Drill size* [mm]
Nr. 1	64	1,582	1,55
Nr. 2	56	1,872	1,85
Nr. 3	48	2,146	2,1
Nr. 4	40	2,385	2,35
Nr. 5	40	2,697	2,65
Nr. 6	32	2,896	2,85
Nr. 8	32	3,528	3,5
Nr. 10	24	3,950	3,9
Nr. 12	24	4,590	4,5
1/4"	20	5,250	5,1
5/16"	18	6,680	6,6
3/8"	16	8,082	8
7/16"	14	9,441	9,4
1/2"	13	10,881	10,8
9/16"	12	12,301	12,2
5/8"	11	13,693	13,5
3/4"	10	16,624	16,5
7/8"	9	19,520	19,5
1"	8	22,344	22,25
1 1/8"	7	25,082	25
1 1/4"	7	28,258	28
1 3/8"	6	30,851	30,75
1 1/2"	6	34,026	34
1 3/4"	5	39,560	39,5
2"	4,5	45,367	45

UNF

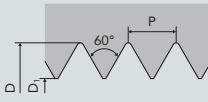

**Unified fine thread
UNF ASME - B1.1**

D	Pitch [TPI]	Maximum core diam. (tol. 3B) [mm]D1	Drill size* [mm]
Nr. 0	80	1,306	1,25
Nr. 1	72	1,613	1,55
Nr. 2	64	1,913	1,85
Nr. 3	56	2,197	2,15
Nr. 4	48	2,459	2,4
Nr. 5	44	2,741	2,7
Nr. 6	40	3,012	2,95
Nr. 8	36	3,597	3,5
Nr. 10	32	4,168	4,1
Nr. 12	28	4,717	4,6
1/4"	28	5,563	5,5
5/16"	24	6,995	6,9
3/8"	24	8,565	8,5
7/16"	20	9,947	9,9
1/2"	20	11,524	11,5
9/16"	18	12,969	12,9
5/8"	18	14,554	14,5
3/4"	16	17,546	17,5
7/8"	14	20,493	20,4
1"	12	23,363	23,25
1 1/8"	12	26,538	26,5
1 1/4"	12	29,713	29,5
1 3/8"	12	32,888	32,75
1 1/2"	12	36,063	36

(*) Drill size according to DIN 336

Drill size cutting taps

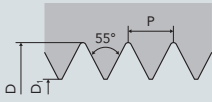
 BSW			
Whitworth thread BSW - BS 84			
D	Pitch [TPI]	Maximum core diam. [mm] D1	Drill size [mm]
3/32"	48	1,912	1,9
1/8"	40	2,591	2,55
5/32"	32	3,214	3,2
3/16"	24	3,744	3,7
7/32"	24	4,539	4,5
1/4"	20	5,156	5,1
5/16"	18	6,589	6,5
3/8"	16	7,988	7,9
7/16"	14	9,332	9,25
1/2"	12	10,589	10,5
9/16"	12	12,177	12
5/8"	11	13,559	13,5
3/4"	10	16,485	16,4
7/8"	9	19,355	19,25
1"	8	22,149	22
1 1/8"	7	24,831	24,75
1 1/4"	7	28,006	27,75
1 3/8"	6	30,528	30,3
1 1/2"	6	33,703	33,5
1 5/8"	5	35,961	35,5
1 3/4"	5	39,136	39
1 7/8"	4,5	41,702	41,5
2"	4,5	44,877	44,5
2 1/4"	4	50,465	50
2 1/2"	4	56,815	56,3
2 3/4"	3,5	62,182	61,5
3"	3,5	68,532	68

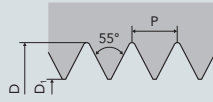
 G			
Whitworth pipe thread EN - ISO 228			
D	Pitch [TPI]	Maximum core diam. [mm] D1	Drill size* [mm]
G 1/8"	28	8,848	8,8
1/4"	19	11,890	11,8
3/8"	19	15,395	15,25
1/2"	14	19,172	19
5/8"	14	21,128	21
3/4"	14	24,658	24,5
7/8"	14	28,418	28,25
1"	11	30,931	30,75
1 1/8"	11	35,579	35,5
1 1/4"	11	39,592	39,5
1 3/8"	11	42,005	41,9
1 1/2"	11	45,485	45,25
1 3/4"	11	51,428	51
2"	11	57,296	57
2 1/4"	11	63,392	63,3
2 3/8"	11	67,080	67
2 1/2"	11	72,866	72,8
2 3/4"	11	79,216	79,1
3"	11	85,566	85,5
3 1/4"	11	91,662	91,5
3 1/2"	11	98,012	98
3 3/4"	11	104,362	104
4"	11	110,712	110,5

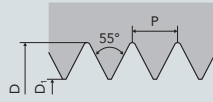
 Rp (BSPP)			
Rp thread (BSPP) DIN EN 10226-1			
D	Pitch [TPI]	Maximum core diam. [mm] D1	Drill size* [mm]
1/8"	28	8,637	8,6
1/4"	19	11,549	11,5
3/8"	19	15,054	15,0
1/2"	14	18,773	18,5
3/4"	14	24,259	24,0

(*) Prefori secondo DIN 336

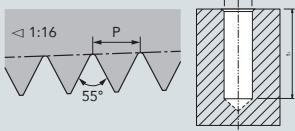
 Rc (BSPT)			
Conical gas thread Rc (BSPT) - DIN EN 10226-2			
D	Pitch [TPI]	Drill size** [mm] D1	t1 [mm]
1/16"	28	6,2	11,9
1/8"	28	8,2	11,9
1/4"	19	11	17,7
3/8"	19	14,5	18,1
1/2"	14	18	24
3/4"	14	23,5	25,3
1"	11	29,5	30,6
1 1/4"	11	38	32,9
1 1/2"	11	44	32,9
2"	11	55,5	37,2

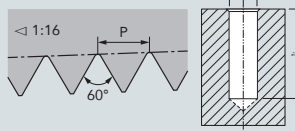
 NPT			
National pipe thread NPT - ANSI B1.20.1			
D	Pitch [TPI]	Drill size** [mm] D1	t1 [mm]
1/16"	27	6,15	12
1/8"	27	8,5	12
1/4"	18	11	17,5
3/8"	18	14,5	17,6
1/2"	14	17,85	22,9
3/4"	14	23,2	23
1"	11,5	29	27,4
1 1/4"	11,5	37,8	28,1
1 1/2"	11,5	44	28,4
2"	11,5	56	28,4

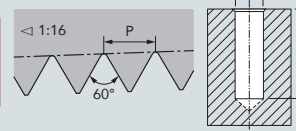
 NPTF			
Dryseal national pipe thread NPTF - ANSI B1.20.3			
D	Pitch [TPI]	Drill size** [mm] D1	t1 [mm]
1/16"	27	6,15	12
1/8"	27	8,5	12
1/4"	18	11	17,5
3/8"	18	14,5	17,6
1/2"	14	17,8	22,9
3/4"	14	23	23
1"	11,5	29	27,4
1 1/4"	11,5	37,8	28,1
1 1/2"	11,5	43,8	28,4
2"	11,5	56	28,4

** For conical threads tapered drill holes are preferable.
Please request specific tables.

Drill size forming taps

ISO Metric coarse thread DIN 13		
D	Pitch [mm]	Drill size [mm]
M 2	0,4	1,85 ± 0,03
2,5	0,45	2,30 ± 0,03
3	0,5	2,80 ± 0,03
3,5	0,6	3,25 ± 0,03
4	0,7	3,70 ± 0,03
5	0,8	4,65 ± 0,03
6	1	5,55 ± 0,05
8	1,25	7,40 ± 0,05
10	1,5	9,30 ± 0,05
12	1,75	11,20 ± 0,05
14	2	13,10 ± 0,05
16	2	15,10 ± 0,05
18	2,5	16,90 ± 0,05
20	2,5	18,90 ± 0,05
24	3	22,70 ± 0,05
27	3	25,70 ± 0,05
30	3,5	28,45 ± 0,05

ISO Metric fine thread DIN 13		
D	Pitch [mm]	Drill size [mm]
M 3	0,35	2,85 ± 0,03
4	0,5	3,80 ± 0,03
5	0,5	4,80 ± 0,03
6	0,75	5,65 ± 0,03
8	1	7,55 ± 0,05
10	1	9,55 ± 0,05
10	1,25	9,40 ± 0,05
12	1	11,55 ± 0,05
12	1,25	11,40 ± 0,05
12	1,5	11,30 ± 0,05
14	1,25	13,40 ± 0,05
14	1,5	13,30 ± 0,05
16	1,5	15,30 ± 0,05
18	1,5	17,30 ± 0,05
20	1,5	19,30 ± 0,05

Whitworth Gas Whitworth EN - ISO 228		
D	Pitch [TPI]	Drill size [mm]
G 1/8"	28	9,25 ± 0,05
1/4"	19	12,50 ± 0,05
3/8"	19	16,00 ± 0,05
1/2"	14	20,00 ± 0,05
3/4"	14	25,50 ± 0,05
1"	11	32,00 ± 0,05

Unified coarse thread UNC ASME - B1.1		
D	Pitch [TPI]	Drill size [mm]
Nr. 8	32	3,80 ± 0,03
Nr. 10	24	4,35 ± 0,03
Nr. 12	24	5,00 ± 0,03
1/4"	20	5,80 ± 0,03
5/16"	18	7,30 ± 0,05
3/8"	16	8,80 ± 0,05
7/16"	14	10,30 ± 0,05
1/2"	13	11,80 ± 0,05
5/8"	11	14,85 ± 0,05
3/4"	10	17,90 ± 0,05

Unified fine thread UNF ASME - B1.1		
D	Pitch [TPI]	Drill size [mm]
Nr. 8	36	3,85 ± 0,03
Nr. 10	32	4,45 ± 0,03
Nr. 12	28	5,10 ± 0,03
1/4"	28	5,95 ± 0,03
5/16"	24	7,45 ± 0,05
3/8"	24	9,05 ± 0,05
7/16"	20	10,55 ± 0,05
1/2"	20	12,15 ± 0,05
5/8"	18	15,25 ± 0,05
3/4"	16	18,35 ± 0,05

Other drill sizes = theoretical flank diameter + pitch/5

In order to obtain the requested tolerance, the formation of a complete internal thread and guarantee the tap tool life, it is important to respect the drill hole diameters and their tight tolerances.

The core diameter of the internal thread obtained by forming is not only a function of the drill hole diameter but also depends on the workpiece material properties. For this reason the tolerance on the core diameter is 7H compared to 6H for cutting taps. For more detailed information see the DIN 13-50 standard.

Tap tolerance

CUTTING TAP TOLERANCE RANGE

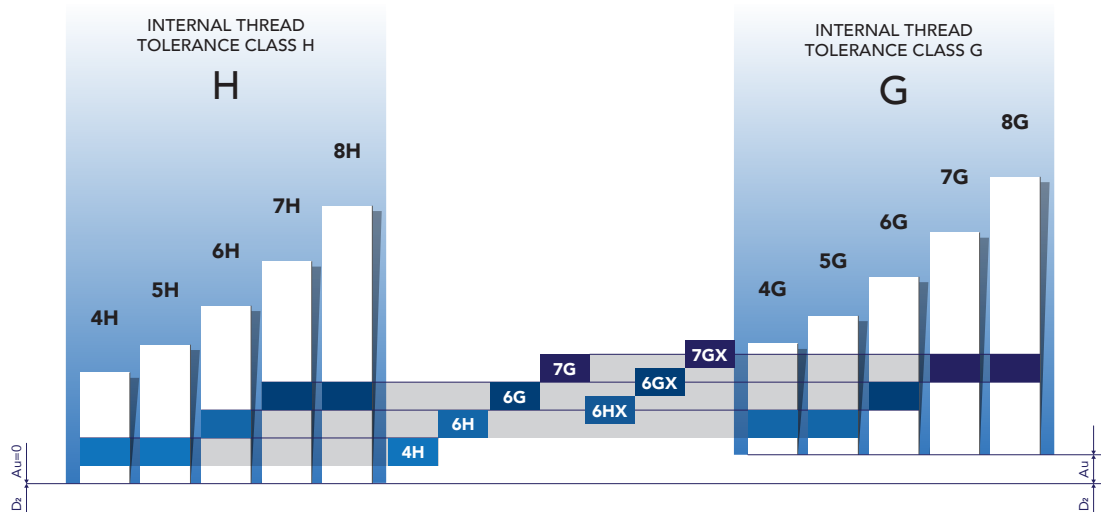

FORMING TAP TOLERANCE RANGE

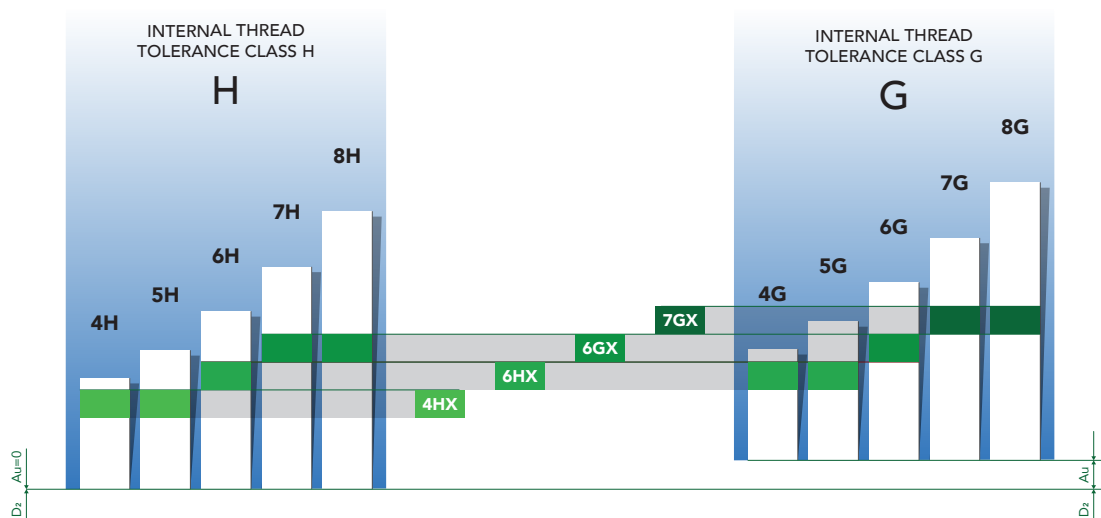

Standard fit for a thread corresponds to tolerance class ISO 2/6H. For more precise fits, without allowance on thread flank, tolerance class ISO 1/4H must be chosen. ISO 3/6G is used in case of loose fits, with large allowance, which is often required for subsequent coatings.

Between classes 6H and 6G, as well as between classes 6G and 7G, tap manufacturers produce taps with tolerance 6HX and 6GX. These taps are used for tapping abrasive materials, such as cast iron or Al-Si alloys, in order to increase their tool life. Another important application is on forming taps, which create the thread by plastic deformation and not by cutting. In this case, due to the elastic return of the material, in order to obtain a thread 6H tolerance, a 6HX tap must be used.

The tolerances described above are collected in the European standard EN 22857.

Tolerance table

Nominal diameter (mm)		Pitch (mm)	Limits on pitch diameter (µm)*			
			Class			
>	≤		4H (ISO1)	6H (ISO2)	6G (ISO3)	7G
0,99	1,4	0,2	+15	-	-	-
			+5	-	-	-
		0,25	+17	-	-	-
1,4	2,8	0,3	+6	-	-	-
			+18	+30	-	-
		0,35	+6	+18	-	-
1,4	2,8	0,2	+16	-	-	-
			+5	-	-	-
		0,25	+18	-	-	-
		0,35	+6	-	-	-
			+20	+34	-	-
0,4	+7	+20	-	-		
2,8	5,6	0,6	+21	+36	-	-
			+7	+21	-	-
		0,45	+23	+38	-	-
		0,7	+8	+23	-	-
			+21	+36	-	-
0,75	+7	+21	-	-		
2,8	5,6	0,35	+21	+36	-	-
			+7	+21	-	-
		0,5	+24	+40	+56	+70
			+8	+24	+40	+55
		0,6	+27	+45	+63	+81
			+9	+27	+45	+63
		0,7	+29	+48	+67	+86
+10	+29		+48	+67		
5,6	11,2	0,75	+29	+48	+67	+86
			+10	+29	+48	+67
		0,8	+30	+50	+70	+90
			+10	+30	+50	+70
		0,75	+32	+53	+74	-
11,2	22,4	1	+11	+32	+53	-
			+35	+59	+83	+107
		1,25	+12	+35	+59	+83
			+38	+63	+88	+113
		1,5	+13	+38	+63	+88
11,2	22,4	1,25	+42	+70	+98	+126
			+14	+42	+70	+98
		1,5	+38	+63	+88	+113
			+13	+38	+63	+88
		1,75	+42	+70	+98	+126
			+14	+42	+70	+98
		2	+45	+75	+105	+135
22,4	45	1	+15	+45	+75	+105
			+48	+80	+112	+144
		1,5	+16	+48	+80	+112
			+54	+90	+126	+162
		2	+18	+54	+90	+126
			+40	+66	+92	+118
		3	+13	+40	+66	+92
+48	+80		+112	+144		
45	90	1,5	+16	+48	+80	+112
			+54	+90	+126	+162
		2	+18	+54	+90	+126
			+64	+106	+148	+190
		3,5	+21	+64	+106	+148
			+67	+112	+157	+202
		4	+22	+67	+112	+157
+71	+118		+165	+212		
5,5	90	4,5	+24	+71	+118	+165
			+75	+125	+175	+225
		5	+25	+75	+125	+175
			+80	+133	+186	+239
		6	+27	+80	+133	+186
90	180	1,5	+84	+140	+196	+252
			+28	+84	+140	+196
		2	+90	+150	+210	+270
			+30	+90	+150	+210

(*) According to EN 22857



Icon description

TAP AND DIE GEOMETRY



Hand tap



Tap with straight flutes



Tap with straight flutes and spiral point



Tap with straight flutes with interrupted thread



Tap with straight flutes and spiral point with interrupted thread



R15 Tap with 15° right hand spiral



L15 Tap with 15° left hand spiral



R40 Z2 Tap with 40° right hand spiral and 2 flutes



R40 Tap with 40° right hand spiral



L40 Tap with 40° right hand spiral Left hand cut



R45 Tap with 45° right hand spiral



Forming tap without oil grooves



Forming tap with oil grooves



Through coolant tap with internal axial hole, for blind holes



Through coolant tap with internal axial and radial holes, for through holes



Through coolant tap with internal axial hole, for blind holes



Through coolant forming tap with internal axial hole, for blind holes



Through coolant forming tap with internal axial and radial holes, for through holes



Thread Mills with internal axial coolant



Thread Mills with internal radial coolant



Die



Back tapering



Tap with through shank



Tap with long shank

HOLE TYPE AND DEPTH



Through



1xD Through, up to 1 x d₁



1,5xD Through, up to 1,5 x d₁



2,5xD Through, up to 2,5 x d₁



3xD Through, up to 3 x d₁



Blind



1,5xD Blind, up to 1,5 x d₁



2xD Blind, up to 2 x d₁



2,5xD Blind, up to 2,5 x d₁



3xD Blind, up to 3 x d₁



Blind and through



1,5xD Blind and through, up to 1,5 x d₁



2xD Blind and through, up to 2 x d₁



2,5xD Blind and through, up to 2,5 x d₁



3xD Blind and through, up to 3 x d₁



Tapered hole



Icon description



Nut

DIRECTION OF CUT



Right hand cut



Left hand cut

TYPE OF CHIP



Short chipping



Medium chipping



Medium to long chipping



Long chipping



Plastic deformation without chip formation

COLOURED RING



Red ring - Hand taps A100 series

TAP AND DIE TOLERANCE



Tolerance 4H / ISO1



Tolerance 6H / ISO2



Tolerance 6G / ISO3



Tolerance 7G



Tolerance 6HX



Tolerance 6GX



Tolerance 7GX



Tolerance 6H + 0,1 mm



Modified 6H Tolerance



Tolerance 3B



Tolerance 2B



Tolerance 2BX



Tolerance ISO 5969



Tolerance ISO 5969X



Medium Tolerance



Tolerance ISO 6g



Tolerance 2A



Tolerance Class A

MATERIAL



Material: solid carbide



Material: conventional high speed steel



Material: conventional high speed steel



Material: powder metallurgy high speed steel



Material: high performance powder metallurgy high speed steel



Material: high performance powder metallurgy high speed steel

THREAD TYPE



ISO Metric coarse thread



ISO Metric fine thread



Unified coarse thread
UNC ASME - B1.1



Icon description

- UNF** Unified fine thread - UNF ASME B1.1
- 8-UN** 8-UN thread - ASME B1.1
- G** Whitworth pipe thread - EN ISO 228
- Rp (BSPP)** Rp thread (BSPP) - DIN EN 10226-1
- Rc (BSPT)** Conical gas thread Rc (BSPT) taper 1:16 - BS 21 and DIN EN 10226-2
- BSW** Whitworth thread - BS 84
- NPT** National pipe thread, taper 1:16 - ASME/ANSI B1.20.1
- NPTF** Dryseal National pipe thread, taper 1:16 - ASME/ANSI B1.20.3
- EG-M** ISO Metric coarse thread - DIN 8140-2
- ISO** ISO thread DIN 13
- UN** American Unified Thread ASME B1.1
- GAS** GAS thread EN ISO 228

CHAMFER FORM

- A (5-6)** Chamfer form A: 5 - 6 threads for through holes
- B (4-5)** Chamfer form B: 4 - 5 threads for through holes
- C (2-3)** Chamfer form C: 2 - 3 threads for blind and through holes
- D (4-5)** Chamfer form D: 4 - 5 threads for through holes
- E (1,5-2)** Chamfer form E: 1,5 - 2 threads for blind holes
- 1,75xP** Die chamfer form: 1,75 x P

APPLICATION INFORMATION

- Tap only for rigid tapping attachment (synchronous)
- High recommended cutting speed
- High tool life

THREAD MILLS

- INT** For internal threads
- EXT** For external threads

Graphic design by:
StudioAlmayern
Chieri - Torino - Italy

Printed by:
IlTipografo
Riva presso Chieri - Torino - Italy
Printed 08/2025

Printed on 100% recycled FSC®
certified coated paper



Changes or printing errors regarding technical details do not justify any claims.
We reserve the right to introduce changes regarding technical details, without prior notice.
Complete or partial reproduction of this catalogue is not permitted without our prior permission.

Tool code list

A SERIES

TOOL CODE	Thread	Page
A1	M	34
A1 LH	M	36
A2	MF	78
A2 LH	MF	81
A4	BSW	129
A5	G	119
A6	Rc(BSPT)	128
A6 B	NPT	132
A6 BZ	NPT	133
A6 F	NPTF	134
A6 FZ	NPTF	135
A7	UNC	101
A8	UNF	109
A9	M	73
A10	MF	98
A15 AZ	M	52
A15 AZ TiH1	M	52
A15 L	M	53
A15 L TiN	M	53
A15 S	M	45
A15 S VAP	M	45
A15 S TiN	M	45
A15 S TiCN	M	45
A15 S 4H	M	47
A15 S 4H TiN	M	47
A15 S 6G	M	48
A15 S 6G TiN	M	48
A15 S 7G	M	49
A15 S 7G TiN	M	49
A15 S LH	M	50
A15 S LH TiN	M	50
A16 S	M	51
A16 S TiN	M	51
A17 S	MF	86
A17 S VAP	MF	86
A17 S TiN	MF	86
A17 S TiCN	MF	86
A17 S TiX2	MF	89
A17 S 6G	MF	90
A17 S 6G TiN	MF	90
A18 S	G	122
A18 S VAP	G	122
A18 S TiCN	G	122
A18 S TiX2	G	122
A19 S	UNC	104
A19 S TiN	UNC	104
A19 S TiCN	UNC	104
A19 S 3B	UNC	104
A19 S TiX2	UNC	105
A20 S	UNF	112
A20 S TiN	UNF	112
A20 S TiCN	UNF	112
A20 S 3B	UNF	112
A20 S TiX2	UNF	113
A21 FC	M	38
A21 FC TiN	M	38
A22 FC	M	40
A22 FC TiN	M	40
A23 FC	MF	82
A23 FC TiN	MF	82
A23 FC LH	MF	82
A24 FC	BSW	130
A24 FP	BSW	130
A26 FC	G	120
A26 FP	G	120
A27 FC	UNC	102
A27 FC TiN	UNC	102
A27 FP	UNC	102

A SERIES

TOOL CODE	Thread	Page
A27 FP TiN	UNC	102
A28 FC	UNF	110
A28 FC TiN	UNF	110
A28 FP	UNF	110
A28 FP TiN	UNF	110
A29	M	55
A29 VAP	M	55
A29 TiN	M	55
A29 6G	M	57
A29 6G TiN	M	57
A29 DIN 376	M	58
A29 DIN 376 TiN	M	58
A29 L	M	59
A29 L TiN	M	59
A30	MF	91
A30 TiN	MF	91
A31	BSW	130
A31 TiN	BSW	130
A32	G	123
A32 TiN	G	123
A33	UNC	106
A33 TiN	UNC	106
A33 3B	UNC	106
A34	UNF	114
A34 TiN	UNF	114
A34 3B	UNF	114
A43 NITR.	M	41
A43 TiCN	M	41
A44 NITR.	M	42
A44 TiCN	M	42
A45 NITR.	MF	85
A45 TiCN	MF	85
A48 NITR.	G	121
A48 TiCN	G	121
A49 NITR.	UNC	103
A49 TiCN	UNC	103
A50 NITR.	UNF	110
A50 TiCN	UNF	110
A59 S	G	124
A59 S VAP	G	124
A59 S TiN	G	124
A59 S TiCN	G	124
A59 S TiX2	G	125
A60 S	UNC	107
A60 S TiN	UNC	107
A60 S TiCN	UNC	107
A60 S TiX2	UNC	107
A61 S	UNF	115
A61 S TiN	UNF	115
A61 S TiCN	UNF	115
A61 S TiX2	UNF	115
A62	M	71
A62 TiH1	M	71
A65	UNC	108
A66	UNF	116
A67	M	43
A67 TiH1	M	43
A70 L	M	68
A70 L TiN	M	68
A70 S	M	60
A70 S VAP	M	60
A70 S TiN	M	60
A70 S TiCN	M	60
A70 S 4H	M	61
A70 S 4H TiN	M	61
A70 S 6G	M	62
A70 S 6G TiN	M	62
A70 S 7G	M	63

A SERIES

TOOL CODE	Thread	Page
A70 S 7G TiN	M	63
A70 SE	M	65
A70 SE TiN	M	65
A70 S LH	M	66
A70 S LH TiN	M	66
A71 S	MF	94
A71 S VAP	MF	94
A71 S TiN	MF	94
A71 S TiCN	MF	94
A71 S TiX2	MF	96
A71 S 6G	MF	97
A71 S 6G TiN	MF	97
A72	M	72
A72 TiH1	M	72
A76 S	M	67
A76 S TiN	M	67
A80 TiN	M	74
A80 6GX TiN	M	74
A80 N TiN	M	75
A80 N 6GX TiN	M	75
A81 TiN	MF	99
A81 6GX TiN	MF	99
A81 N TiN	MF	100
A81 N 6GX TiN	MF	100
A82 N TiN	G	126
A100	M	37
A110 VAP	M	44
A110 CrN	M	44
A119	8-UN	117
A119 TiN	8-UN	117
A120	M	69
A120 VAP	M	69
A120 TiN	M	69
A150 VAP	M	54
A150 TiX2	M	54
A159 S	Rp(BSPP)	127
A159 S TiN	Rp(BSPP)	127
A160	8-UN	118
A160 TiN	8-UN	118
A170 VAP	M	70
A170 TiX2	M	70
A190	EG-M	76
A195	EG-M	77
A195 TiN	EG-M	77
A701 S	M	64
A701 S TiN	M	64

Tool code list

P SERIES		
TOOL CODE	Thread	Page
P15 TiN	M	140
P15 TiH1	M	140
P15 6GX TiH1	M	140
BP15 TiH1	M	140
P17 TiN	MF	159
P17 TiH1	MF	159
P17 6GX TiH1	MF	159
BP17 TiH1	MF	159
P18 TiN	G	177
P18 TiH1	G	177
P19 TiH1	UNC	171
P20 TiH1	UNF	174
P29	M	142
P29 TiN	M	142
P29 TiH1	M	142
BP29 TiH1	M	142
P29 E TiH1	M	143
P30	MF	161
P30 TiN	MF	161
P30 TiH1	MF	161
BP30 TiH1	MF	161
P30 E TiH1	MF	162
P43 V-MAXX	M	138
BP43 V-MAXX	M	138
P43 E V-MAXX	M	138
BP43 E V-MAXX	M	138
P45 V-MAXX	MF	158
BP45 V-MAXX	MF	158
P45 E V-MAXX	MF	158
BP45 E V-MAXX	MF	158
P59 TiN	G	178
P59 TiH1	G	178
BP59 TiH1	G	178
P59 E TiH1	G	179
P60 TiH1	UNC	172
P61 TiH1	UNF	175
P70 TiN	M	144
P70 TiH1	M	144
BP70 TiH1	M	145
P70 6GX TiH1	M	144
P70 7GX TiH1	M	144
P70 E TiN	M	146
P70 E TiH1	M	146
P70 E 6GX TiH1	M	146
P71 TiN	MF	163
P71 TiH1	MF	163
P71 6GX TiH1	MF	163
BP71 TiH1	MF	163
P71 E TiH1	MF	164
P71 E 6GX TiH1	MF	164
P76 L TiH1	M	147
P80 V-MAXX	M	149
P80 6GX V-MAXX	M	149
P80 7GX V-MAXX	M	149
P80 N V-MAXX	M	150
P80 N 6GX V-MAXX	M	150
P80 N 7GX V-MAXX	M	150
P80 E V-MAXX	M	151
P80 NE V-MAXX	M	151
P80 NE 6GX V-MAXX	M	151
BP80 NE V-MAXX	M	152
BP80 N R V-MAXX	M	152
P81 V-MAXX	MF	166
P81 6GX V-MAXX	MF	166
P81 N V-MAXX	MF	167
P81 N 6GX V-MAXX	MF	167
P82 N V-MAXX	G	180

P SERIES		
TOOL CODE	Thread	Page
P130	M	139
P130 V-MAXX	M	139
P150 G-MAXX	M	141
P151 G-MAXX	MF	160
P170 G-MAXX	M	148
BP170 G-MAXX	M	148
P170 E G-MAXX	M	148
P171 G-MAXX	MF	165
P900 N V-MAXX	M	153
P900 N RED-MAXX	M	153
P900 N 6GX RED-MAXX	M	153
P900 N 7GX RED-MAXX	M	153
P900 NE V-MAXX	M	154
P900 NE RED-MAXX	M	154
P900 NE 6GX RED-MAXX	M	154
BP900 N R RED-MAXX	M	155
BP900 N RE RED-MAXX	M	155
BP900 N RED-MAXX	M	155
BP900 NE RED-MAXX	M	155
P900 N L RED-MAXX	M	157
P900 N LH RED-MAXX	M	156
P901 N V-MAXX	MF	168
P901 N RED-MAXX	MF	168
P901 N 6GX RED-MAXX	MF	168
P901 NE V-MAXX	MF	169
P901 NE RED-MAXX	MF	169
P901 NE 6GX	MF	169
BP901 N R RED-MAXX	MF	170
P902 N V-MAXX	G	181
P902 N RED-MAXX	G	181
P902 NE V-MAXX	G	182
P902 NE RED-MAXX	G	182
BP902 N R RED-MAXX	G	183
P903 NE V-MAXX	UNC	173
P903 NE RED-MAXX	UNC	173
P904 NE V-MAXX	UNF	176
P904 NE RED-MAXX	UNF	176

S SERIES		
TOOL CODE	Thread	Page
S15 TiN	M	187
S15 TiH1	M	187
BS15 TiH1	M	187
S17 TiN	MF	191
S43 V-MAXX	M	186
BS43 V-MAXX	M	186
S43 E V-MAXX	M	186
BS43 E V-MAXX	M	186
S45 V-MAXX	MF	190
BS45 V-MAXX	MF	190
S70 TiN	M	188
S70 TiH1	M	188
BS70 TiH1	M	188
S71 TiN	MF	192
S80 N TiN	M	189
S80 N V-MAXX	M	189
S80 N 6GX TiN	M	189
BS80 N R TiN	M	189

H SERIES		
TOOL CODE	Thread	Page
HB29	M	195
HB29 V-MAXX	M	195
HB43	M	194
HB43 V-MAXX	M	194
HB43 E V-MAXX	M	194
HB45	MF	198
HB45 V-MAXX	MF	198
HB45 E V-MAXX	MF	198
HB80 N R V-MAXX	M	197
HB80 N RE V-MAXX	M	197
HB81 N RE V-MAXX	M	199
H130	M	196
H130 V-MAXX	M	196

F SERIES		
TOOL CODE	Thread	Page
X200	M	202
X200 LH	M	202
X201	MF	203
X202	BSW	209
X203	G	208
X204	UNC	206
X205	UNF	207
X206	NPT	210

VR SERIES		
TOOL CODE	Thread	Page
VR10 TiAIN	ISO	215
VR20 TiAIN	ISO	215
VR30 TiAIN	ISO	215
VR40 TiAIN	ISO	216
VR45 TiAIN	ISO	216
VR50 TiAIN	ISO	217
VR55 TiAIN	ISO	217
VR10 TiAIN	UN	218
VR20 TiAIN	UN	218
VR40 TiAIN	UN	219
VR45 TiAIN	UN	219
VR50 TiAIN	UN	220
VR55 TiAIN	UN	220
VR10 TiAIN	G	221
VR20 TiAIN	G	221

VA SERIES	
TOOL CODE	Page
DIN 69893 HSK A	226
DIN 1835 B+E	226
SK DIN 69871 AD	227
SK DIN 69871 AD+B	227
MAS 403 BT	228
MAS 403 BT - B	228
ISO 26623-1	229
Quick-Change Tap Adaptor	230
Extended Quick-Change Tap Adaptor	230
ER Collet	231
Assembly Support	232
Wrench	232



Fratelli Vergnano S.R.L.

Corso Egidio Olia 2,
10023 Chieri - To - Italy
+ 39 011 9423523
info@vergnano.com