

TMG

Thermogrip®-Multigrip

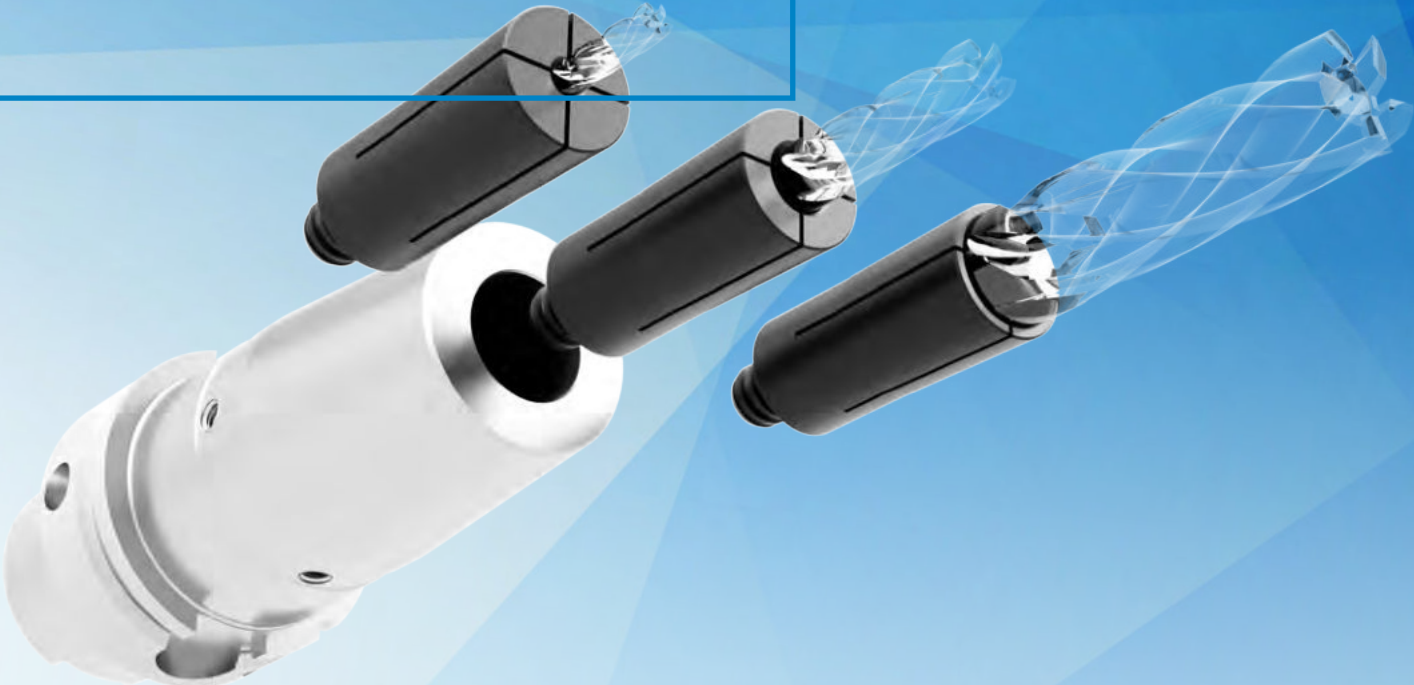

GENERAL
MECHANICAL
ENGINEERING



MEDICAL
DENTAL
TECHNOLOGY

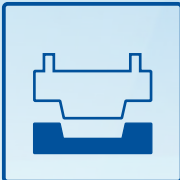

MOLD AND DIE



RENEWABLE
ENERGY



AERONAUTICS AND
AEROSPACE



SHIP- AND PROPEL-
LER CONSTRUCTION

One shrink fit chuck for all diameters

M stands for Constant Maximum Clamping Forces. Due to the consistent maximum overlap of tool and chuck, the design ensures constant high clamping forces. The sleeve is also available with pullout protection (Weldon).

M stands for added value. For the first time, TMG-Multigrip can clamp tool shanks of almost any diameter with one and the same shrink chuck. In this way, the entire production requirement can be covered cost-effectively. The flexibility of basic holders can be used to cover the entire production requirement.



Extreme holding forces - Exceptional flexibility, high rigidity and optimized vibration damping characterize our new TMG-Multigrip.

During the heating process, the assembly is seated using a sleeve pull-back fixture

Sleeve - different versions available
Sleeve and tool are assembled in a cold condition

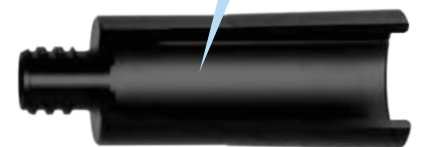
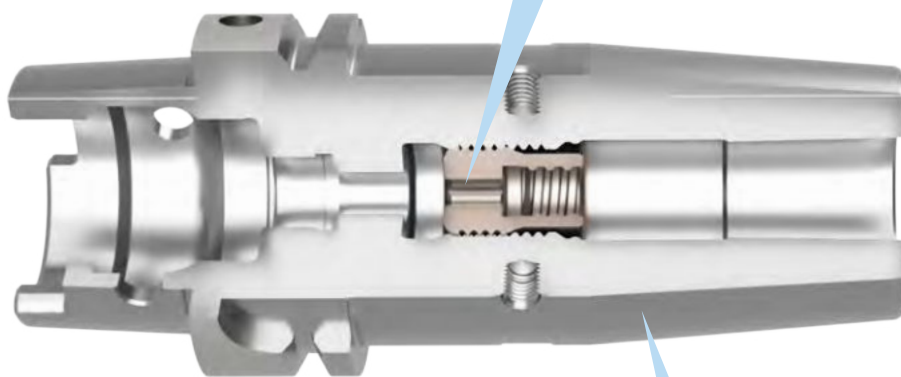

Pinlock System



One basic holder for all diameters
TMG external geometry is identical to that of a T2500-120 Shrink chuck

Features

- Constant maximum clamping forces
- Process-safe clamping of all shank tolerances from h4 to h9
- Anti pullout system for Weldon shanks
- Concentricity $\leq 3 \mu\text{m}^*$

Benefit

- Increase of the metal removal rate
- Excellent damping properties therefore better surfaces and better maintenance of tolerances
- One basic holder for all diameters

*Concentricity of the tool-side taper of the fixture in relation to the machine-side interface.

The new Bilz TMG clamping system combines the strengths of shrink clamping technology with the flexibility of collet solutions. The system consists of basic holders and specially coated collets.

Shank tools (HSS) from 3 to 32 mm can be clamped with previously unattained clamping forces, e.g. more than 950 Nm with $\varnothing 20$ mm tool shank (with automated shrinking with our ISG 3460).

Safe clamping and unclamping is carried out in a fully automatic or also manual process on our induction shrink machines from the ISG3XXX series. Both the shrinking process and the associated chucks are patent pending and only available from us.

Diagram: Transmittable torque with 16 mm shaft diameter

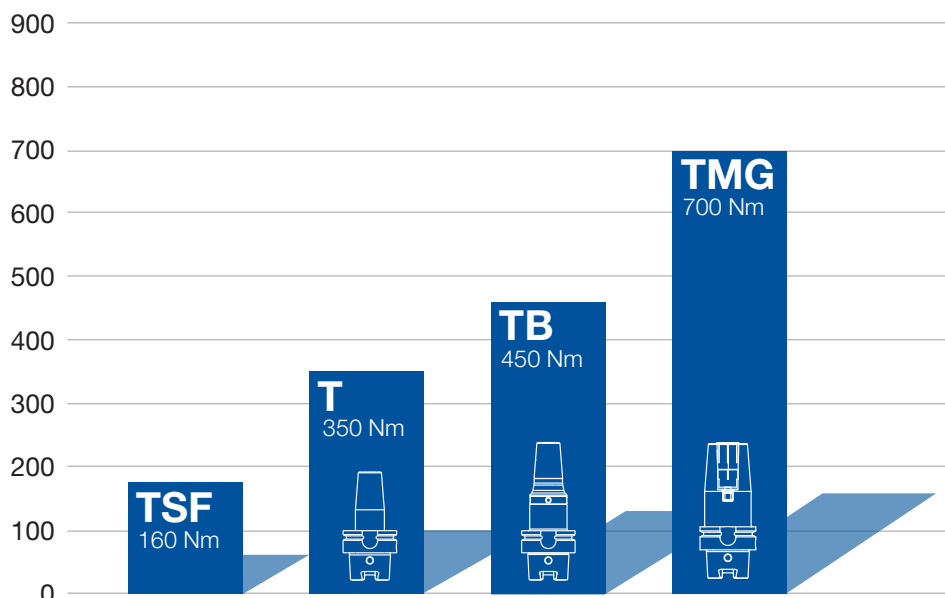

For more information you can find on www.bilz.com

Pinlock mounting



① Insert tool

Unscrew the length stop, align the Weldon clamping surface of the tool so that it is on the side of the hole. Now insert the tool into the clamping sleeve until the Weldon clamping surface is in the area of the hole.

② Insert pin

Insert the locking pin with the help of the tool into the hole as far as it will go. Attention: The pin must not protrude from the clamping sleeve.

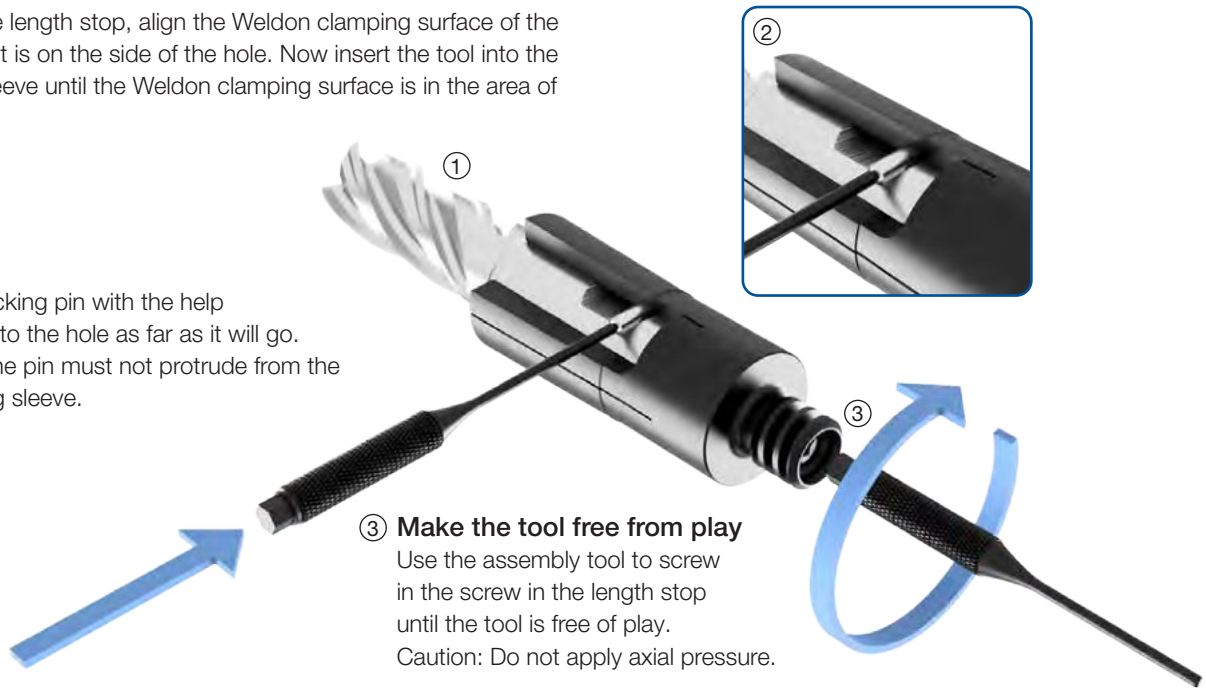

③ Make the tool free from play

Use the assembly tool to screw in the screw in the length stop until the tool is free of play. Caution: Do not apply axial pressure.

Comparison of manual shrinking to automated shrinking on our induction shrink fitter ISG 3460



Manual shrinking

- Place the device in the shrink position of the induction shrink machine.
- Place the tool holder in the tool carrier of the fixture.
- Move the tool holder into the clamping position by turning the drive shaft loosely counterclockwise until the mechanism locks.

- Insert the collet chuck in the tool holder and screw it in by hand until a stronger resistance is felt (approx. 3 turns). Insert the machining tool into the collet.
- Select the appropriate shrinking parameters according to the tool holder and insert the correct ferrite disc.
- Start the shrinking process, whereby the holding time must be activated.
- After the tool holder has been heated, the machining tool is clamped by turning the drive shaft clockwise. The cooling process depends on the respective induction shrink fit machine.

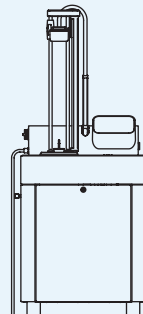

Automatic shrinking

- Place the tool carrier and chuck into the shrink position of the induction shrink machine.
- After selecting the shrinking parameters on our touch display and inserting the correct ferrite disc and coil, the shrinking process can be started by pressing the (Start) button.

- Insert the collet chuck into the tool holder and screw it in by hand until the elastic stop can be felt (approx. 3 turns). The collet chuck only needs to be applied to the axial stop with a low torque. The tool can then be inserted into the collet.
- Pressing the (▶) button continues the shrinking process.
- With the ISG3460-WK, the shrink fit chuck is lowered into the cooling unit and then the coil is lifted to the upper end position. After the cooling time, the chuck is slowly moved upwards and dried with compressed air. It can now be removed by the operator.

ISG 3460



Professional and automated shrinking at a high level, including integrated pneumatic insertion device for ThermoGrip®-Multigrip chuck.

ISG3460WK4-11-WS-BIL	
Ident No.	5193799
Control panel	Touch display
Clamping range SC	Ø 3 – 50 mm
Clamping range HSS	Ø 6 – 50 mm
Coil	quick change system expandable up to Ø 50 mm (1) 4 pole discs
Max. tool length	680 mm at HSK-A63
Max. cooling length	300 mm at HSK-A63
Cooling type	Liquid cooling with drying, geometry independent
Cooling time / Liquid tank	20 s / 50 l
Max. machine interface	HSK-A100, SK 50
Power	11kW
Electric current supply	400 V / 16 A / 50 Hz
Air pressure	4 Bar
Dimensions (W x D x H)	800 x 560 x 1950 mm
Weight	154 kg



Thermogrip®-Multigrip

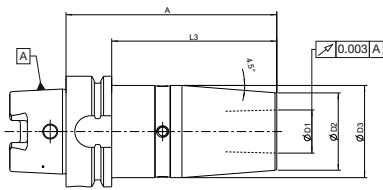

TMG20... HSK-A63, TMG20... HSK-A100



D1	A	L3	D2	D3	Designation	Ident No.
3-20	120	94	44	52,5	TMG20-120-HSKA63	5193624
3-20	120	91	44	53	TMG20-120-HSKA100	5195743

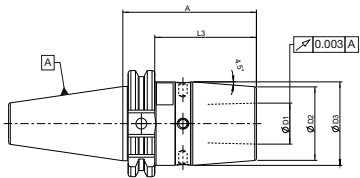

TMG20... AD40, TMG20... AD50



D1	A	L3	D2	D3	Designation	Ident No.
3-20	80	60,9	44	50	TMG20-80-AD40	5198787
3-20	80	60,9	44	50	TMG20-80-AD50	5198789

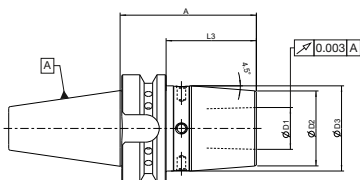

TMG20... FBT40



D1	A	L3	D2	D3	Designation	Ident No.
3-20	80	53	44	50	TMG20-80-FBT40	5191779

Accessories needed

Pole disc		
Designation	Clamping Ø	Ident No.
ISGS3201-TMG20	3,0 – 20 mm	5195237



Thermogrip®-Multigrip

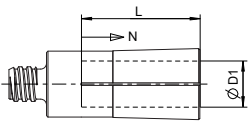

Collets TMG20...			IK	Peripheral	CoolJet
D1	L	N	Ident No.	Ident No.	Ident No.
3	30	15		5195495	
4				5195497	
5				5195498	
6	36	16		5195499	
8	42	10	5195520	5195500	5195508
10			5195521	5195501	5195509
12	48,5	10	5195522	5195502	5195510
14			5195523	5195503	
16	47	10	5195524	5195504	5195511
20			5195525	5195506	

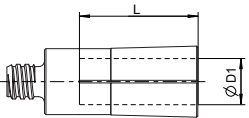

Collets TMG20...		Pinlock IK	Pinlock CoolJet
D1	L	Ident No.	Ident No.
12	43	5195526	5195529
16	45	5195527	5195530
20	47	5195528	5195531

*The Pinlock pins and the insertion tool are included in the scope of delivery

Screw-in fixture (manual)			
Figure	Description	Designation	Ident No.
1	Manual screw-in fixture for WK1, TWK & TLK-Devices	ISGV-WK1	5196754
2	Manual screw-in fixture for WK4-Devices	ISGV-WK4	5194602
3	Torque screwdriver 3,5Nm (Included with screw-in fixtures)	ISGV-TW	
Tool adapter for manual screw-in fixture ISGV-WK or ISGV-TWK-TLK			
4	HSK-A63	T3-WWKB-TMG-HSK63	5194797
	HSK-A100	T3-WWKB-TMG-HSK100	5198397
	AD40, FBT40, CAT40	T3-WWKB-TMG-SK40	5194799
	AD50, FBT50, CAT50	T3-WWKB-TMG-SK50	5200127



WeCare

The subject "Sustainability" targeted by the sister group Leitz, Boehlerit and Bilz



Long-term thinking and sustainable action as a corporate strategy

The global WeCare initiative combines the Group's worldwide activities, some of which have existed for decades, in the areas of society, social affairs and culture, as well as the protection of species, nature and the environment. The WeCare concept places particular emphasis on combining the strengths and commitment of all participating companies and employees in order to achieve the best possible result in terms of sustainability. This means that smaller or local campaigns in particular receive optimum support, as the regional roots are close to the heart of this fourth and fifth generation global family business.

In order to make the momentum of WeCare and the team spirit tangible, the first WeCare campaign weeks were held in 2022 at all locations of the groups worldwide. Through the cooperation of the employees and the financial support of the individual local companies, another positive sign of social responsibility was thus set.

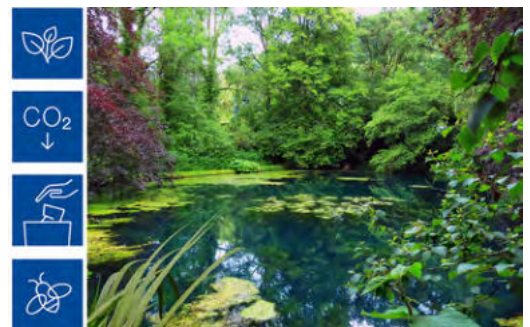

The focus of the WeCare projects:

Social and humanitarian engagement

- Collecting and donating
- Support of social institutions
- Save lives
- Maintenance and signposting of trails

Species, nature and the environmental protection

- Reforestation and creating flower areas
- CO₂-avoidance
- Cleaning the environment and waters
- Giving animals and insects a home